

***Hi-Fi EXPRESS***

# ***FP-740***

## ***Setup Guide***

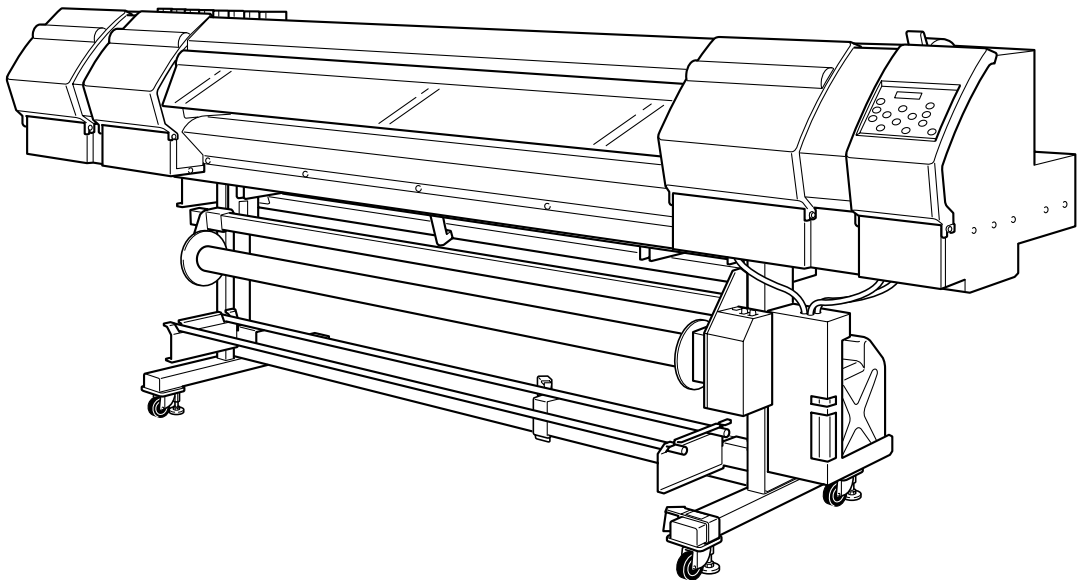

---

### ***Read this first.***



*This describes the setup tasks and important conditions about the installation location that must be met in order to enable use of this machine.*

---

Thank you very much for purchasing this product.

- To ensure correct and safe usage with a full understanding of this product's performance, please be sure to read through this manual completely and store it in a safe location.
- Unauthorized copying or transferral, in whole or in part, of this manual is prohibited.
- The contents of this operation manual and the specifications of this product are subject to change without notice.
- The operation manual and the product have been prepared and tested as much as possible. If you find any misprint or error, please inform us.
- Roland DG Corp. assumes no responsibility for any direct or indirect loss or damage which may occur through use of this product, regardless of any failure to perform on the part of this product.
- Roland DG Corp. assumes no responsibility for any direct or indirect loss or damage which may occur with respect to any article made using this product.

# Table of Contents

 To Ensure Safe Use .....	3
 Pour utiliser en toute sécurité .....	11
<b>Setup Guide</b> .....	<b>19</b>
1. Installation .....	20
Emplacement and Installation Operations .....	20
Deciding On an Installation Site .....	21
Temperature and Humidity .....	22
Installation Space .....	22
2. Included Items .....	23
3. Removing the Packing Materials .....	24
4. Attaching the Included Items and Connecting the Cables .....	26
Installing the Drain Bottle .....	26
Connecting Cables .....	27
5. Installing the Ink Cartridges .....	29
Filling with Ink for the First Time .....	29
Installing the Ink Cartridges .....	29
6. Adjusting the Sensor's Position .....	32
Adjusting the Positioning of the Take-up Unit Sensor .....	32

Company names and product names are trademarks or registered trademarks of their respective holders.

Copyright© 2006 Roland DG Corporation

<http://www.rolanddg.com/>



 ***To Ensure Safe Use***



---





# To Ensure Safe Use

Improper handling or operation of this machine may result in injury or damage to property. Points which must be observed to prevent such injury or damage are described as follows.

## About WARNING and CAUTION Notices

 <b>WARNING</b>	Used for instructions intended to alert the user to the risk of death or severe injury should the unit be used improperly.
 <b>CAUTION</b>	Used for instructions intended to alert the user to the risk of injury or material damage should the unit be used improperly. * Material damage refers to damage or other adverse effects caused with respect to the home and all its furnishings, as well to domestic animals or pets.

## About the Symbols

	The  symbol alerts the user to important instructions or warnings. The specific meaning of the symbol is determined by the design contained within the triangle. The symbol at left means "danger of electrocution."
	The  symbol alerts the user to items that must never be carried out (are forbidden). The specific thing that must not be done is indicated by the design contained within the circle. The symbol at left means the unit must never be disassembled.
	The  symbol alerts the user to things that must be carried out. The specific thing that must be done is indicated by the design contained within the circle. The symbol at left means the power-cord plug must be unplugged from the outlet.

**⚠ Incorrect operation may cause injury**

**⚠ WARNING**



**Keep children away from the machine.**  
The machine includes areas and components that pose a hazard to children and may result in injury, blindness, choking, or other serious accident.



**Never use the machine for any purpose for which it is not intended, or use the machine in an undue manner that exceeds its capacity.**  
Doing so may result in injury or fire.



**For accessories (optional and consumable items, AC adapter, power cord, and the like), use only genuine articles compatible with this machine.**  
Incompatible items may lead to an accident.



**Before attempting cleaning, maintenance, or attachment or detachment of optional items, disconnect the power cord.**  
Attempting such operations while the machine is connected to a power source may result in injury or electrical shock.



**Never attempt to disassemble, repair, or modify the machine.**  
Doing so may result in fire, electrical shock, or injury. Entrust repairs to a trained service technician.

**⚠ CAUTION**



**Exercise caution to avoid being pinched or becoming caught.**  
Inadvertent contact with certain areas may cause the hand or fingers to be pinched or become caught. Use care when performing operations.



**Never attempt operation while wearing a necktie, necklace, or loose clothing. Bind long hair securely.**  
Such items may become caught in the machine, resulting in injury.



**Conduct operations in a clean, brightly lit location.**  
Working in a location that is dark or cluttered may lead to an accident, such as becoming caught in the machine as the result of an inadvertent stumble.



**Never climb or lean on the machine.**  
The machine is not made to support a person. Climbing or leaning on the machine may dislodge components and cause a slip or fall, resulting in injury.



**Be sure to follow the operation procedures described in this documentation. Never allow anyone unfamiliar with the usage or handling of the machine to touch it.**  
Incorrect usage or handling may lead to an accident.

⚠ **Danger of electrical short, shock, electrocution, or fire**

⚠ **WARNING**



**Connect to an electrical outlet that complies with this machine's ratings (for voltage, frequency, and current).** Incorrect voltage or insufficient current may cause fire or electrical shock.

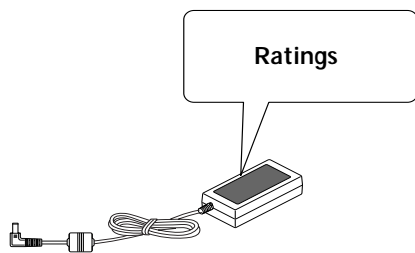
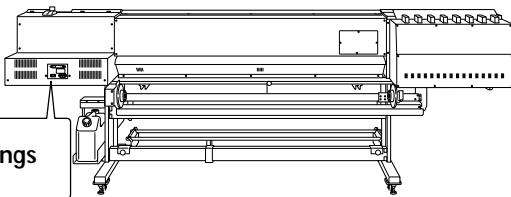

**Never use out of doors or in any location where exposure to water or high humidity may occur. Never touch with wet hands.** Doing so may result in fire or electrical shock.



**Never allow any foreign object to get inside. Never expose to liquid spills.** Inserting objects such as coins or matches or allowing beverages to be spilled into the ventilation ports may result in fire or electrical shock. If anything gets inside, immediately disconnect the power cord and contact your authorized Roland DG Corp. dealer.



**Never place any flammable object nearby. Never use a combustible aerosol spray nearby. Never use in any location where gases can accumulate.** Combustion or explosion may be a danger.



**Handle the power cord, plug, and electrical outlet correctly and with care. Never use any article that is damaged.** Using a damaged article may result in fire or electrical shock.

⚠ **WARNING**



**When using an extension cord or power strip, use one that adequately satisfies the machine's ratings (for voltage, frequency, and current).** Use of multiple electrical loads on a single electrical outlet or of a lengthy extension cord may cause fire.



**Connect to ground.** This can prevent fire or electrical shock due to current leakage in the event of malfunction.



**Position so that the power plug is within immediate reach at all times.** This is to enable quick disconnection of the power plug in the event of an emergency. Install the machine next to an electrical outlet. Also, provide enough empty space to allow immediate access to the electrical outlet.



**If sparking, smoke, burning odor, unusual sound, or abnormal operation occurs, immediately unplug the power cord. Never use if any component is damaged.** Continuing to use the machine may result in fire, electrical shock, or injury. Contact your authorized Roland DG Corp. dealer.



**When the machine will be out of use for a prolonged period, disconnect the power cord.** This can prevent accidents in the event of current leakage or unintended startup.



**⚠ Important notes about the power cord, plug, and electrical outlet**

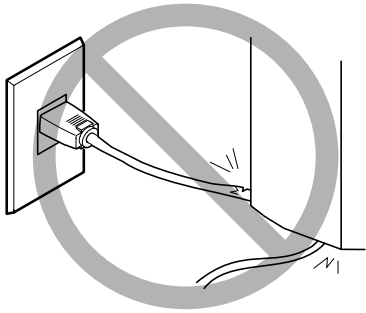

**Never place any object on top or subject to damage.**

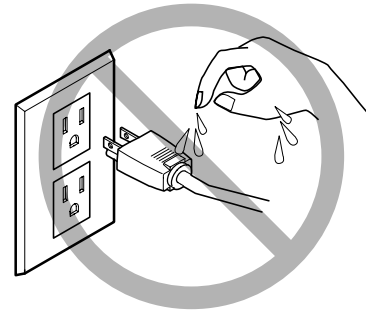

**Never allow to get wet.**

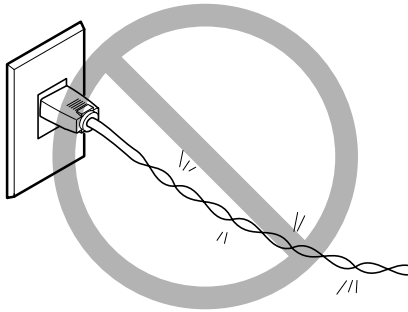

**Never bend or twist with undue force.**

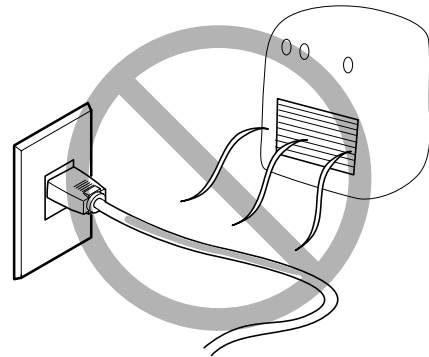

**Never make hot.**

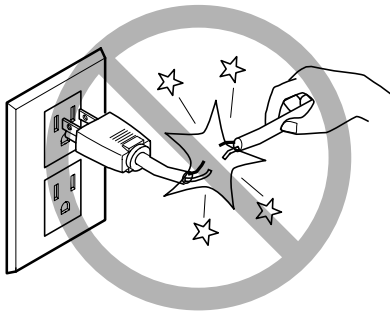

**Never pull with undue force.**

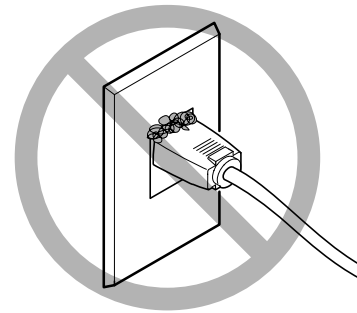

**Dust may cause fire.**

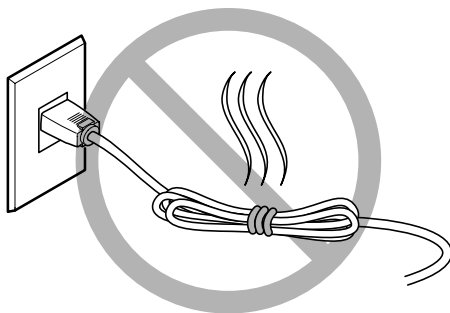

**Never bundle, bind, or roll up.**

 **Ink, cleaning fluid, and discharged fluid are toxic**

 **CAUTION**



**Never drink or sniff ink, cleaning fluid, or discharged fluid, or allow them to come in contact with the eyes or skin.**  
Doing so may be hazardous to the health.



**Never allow an ink cartridge to be subjected to impact, and never attempt to disassemble.**  
Ink may leak.



**Install in a location that can be ventilated.**  
Odor from ink and the like may cause physical distress.

---

 **In the event of ingestion or physical distress**

---

- In the event of contact with the eyes, immediately flush with water for at least 15 minutes. If eye irritation continues, seek treatment by a physician.
- In the event of contact with skin, immediately wash with soap. If irritation or inflammation occur, seek treatment by a physician.
- In the event of ingestion, do not induce vomiting, and immediately seek treatment by a physician. Forcibly inducing vomiting may lead to danger of choking.
- If odor leads to physical distress, move to a well-ventilated location and rest quietly. If dizziness or nausea persists, seek treatment by a physician.

 **This machine weighs 300 kg (662 lb.).**

## **WARNING**

 **Entrust operations such as transportation, unloading, and emplacement to trained workers.**

Handling requires special equipment and training. Performing operations in an unreasonable manner may result in a major accident.

 **Install the machine in a location that is level, stable, and able to bear the weight of the machine.**

The total weight of the machine may reach 300 kg (662 lb.) or more. Installation in an unsuitable location may cause a major accident, including tipover, fall, or collapse.

 **Be sure to anchor the stand to the floor.**  
If the machine should begin to topple, a major accident may result, including crushing of the appendages or the body.

## **CAUTION**

 **Handling roll media is an operation that must be performed by two persons or more, and care must be taken to prevent falls.**

Attempting to lift heavy media in a manner that taxes your strength may cause physical injury.

 **When storing roll media, implement adequate safety measures to ensure that the stored media will not roll, fall, or topple over.**

Danger exists of becoming pinned under the media and suffering serious injury.

## ⚠ Warning Labels

Warning labels are affixed to make areas of danger immediately clear. The meanings of these labels are as follows. Be sure to heed their warnings.

Also, never remove the labels or allow them to become obscured.

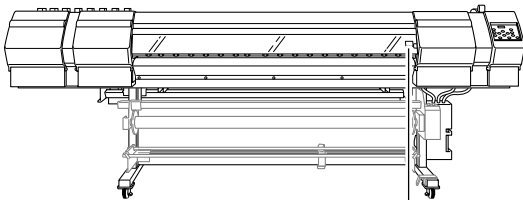

**Caution: Moving Print Heads**

The print heads inside the cover move at high speed and pose a hazard. Never insert the hand or fingers into the gap.

 ***Pour utiliser en  
toute sécurité***



---





# Pour utiliser en toute sécurité

La manipulation ou l'utilisation inadéquates de cet appareil peuvent causer des blessures ou des dommages matériels. Les précautions à prendre pour prévenir les blessures ou les dommages sont décrites ci-dessous.

## Avis sur les avertissements

 <b>ATTENTION</b>	Utilisé pour avertir l'utilisateur d'un risque de décès ou de blessure grave en cas de mauvaise utilisation de l'appareil.
 <b>PRUDENCE</b>	Utilisé pour avertir l'utilisateur d'un risque de blessure ou de dommage matériel en cas de mauvaise utilisation de l'appareil.  * Par dommage matériel, il est entendu dommage ou tout autre effet indésirable sur la maison, tous les meubles et même les animaux domestiques.

## À propos des symboles

	Le symbole $\triangle$ attire l'attention de l'utilisateur sur les instructions importantes ou les avertissements. Le sens précis du symbole est déterminé par le dessin à l'intérieur du triangle. Le symbole à gauche signifie "danger d'électrocution".
	Le symbole $\otimes$ avertit l'utilisateur de ce qu'il ne doit pas faire, ce qui est interdit. La chose spécifique à ne pas faire est indiquée par le dessin à l'intérieur du cercle. Le symbole à gauche signifie que l'appareil ne doit jamais être démonté.
	Le symbole $\bullet$ prévient l'utilisateur sur ce qu'il doit faire. La chose spécifique à faire est indiquée par le dessin à l'intérieur du cercle. Le symbole à gauche signifie que le fil électrique doit être débranché de la prise.

## ⚠ L'utilisation incorrecte peut causer des blessures

### ⚠ ATTENTION



**Garder les enfants loin de l'appareil.**

L'appareil comporte des zones et des composants qui présentent un danger pour les enfants et qui pourraient causer des blessures, la cécité, la suffocation ou d'autres accidents graves.



**Ne jamais utiliser l'appareil à des fins autres que celles pour lesquelles il est conçu. Ne jamais l'utiliser de manière abusive ou d'une manière qui dépasse sa capacité.**

Le non-respect de cette consigne peut causer des blessures ou un incendie.



**Utiliser uniquement des accessoires d'origine (accessoires en option, articles consommables, adaptateur CA, câble d'alimentation et autres articles semblables), compatibles avec l'appareil.**

Les articles incompatibles risquent de causer des accidents.



**Débrancher le câble d'alimentation avant de procéder au nettoyage ou à l'entretien de l'appareil, et avant d'y fixer ou d'en retirer des accessoires en option.**

Tenter ces opérations pendant que l'appareil est branché à une source d'alimentation peut causer des blessures ou un choc électrique.



**Ne jamais tenter de démonter, de réparer ou de modifier l'appareil.**

Le non-respect de cette consigne risque de provoquer un incendie, un choc électrique ou des blessures. Confier les réparations à un technicien ayant la formation requise.

### ⚠ PRUDENCE



**Faire preuve de prudence pour éviter l'écrasement ou le coincement.**

La main ou les doigts peuvent être écrasés ou coincés s'ils entrent en contact avec certaines surfaces par inadvertance. Faire preuve de prudence pendant l'utilisation de l'appareil.



**Ne jamais faire fonctionner l'appareil si on porte une cravate, un collier ou des vêtements amples. Bien attacher les cheveux longs.**

Ces vêtements ou ces objets peuvent être coincés dans l'appareil, ce qui causerait des blessures.



**Utiliser l'appareil dans un endroit propre et bien éclairé.**

Travailler dans un endroit sombre ou encombré peut causer un accident; l'utilisateur risque, par exemple, de trébucher malencontreusement et d'être coincé par une partie de l'appareil.



**Ne jamais grimper ni s'appuyer sur la machine.**

La machine n'est pas conçue pour supporter le poids d'une personne. Grimper ou s'appuyer sur la machine peut déplacer des éléments et causer un faux pas ou une chute, ce qui causerait des blessures.



**S'assurer de suivre les procédures d'utilisation décrites dans la documentation. Ne jamais permettre à quiconque ne connaît pas le fonctionnement ou la manutention de l'appareil de le toucher.**

L'utilisation ou la manutention incorrectes peuvent causer un accident.

## ⚠ Risque de décharge ou de choc électrique, d'électrocution ou d'incendie

### ⚠ ATTENTION



**Brancher à une prise électrique conforme aux caractéristiques de cet appareil (tension, fréquence et courant).**

Une tension incorrecte ou un courant insuffisant peuvent causer un incendie ou un choc électrique.

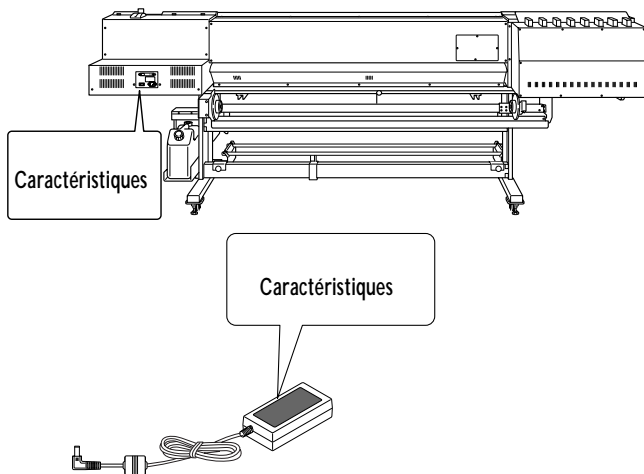

**Ne jamais utiliser à l'extérieur ni à un endroit où l'appareil risque d'être exposé à de l'eau ou à une humidité élevée. Ne jamais toucher l'appareil avec des mains mouillées.**

Le non-respect de cette consigne risque de provoquer un incendie ou un choc électrique.



**Ne jamais insérer d'objet étranger dans l'appareil. Ne jamais exposer l'appareil aux déversements de liquides.**

L'insertion d'objets comme des pièces de monnaie ou des allumettes, ou le déversement de liquides dans les orifices de ventilation peuvent causer un incendie ou un choc électrique. Si un objet ou du liquide s'infiltré dans l'appareil, débrancher immédiatement le câble d'alimentation et communiquer avec le représentant Roland DG Corp. autorisé.



**Ne jamais placer d'objet inflammable à proximité de l'appareil. Ne jamais utiliser de produit inflammable en aérosol à proximité de l'appareil. Ne jamais utiliser l'appareil dans un endroit où des gaz peuvent s'accumuler.**

Une combustion ou une explosion pourraient se produire.

### ⚠ ATTENTION



**Manipuler le câble d'alimentation, la fiche et la prise électrique correctement et avec soin.**

Ne jamais utiliser un article endommagé, car cela pourrait causer un incendie ou un choc électrique.



**Si une rallonge ou une bande d'alimentation électrique sont utilisées, s'assurer qu'elles correspondent aux caractéristiques de l'appareil (tension, fréquence et courant).**

L'utilisation de plusieurs charges électriques sur une prise unique ou une longue rallonge peut causer un incendie.



**Mise à la terre.**

La mise à la terre peut prévenir un incendie ou un choc électrique dus à une fuite de courant en cas de défaillance.



**Placer l'appareil de façon à ce que la fiche soit facile d'accès en tout temps.**

Ainsi, l'appareil pourra être débranché rapidement en cas d'urgence. Installer l'appareil près d'une prise électrique. En outre, prévoir suffisamment d'espace pour que la prise électrique soit facile d'accès.



**S'il se produit des étincelles, de la fumée, une odeur de brûlé, un bruit inhabituel ou un fonctionnement anormal, débrancher immédiatement le câble d'alimentation. Ne jamais utiliser si un composant est endommagé.**

Continuer à utiliser l'appareil peut causer un incendie, un choc électrique ou des blessures. Communiquer avec le représentant Roland DG Corp. Autorisé.



**Si l'appareil doit rester inutilisé pendant une longue période, débrancher le câble d'alimentation.**

Cela peut prévenir les accidents en cas de fuite de courant ou de démarrage accidentel.



**⚠ Remarques importantes à propos du câble d'alimentation, de la fiche et de la prise électrique**

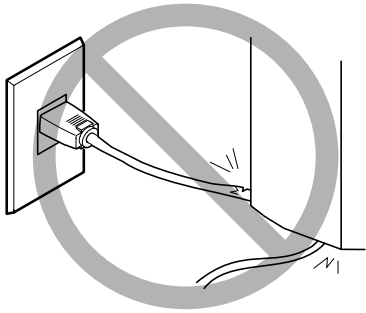

Ne jamais déposer aucun objet sur le câble, sur la fiche ou sur la prise car cela risque de les endommager.

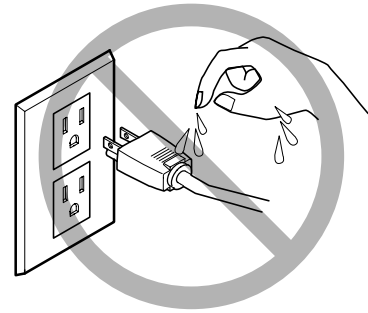

Ne jamais laisser l'eau toucher le câble, la fiche ou la prise.

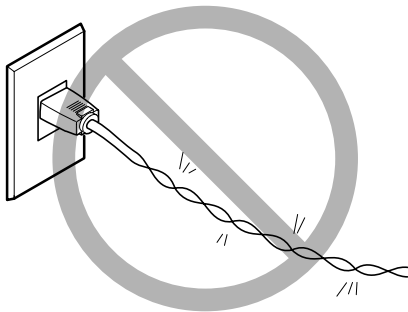

Ne jamais plier ni tordre le câble avec une force excessive.

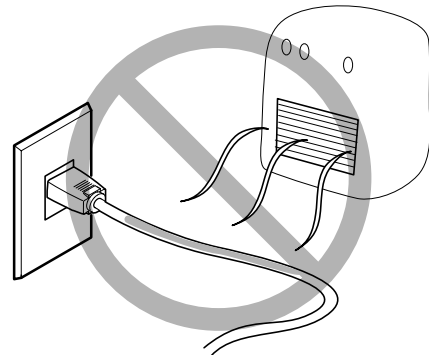

Ne jamais chauffer le câble, la fiche ou la prise.

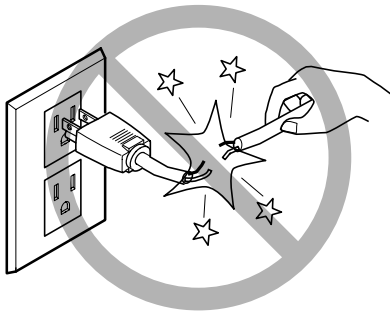

Ne jamais tirer sur le câble ou la fiche avec une force excessive.

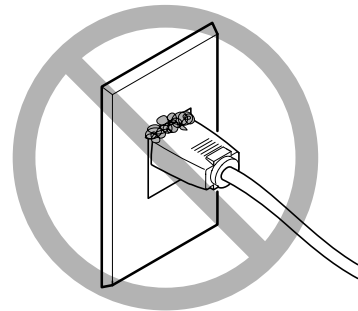

La poussière peut causer un incendie.

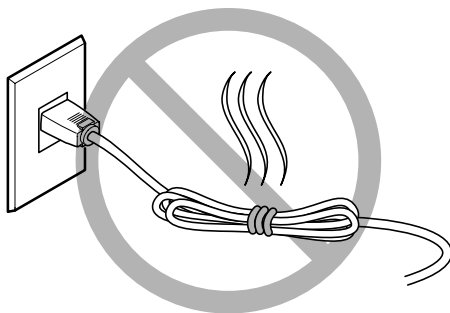

Ne jamais plier ni enrouler le câble.

 **L'encre, les liquides nettoyants et les liquides usés sont toxiques**

 **PRUDENCE**



**Ne jamais boire l'encre, le liquide de nettoyage ni les liquides usés, ne pas en respirer les vapeurs et ne pas laisser les produits entrer en contact avec les yeux ou la peau.**

Cela est dangereux pour la santé.



**Ne jamais soumettre une cartouche d'encre à des chocs. Ne jamais tenter d'ouvrir une cartouche d'encre.**

De l'encre pourrait s'échapper.



**S'assurer que le lieu de travail est bien aéré.**

L'absence d'aération adéquate peut créer une situation dangereuse pour la santé.

---

 **En cas d'ingestion ou de trouble physique**

- En cas de contact avec les yeux : rincer immédiatement et abondamment à l'eau courante pendant au moins 15 minutes. Si les yeux sont toujours irrités, consulter un médecin.
- En cas de contact avec la peau : laver immédiatement à l'eau et au savon. En cas d'irritation ou d'inflammation de la peau : consulter un médecin.
- En cas d'ingestion : ne pas provoquer le vomissement et demander immédiatement l'aide d'un médecin. Provoquer le vomissement peut créer un risque de suffocation.
- Si l'odeur cause un trouble physique, amener la personne dans un endroit bien aéré et la faire se reposer. Si l'étourdissement ou la nausée persistent, consulter un médecin.

 **Le poids de cet appareil est de 300 kg (662 lb.)**

## ATTENTION



**Confier les opérations comme le transport, le déchargement et la mise en place à des travailleurs qui ont reçu la formation requise.**

La manutention exige de la formation et de l'équipement spécialisés. Tenter de procéder à ces opérations de manière intempestive peut provoquer un accident grave.



**Installer l'appareil à un endroit stable et plat et capable de supporter son poids.**

Le poids total de l'appareil peut être d'au moins 300 kg (662 lb.). Installer l'appareil à un endroit inapproprié peut provoquer un accident grave comme le renversement, la chute ou l'écrasement.



**S'assurer d'ancrer la base de l'appareil au sol.**

Si l'appareil devait commencer à basculer, il s'ensuivrait un accident grave, par exemple l'écrasement de membres ou du corps.

## PRUDENCE



**La manutention du support en rouleau doit être faite par deux personnes ou plus et il faut prendre des précautions pour éviter les chutes.**

Tenter de soulever des objets trop lourds peut causer des blessures.



**Prendre les mesures de sécurité adéquates pour l'entreposage des rouleaux de support pour s'assurer qu'ils ne rouleront pas, ne tomberont pas et ne se renverseront pas.**

Il y a risque d'être écrasé par le support et de subir des blessures graves.

## ⚠ Vignettes d'avertissement

Des vignettes d'avertissement sont apposées pour qu'il soit facile de repérer les zones dangereuses. La signification des vignettes est donnée ci-dessous. Respecter les avertissements. Ne jamais retirer les vignettes et ne pas les laisser s'encrasser.

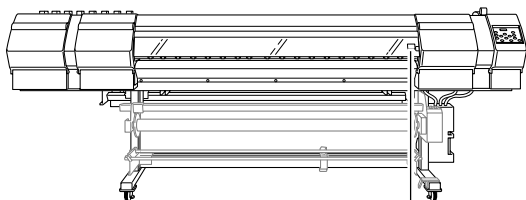

**Attention : Têtes d'impression mobiles**  
Les têtes d'impression sous le couvercle se déplacent à haute vitesse et représentent un danger. Ne jamais insérer la main ou les doigts dans l'ouverture.

# *Setup Guide*

---

# 1. Installation

## Emplacement and Installation Operations

Emplacement and installation of the machine are to be carried out by a service technician.

**⚠ WARNING** Entrust operations such as transportation, unloading, and emplacement to trained workers.

Handling requires special equipment and training. Performing operations in an unreasonable manner may result in a major accident.

**⚠ WARNING** After installation, keep the stand secure in place using the adjusters. If the machine should begin to topple, a major accident may result, including crushing of the appendages or the body.

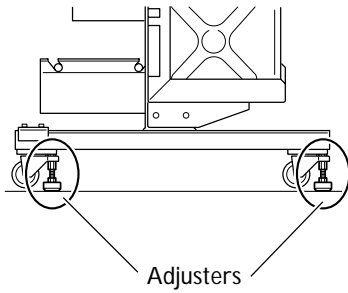

## Deciding On an Installation Site

Install in a quiet, stable location offering good operating conditions. An unsuitable location can cause accident, fire, faulty operation, or breakdown.

- ⚠️ WARNING**    **Install the machine in a location that is level, stable, and able to bear the weight of the machine.**  
 This machine weighs approx. 300 kg. Installation in an unsuitable location may cause a major accident, including tipover, fall, or collapse.
- ⚠️ WARNING**    **Never install in a location exposed to water or to gasoline, thinner, or any other flammable material.**  
 Current leakage may cause electrical shock, electrocution, or combustion and fire.
- ⚠️ WARNING**    **Never place any flammable object nearby. Never use in any location where gases can accumulate.**  
 Combustion or explosion may be a danger.
- ⚠️ WARNING**    **Install in a clean, brightly lit location.**  
 Working in a location that is dark or cluttered can be hazardous. Operations in such locations may cause an accident, such as tripping and becoming pinned under the roll media.
- ⚠️ WARNING**    **Position so that the power plug is within immediate reach at all times.**  
 This is to enable quick disconnection of the power plug in the event of an emergency. Install the machine next to an electrical outlet. Also, provide enough empty space to allow immediate access to the electrical outlet.
- ⚠️ CAUTION**    **Install in a location that can be ventilated.**  
 Odor from ink and the like may cause physical distress.

### Unsuitable Installation Sites

- Locations subject to large fluctuations in temperature or humidity
- Locations subject to shaking or vibration
- Locations where the floor is tilted, not level, or unstable
- Dusty locations
- Locations exposed to direct sunlight or near air-conditioning or heating equipment
- Locations exposed to water or moving air
- Locations exposed to considerable electrical or magnetic noise, or other forms of electromagnetic energy

## Temperature and Humidity

Maintain the specified temperature and humidity even when the machine is not in use. Temperatures that are too high may degrade the ink and cause malfunction. Temperatures that are too low may cause the ink to freeze and damage the heads.

During operation: Temperature 20 to 32°C (68 to 89.6°F), relative humidity 35 to 80% (no condensation)  
During nonoperation: Temperature 5 to 40°C (41 to 104°F), relative humidity 20 to 80% (no condensation)

## Installation Space

The space shown in the figure is required in order to use this machine.

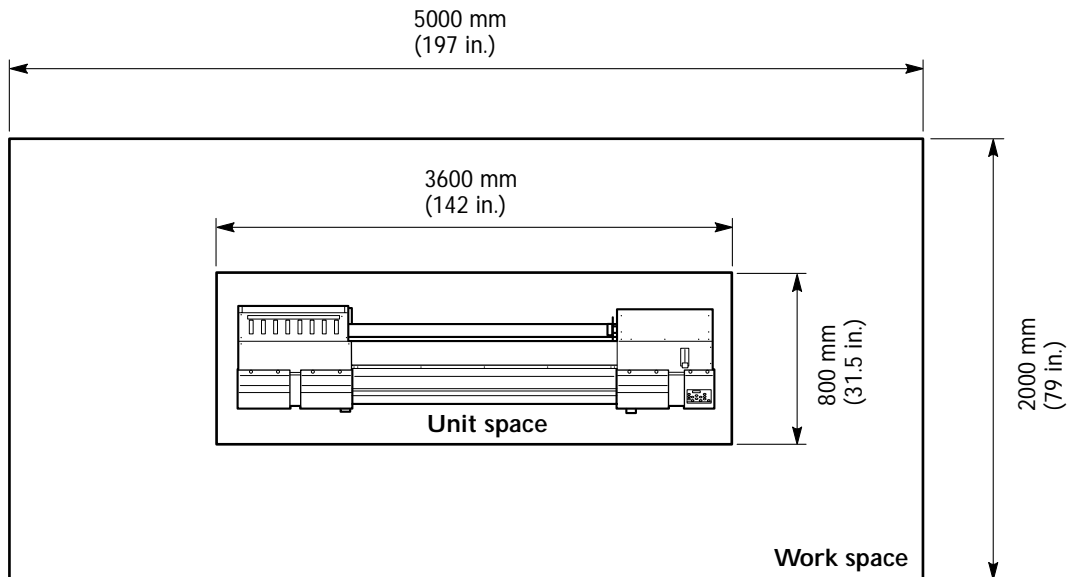



## 2. Included Items

The following items are included with the machine. Make sure they are all present and accounted for.

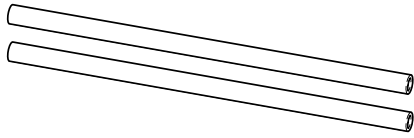

Media reinforcement pipes

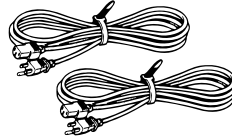

Power cords



AC adapter

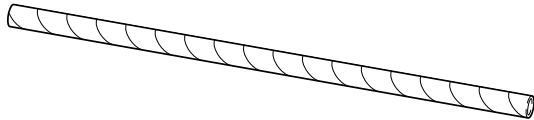

Paper tube

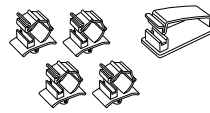

Cable clamps

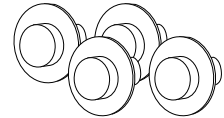

Media flanges



Tracking shafts

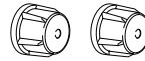

End caps



Stoppers

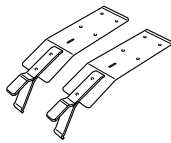

Media clamps

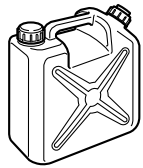

Drain bottle

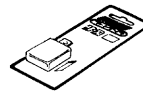

Replacement blade for separating knife

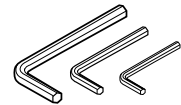

Hexagonal wrenches \*

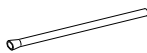

Cap-unit tool

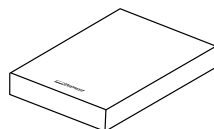

Software RIP set

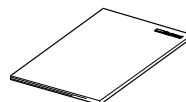

User's Manual

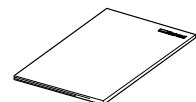

Setup Guide  
(this document)

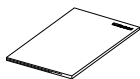

Roland-PrintServer  
Network Setup Guide



Roland-PrintServer  
CD-ROM

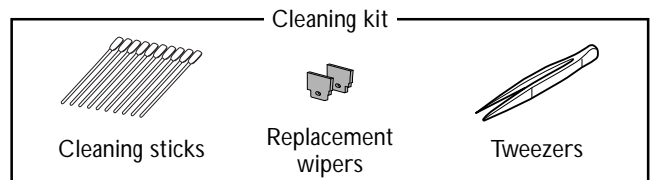

Cleaning kit

Cleaning sticks

Replacement  
wipers

Tweezers

\* These wrenches are used when installing or moving the unit.

# 3. Removing the Packing Materials

Tape and packing materials are attached to the machine to protect it from vibration during transportation. When installation is complete, remove these.

**⚠ CAUTION** Perform this task with all power switches left switched off. Otherwise sudden movement of the machine may cause injury.

- Remove all packing materials. Any that remain may cause faulty operation or breakdown when the power is switched on.
- Store the packing materials carefully, because they are needed again when transporting the machine for relocation or the like.

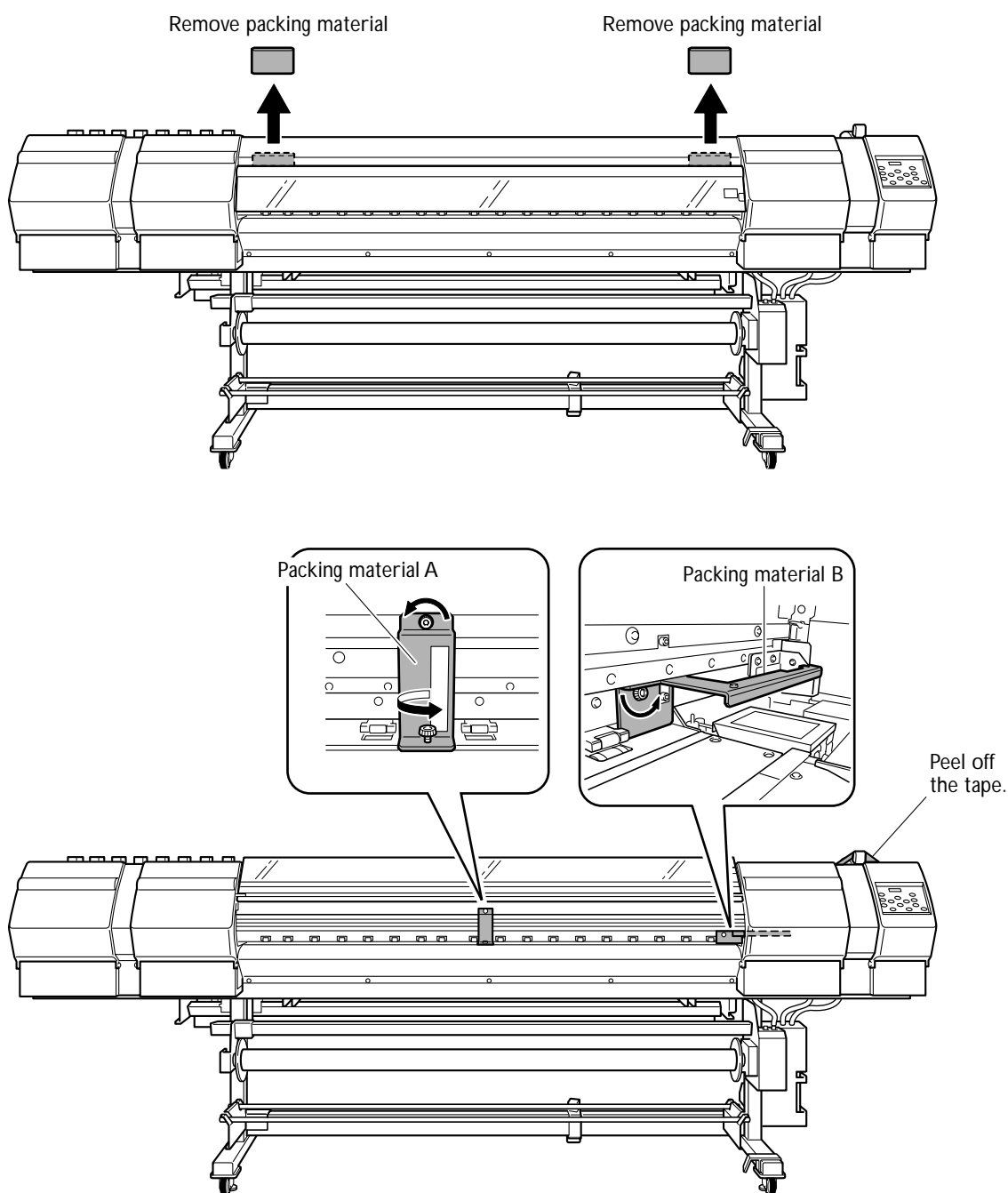

### 3. Removing the Packing Materials

You can attach the removed packing materials at the location shown in the figure for storage.

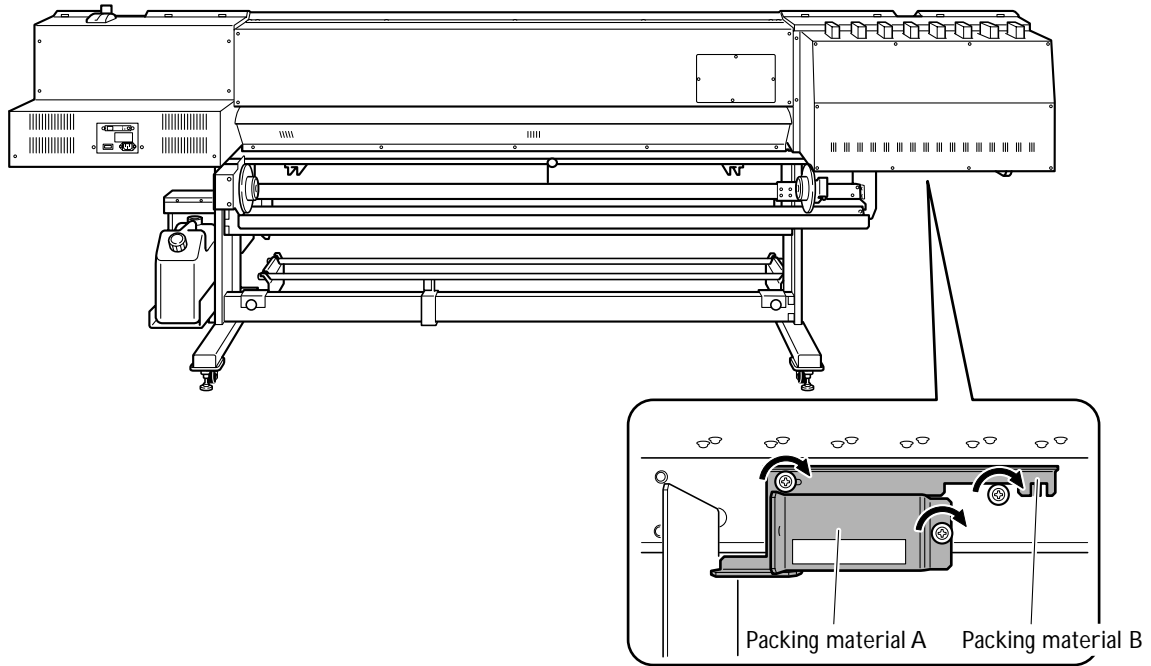

# 4. Attaching the Included Items and Connecting the Cables

## Installing the Drain Bottle

**⚠ CAUTION** Perform this task with all power switches left switched off. Otherwise sudden movement of the machine may cause injury.

### 1. Insert the tube into the bottle stand.

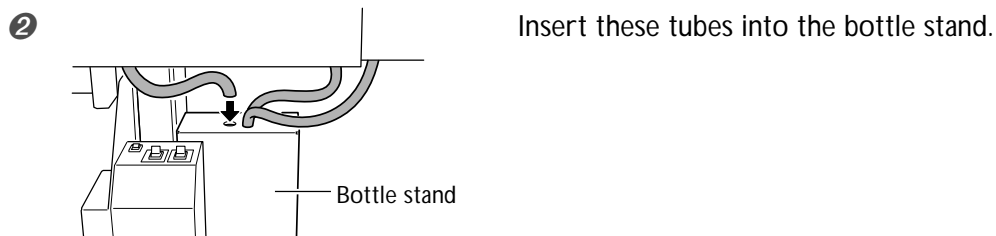
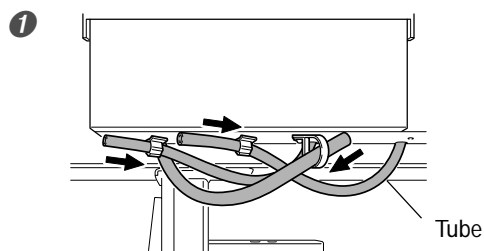

### 2. Remove the lid from the drain bottle.

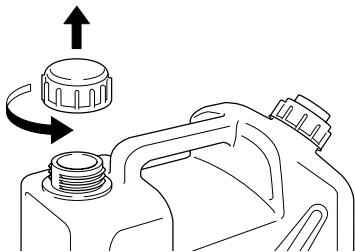

### 3. Insert the drain bottle

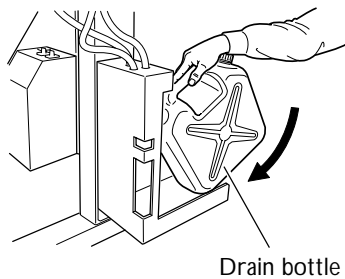

## Connecting Cables

- ⚠ WARNING** Do not use with any electrical power supply that does not meet the ratings displayed on the unit.  
Use with any other power supply may lead to fire or electrocution.
- ⚠ WARNING** Ground the unit with the ground wire.  
Failure to do so may result in risk of electrocution in the event of a mechanical problem.
- ⚠ CAUTION** Perform this task with all power switches left switched off.  
Otherwise sudden movement of the machine may cause injury.

### Connecting the printer cable

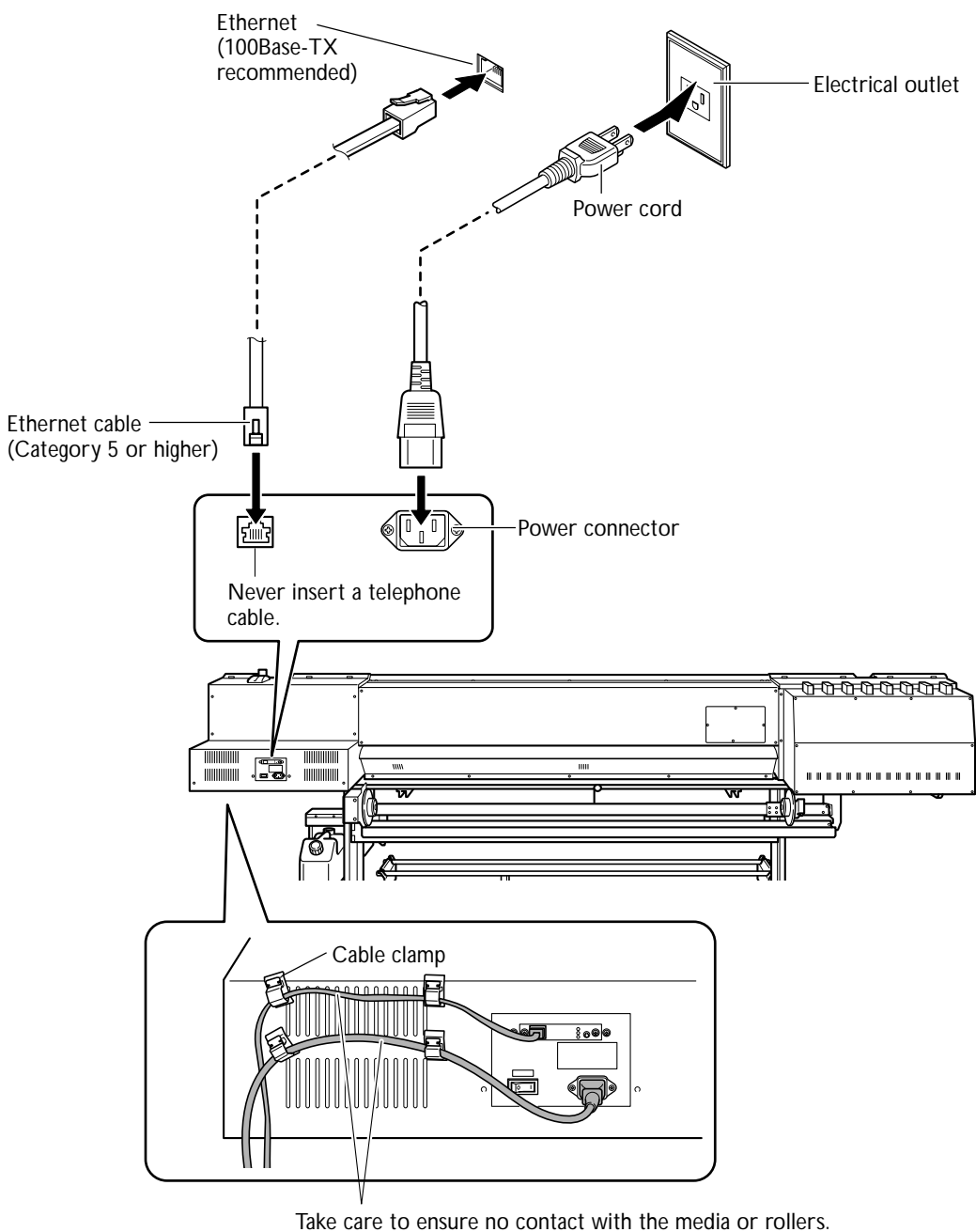

#### 4. Attaching the Included Items and Connecting the Cables

---

##### Connecting the take-up unit cable

---

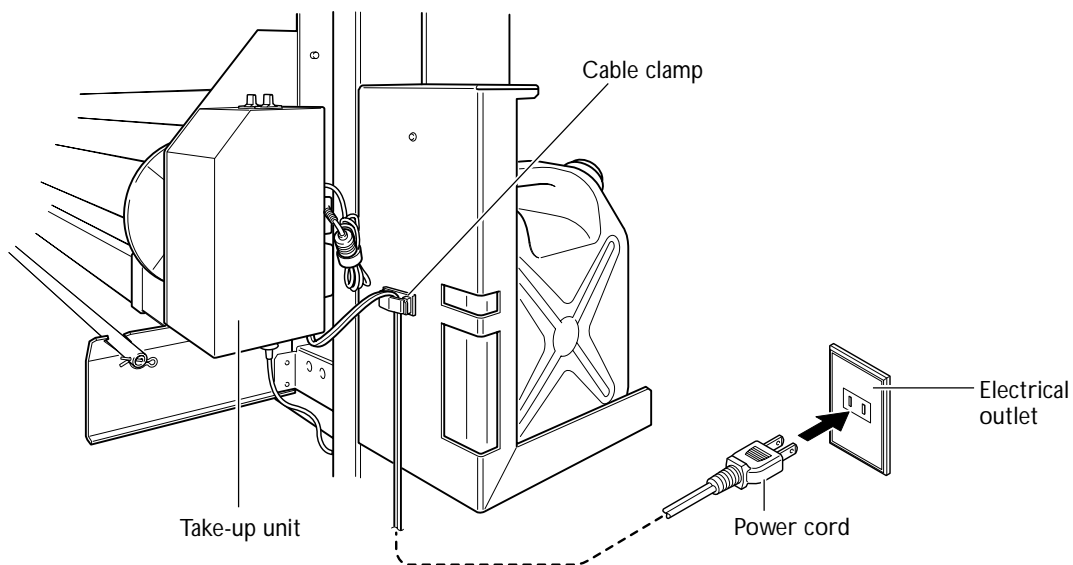

# 5. Installing the Ink Cartridges

## Filling with Ink for the First Time

Special procedures are required when installing ink cartridges for the first time. These are required only once, when installing ink cartridges for the first time after shipment from the factory. Be sure to carry out this operation according to the procedure described below.

Never under any circumstances use anything other than the specified type of ink.

## Installing the Ink Cartridges

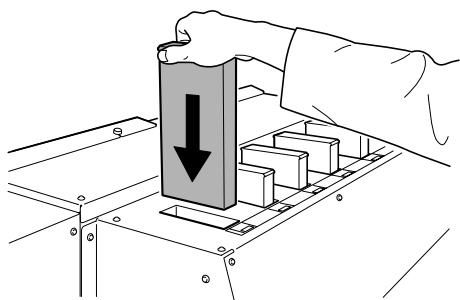

- Keep the labeled side face up.
- Insert and remove slowly, one at a time.
- Insert firmly, as far as it will go.

SET CARTRIDGE  
1 2 3 4 5 6 7 8

Be sure to follow the on-screen instructions for insertion and removal.

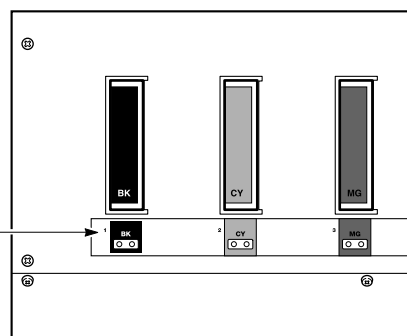

### ⚠ CAUTION

Never insert your hand or fingers into the opening of the front cover. The print heads move at high speed inside the cover. Contact may cause injury.

**1.** Switch on the power and make the initial settings.

1

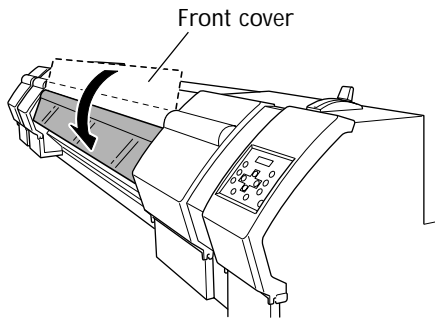

Close the front cover.

2

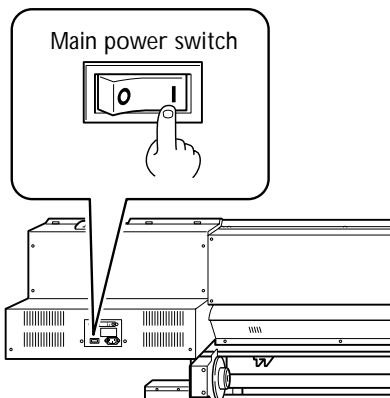

Switch on the main power switch.

3

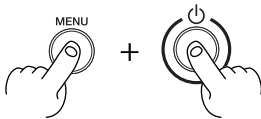

Hold down **MENU** and press the sub power switch.

4

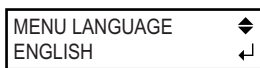

Use **▲** **▼** to select the language you want.  
Press **ENTER**.

5



Use **▲** **▼** to select the unit of measurement you want (for length).  
Press **ENTER**.



## 2. Insert the ink cartridges for the respective colors.

1 SELECT INK TYPE  
SUBLIMATION 4C ↵

Make sure the ink type matches the ink cartridges.  
Press **ENTER**.

2 INSTALL  
DRAIN BOTTLE ↵

Make sure the drain bottle is installed.  
Press **ENTER**.

3 SET CARTRIDGE  
1 2 3 4 5 6 7 8

Insert the ink cartridges for each color.

↓  
FILLING INK...  
>>

Insert into the slot of  
the matching color

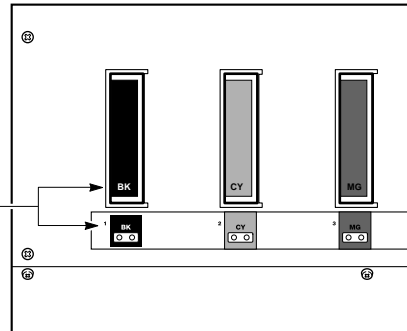

4 SETUP SHEET

When this screen appears, cleaning is finished.

# 6. Adjusting the Sensor's Position

## Adjusting the Positioning of the Take-up Unit Sensor

In order to take up media during printing using the take-up unit, the location of the sensor must be adjusted.

### Procedure

- 1 Turn on the main power switch of the take-up unit.  
Two LEDs (green and red) light up.

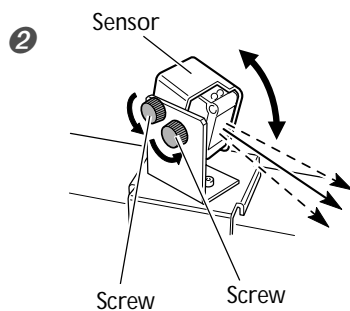
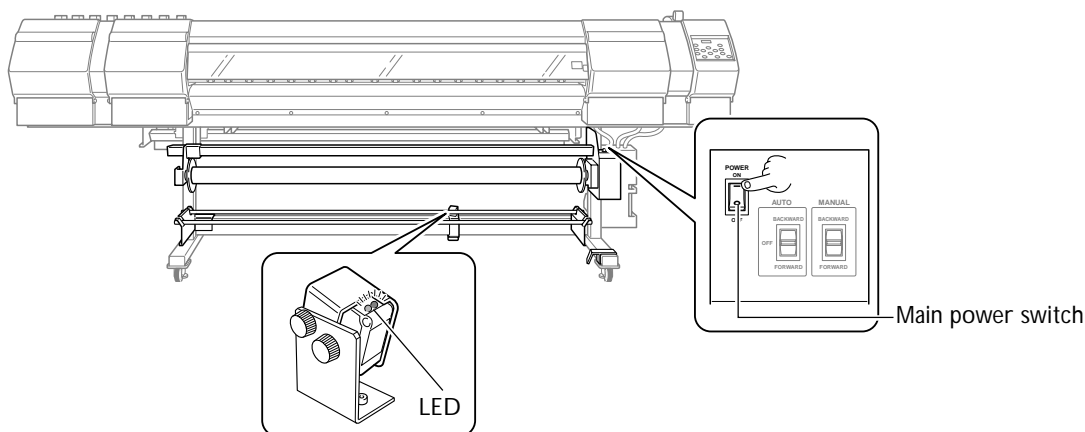

Loosen the screw, and adjust the angle of the sensor so that it is aligned with the mirror.

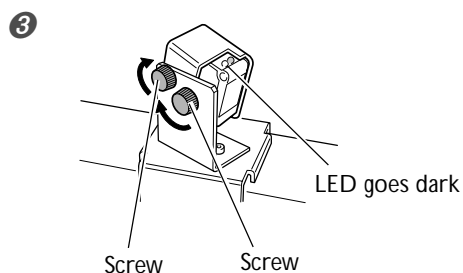

Tighten the adjustment screw securely at the angle where the red LED has gone dark.

### Sensor detection area

Media that is fed out here is taken up automatically.

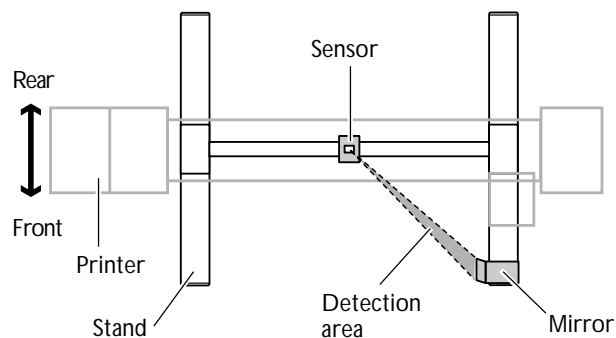





1000002736

R2-070228