

ADVANCED JET

AJ-1000i AJ-740i USER'S MANUAL

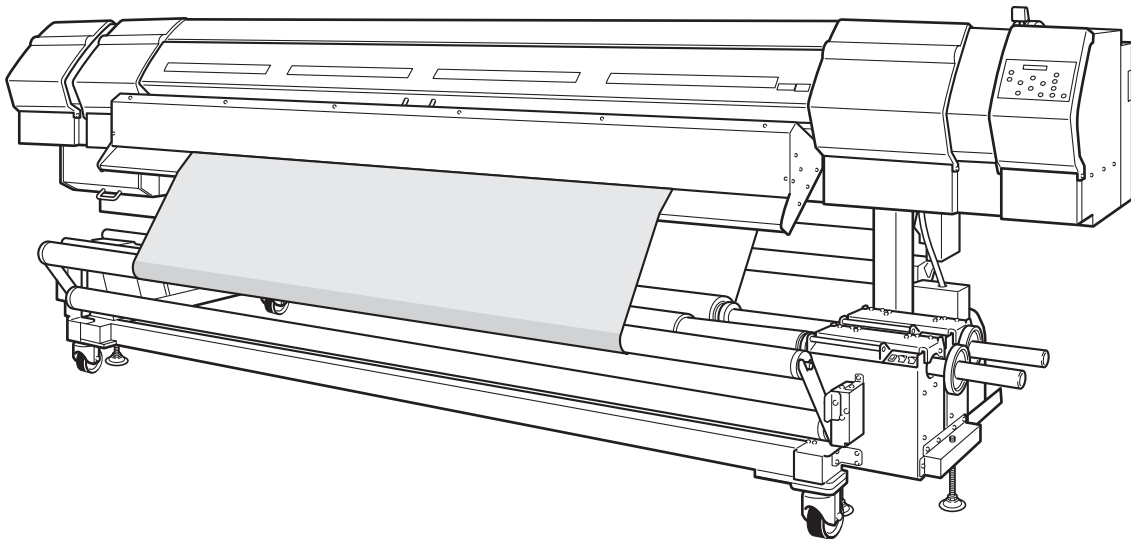

Thank you very much for purchasing this product.

- To ensure correct and safe usage with a full understanding of this product's performance, please be sure to read through this manual completely and store it in a safe location.
 - Unauthorized copying or transferral, in whole or in part, of this manual is prohibited.
 - The contents of this operation manual and the specifications of this product are subject to change without notice.
 - The operation manual and the product have been prepared and tested as much as possible. If you find any misprint or error, please inform us.
 - Roland DG Corp. assumes no responsibility for any direct or indirect loss or damage which may occur through use of this product, regardless of any failure to perform on the part of this product.
 - Roland DG Corp. assumes no responsibility for any direct or indirect loss or damage which may occur with respect to any article made using this product.
-

For USA

FEDERAL COMMUNICATIONS COMMISSION RADIO FREQUENCY INTERFERENCE STATEMENT

NOTE: This equipment has been tested and found to comply with the limits for a Class A digital device, pursuant to part 15 of the FCC Rules.

These limits are designed to provide reasonable protection against harmful interference when the equipment is operated in a commercial environment.

This equipment generates, uses, and can radiate radio frequency energy and, if not installed and used in accordance with the instruction manual, may cause harmful interference to radio communications.

Operation of this equipment in a residential area is likely to cause harmful interference in which case the user will be required to correct the interference at his own expense.

Unauthorized changes or modification to this system can void the users authority to operate this equipment.

NOTICE

Grounding Instructions

In the event of a malfunction or breakdown, grounding provides a path of least resistance for electric current to reduce the risk of electric shock. This tool is equipped with an electric cord having an equipment-grounding conductor and a grounding plug. The plug must be plugged into a matching outlet that is properly installed and grounded in accordance with all local codes and ordinances.

Do not modify the plug provided - if it will not fit the outlet, have the proper outlet installed by a qualified electrician.

Improper connection of the equipment-grounding conductor can result in a risk of electric shock. The conductor with insulation having an outer surface that is green with or without yellow stripes is the equipment-grounding conductor. If repair or replacement of the electric cord or plug is necessary, do not connect the equipment-grounding conductor to a live terminal.

Check with a qualified electrician or service personnel if the grounding instructions are not completely understood, or if in doubt as to whether the tool is properly grounded.

Use only 3-wire extension cords that have 3-prong grounding plugs and 3-pole receptacles that accept the tool's plug.

Repair or replace damaged or worn cord immediately.

For Canada

CLASS A NOTICE

This Class A digital apparatus meets all requirements of the Canadian Interference-Causing Equipment Regulations.

CLASSE A AVIS

Cet appareil numérique de la classe A respecte toutes les exigences du Règlement sur le matériel brouilleur du Canada.

For California

WARNING

This product contains chemicals known to cause cancer, birth defects and other reproductive harm, including lead.

For EU Countries

WARNING

This is a Class A product. In a domestic environment this product may cause radio interference in which case the user may be required to take adequate measures.

For EU Countries





Manufacturer:
ROLAND DG CORPORATION
1-6-4 Shinmiyakoda, Kita-ku, Hamamatsu-shi, Shizuoka-ken, 431-2103 JAPAN

The authorized representative on the EU:
Roland DG Corporation, German Office Halskestr.7 47877 Willich,Germany

Roland DG Corp. has licensed the MMP technology from the TPL Group.

Contents

 To Ensure Safe Use.....	4
 Pour utiliser en toute sécurité	11
Important Notes on Handling and Use	18
Printer unit	18
Ink cartridges	19
Chapter 1 Introduction	21
1-1 Machine Features	22
1-2 Part Names and Functions	23
Printer Unit	23
Operation Panel	25
Media Take-up and Feed Systems	26
Chapter 2 Basic Operation	29
2-1 Switching the Power On and Off	30
Switching the Power On and Off	30
The Power-saving Feature.....	31
2-2 Loading and Cutting Off Media	32
How to Load Media.....	32
How to Cut Off Media	47
2-3 Settings of the Media Heating System.....	48
What Is the Media Heating System?.....	48
Making the Temperature Setting for the Media Heating System	48
General Guide for the Preset Temperatures.....	49
2-4 Starting Printing	50
Getting Ready to Receive Data from a Computer	50
Printing Tests and Cleaning	51
2-5 If Ink Runs Out	53
Checking for Remaining Ink.....	53
When Ink Cartridges Become Empty	54
Chapter 3 Maintenance and Adjustment	57
3-1 Daily Care and Maintenance.....	58
Disposing of Discharged Ink	58
Cleaning.....	60
Care and Maintenance of the Print Heads.....	61
3-2 When Head Cleaning Is Not Effective.....	62
Performing More Powerful Cleaning.....	62
When Powerful Cleaning Is Not Effective	63
3-3 Cleaning the Heads Using the Cleaning Kit.....	64
When the Cleaning Kit Becomes Necessary	64
How to Perform Cleaning.....	64
3-4 Replacing Consumable Parts	68
Replacing the Wipers	68
Replacing the Maintenance Liquid Cartridge	71
3-5 When Not in Use for a Prolonged Period	75
Important Points to Observe.....	75
3-6 When Moving the Machine	76
Chapter 4 Feature Reference	77
4-1 Pausing or Canceling Printing	78
Canceling Printing Before It Finishes.....	78

4-2	Setting the Printing Position and Margins	79
	Shifting the Print-start Position to the Rear	79
	Shifting the Printing Position to the Left	79
4-3	Making Simple Changes to the Printer Settings to Match the Media	80
	Saving Optimized Media Settings As Preset Values	80
	Loading a Saved Preset	81
	Assigning a Name to a Preset.....	81
4-4	Optimizing Printing to Match Media Thickness	82
	Adjusting Head Height to Match Media Thickness.....	82
	Correcting for Misalignment in Bidirectional Printing	83
	Correcting for Misalignment in Bidirectional Printing More Precisely	84
	Performing Feed Correction to Alleviate Horizontal Bands and the Like	86
	Changing the Feed-correction Value During Printing	87
4-5	Accommodating Various Kinds of Media.....	88
	Using Transparent Media	88
	Preventing Media from Coming Loose.....	90
	Speeding Up Printing for Narrow Media.....	91
	Keeping Media from Being Soiled by Ink Drips.....	91
4-6	Changing How the Printer Operates	93
	Determining What Happens When an Ink Cartridge Is Empty	93
	Setting the Interval until Activation of the Sleep Mode.....	93
	Deactivating the Sleep Mode	94
	Changing the Menu Language and the Units of Measurement	94
	Drying the Trailing Edge of the Printing Area on the Dryer	95
	Returning All Settings to Their Initial Values.....	95
	Changing the Self-cleaning Settings.....	96
	Changing the Type of Ink.....	96
4-7	Changing the Ink-drying Method	97
	Switching Off the Preheater, Print Heater, or Dryer	97
	Determining How the Media Heating System Operates.....	97
	Switching the Blower Fan On and Off.....	98
4-8	Recording the Amount of Remaining Media	99
	Displaying the Amount of Remaining Media on the Screen.....	99
	Verifying the Setting for the Amount Remaining Every Time the Media Is Changed	99
	Printing the Amount of Remaining Media	100
4-9	Viewing System Information.....	101
	Viewing the Serial Number, Firmware Version, and Other Information	101
	Printing a System Report	101
4-10	Menu List	102
	Main menu.....	102
	Language and Unit Menu.....	106
	Cleaning Menu	106
	Media Heating System Configuration Menu	106
Chapter 5 What to Do If		107
5-1	The Machine Doesn't Run.....	108
	The Printer Unit Doesn't Run.....	108
	The Media Take-up or Feed System Doesn't Run	108
	The Dryer Doesn't Warm Up	108
	The Preheater and Print Heater Don't Warm Up.....	108
5-2	Attractive Printing Is Impossible	109
	Printed Results Are Coarse or Contain Horizontal Stripes	109
	Colors Are Unstable or Uneven	109
	The Media Becomes Soiled When Printed	110
5-3	The Media Jams	111
	The Media Jams.....	111

5-4 The Media Cannot Be Taken Up Smoothly	112
The Media Cannot Be Taken Up Smoothly	112
5-5 Media Wrinkles or Shrinks, or Feed Is Unstable	113
Media Wrinkles or Shrinks	113
The Media Is Not Straight	113
Media Feed Is Not Smooth	113
5-6 The Print Heads Stopped Moving	114
What to Do First	114
If the Heads Still Do Not Move	114
5-7 If a Message Appears	115
5-8 If an Error Message Appears	116
Chapter 6 Specifications	119
6-1 Usable Media	120
Conditions for Usable Media	120
6-2 Printing Area	121
Printing Area and Margins	121
6-3 Locations of the Power Rating and Serial Number Labels	122
6-4 Specifications	123

This document is the Setup Guide for both the AJ-1000i and the AJ-740i. For the most part, the illustrations used in this document depict the AJ-1000i.



Company names and product names are trademarks or registered trademarks of their respective holders.





To Ensure Safe Use

Improper handling or operation of this machine may result in injury or damage to property. Points which must be observed to prevent such injury or damage are described as follows.

About WARNING and CAUTION Notices

 WARNING	Used for instructions intended to alert the user to the risk of death or severe injury should the unit be used improperly.
 CAUTION	Used for instructions intended to alert the user to the risk of injury or material damage should the unit be used improperly. * Material damage refers to damage or other adverse effects caused with respect to the home and all its furnishings, as well to domestic animals or pets.

About the Symbols

	The  symbol alerts the user to important instructions or warnings. The specific meaning of the symbol is determined by the design contained within the triangle. The symbol at left means "danger of electrocution."
	The  symbol alerts the user to items that must never be carried out (are forbidden). The specific thing that must not be done is indicated by the design contained within the circle. The symbol at left means the unit must never be disassembled.
	The  symbol alerts the user to things that must be carried out. The specific thing that must be done is indicated by the design contained within the circle. The symbol at left means the power-cord plug must be unplugged from the outlet.

 **Incorrect operation may cause injury**

 **WARNING**

 **Be sure to follow the operation procedures described in this documentation. Never allow anyone unfamiliar with the usage or handling of the machine to touch it.**

Incorrect usage or handling may lead to an accident.

 **Keep children away from the machine.**
The machine includes areas and components that pose a hazard to children and may result in injury, blindness, choking, or other serious accident.

 **Never operate the machine while tired or after ingesting alcohol or any medication.**
Operation requires unimpaired judgment. Impaired judgment may result in an accident.

 **Never use the machine for any purpose for which it is not intended, or use the machine in an undue manner that exceeds its capacity.**
Doing so may result in injury or fire.

 **For accessories (optional and consumable items, AC adapter, power cord, and the like), use only genuine articles compatible with this machine.**
Incompatible items may lead to an accident.

 **When attempting cleaning, maintenance, or attachment or detachment of optional items, follow the instructions given in this guide.**
Incorrect operation or handling may result in injury or electrical shock.

 **Never attempt to disassemble, repair, or modify the machine.**
Doing so may result in fire, electrical shock, or injury. Entrust repairs to a trained service technician.

 **CAUTION**

 **Exercise caution to avoid being pinched or becoming caught.**
Inadvertent contact with certain areas may cause the hand or fingers to be pinched or become caught. Use care when performing operations.

 **Never attempt operation while wearing a necktie, necklace, or loose clothing. Bind long hair securely.**
Such items may become caught in the machine, resulting in injury.

 **Conduct operations in a clean, brightly lit location.**
Working in a location that is dark or cluttered may lead to an accident, such as becoming caught in the machine as the result of an inadvertent stumble.

 **Never climb or lean on the machine.**
The machine is not made to support a person. Climbing or leaning on the machine may dislodge components and cause a slip or fall, resulting in injury.

 **Danger of electrical short, shock, electrocution, or fire**

 **WARNING**

-  **Connect to an electrical outlet that complies with this machine's ratings (for voltage, frequency, and current).**
Incorrect voltage or insufficient current may cause fire or electrical shock.

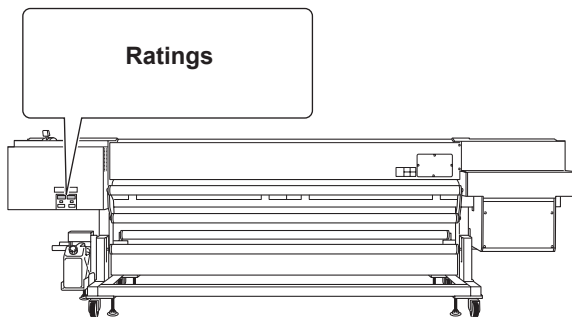



-  **Never use out of doors or in any location where exposure to water or high humidity may occur. Never touch with wet hands.**
Doing so may result in fire or electrical shock.

-  **Never allow any foreign object to get inside. Never expose to liquid spills.**
Inserting objects such as coins or matches or allowing beverages to be spilled into the ventilation ports may result in fire or electrical shock. If anything gets inside, immediately disconnect the power cord and contact your authorized Roland DG Corp. dealer.

-  **Never place any flammable object nearby. Never use a combustible aerosol spray nearby. Never use in any location where gases can accumulate.**
Combustion or explosion may be a danger.

 **WARNING**

-  **Handle the power cord, plug, and electrical outlet correctly and with care. Never use any article that is damaged.**
Using a damaged article may result in fire or electrical shock.

-  **When using an extension cord or power strip, use one that adequately satisfies the machine's ratings (for voltage, frequency, and current).**
Use of multiple electrical loads on a single electrical outlet or of a lengthy extension cord may cause fire.

-  **Connect to ground.**
This can prevent fire or electrical shock due to current leakage in the event of malfunction.

-  **Position so that the power plug is within immediate reach at all times.**
This is to enable quick disconnection of the power plug in the event of an emergency. Install the machine next to an electrical outlet. Also, provide enough empty space to allow immediate access to the electrical outlet.

-  **If sparking, smoke, burning odor, unusual sound, or abnormal operation occurs, immediately unplug the power cord. Never use if any component is damaged.**
Continuing to use the machine may result in fire, electrical shock, or injury. Contact your authorized Roland DG Corp. dealer.

⚠ Important notes about the power cord, plug, and electrical outlet

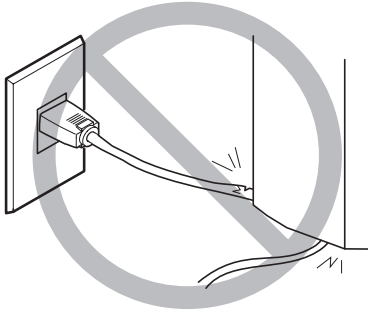

Never place any object on top or subject to damage.

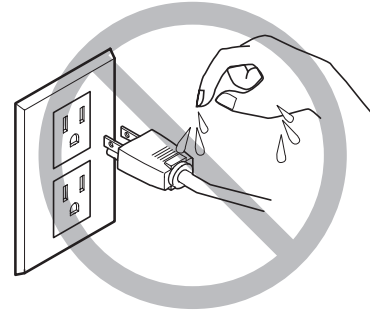

Never allow to get wet.

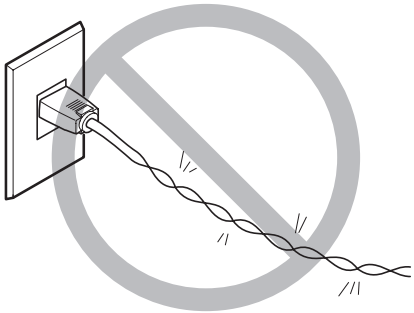

Never bend or twist with undue force.

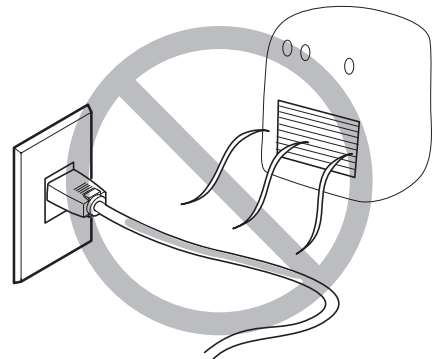

Never make hot.

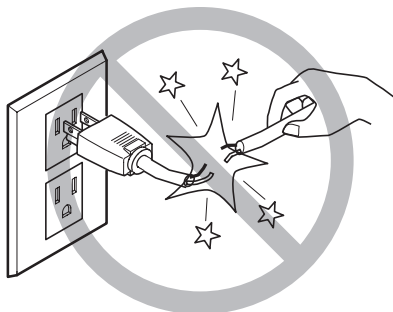

Never pull with undue force.

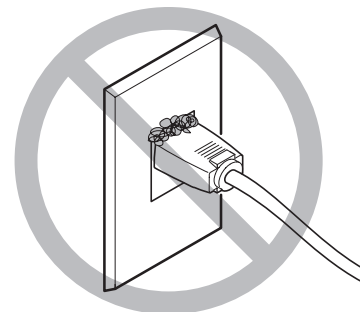

Dust may cause fire.

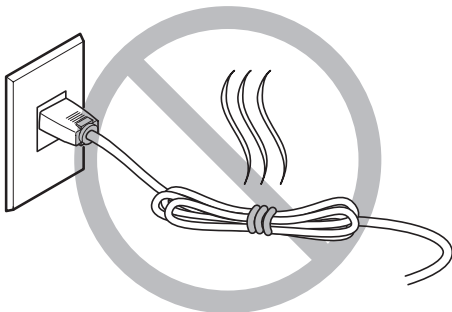

Never bundle, bind, or roll up.

 **Ink, maintenance liquid, and discharged fluid are flammable and toxic**

 **WARNING**

 **Keep open flame away from the work area.**
Ink and discharged fluid are flammable.

 **Never store ink, maintenance liquid, or discharged fluid in any of the following locations.**

- Any location exposed to open flame
- Any location where high temperature may occur
- Near bleach or any other such oxidizing agent or explosive material
- Any location within the reach of children

Fire may be a danger. Accidental ingestion by children may pose a health hazard.

 **Never place an ink cartridge in fire.**
Ink may flow out, catch fire, and spread fire to other nearby objects.

 **Never drink or sniff ink, maintenance liquid, or discharged fluid, or allow them to come in contact with the eyes or skin.**
Doing so may be hazardous to the health.

 **CAUTION**

 **Ensure adequate ventilation for the work area.**
Failing to perform ventilation may result in a health hazard or danger of combustion due to ink fumes.

 **Never allow an ink cartridge to be subjected to impact, and never attempt to disassemble.**
Ink may leak.

 **In the event of ingestion or physical distress**

- In the event of contact with the eyes, immediately flush with water for at least 15 minutes. If eye irritation continues, seek treatment by a physician.
- In the event of contact with skin, immediately wash with soap. If irritation or inflammation occur, seek treatment by a physician.
- In the event of ingestion, do not induce vomiting, and immediately seek treatment by a physician. Forcibly inducing vomiting may lead to danger of choking.
- If odor leads to physical distress, move to a well-ventilated location and rest quietly. If dizziness or nausea persists, seek treatment by a physician.

 **This machine weighs 700 kilograms (1,543 lb.).
Media weighs 100 kilograms (220 lb.).**

 **WARNING**

 **Entrust operations such as transportation, unloading, and emplacement to trained workers.**

Handling requires special equipment and training. Performing operations in an unreasonable manner may result in a major accident.

 **Install the machine in a location that is level, stable, and able to bear the weight of the machine.**

The total weight of the machine is can reach 700 kilograms (1,543 lb.) or more (580 kilograms (1,279 lb.) or more for the AJ-740i). Installation in an unsuitable location may cause a major accident, including tipover, fall, or collapse.

 **Be sure to anchor the stand to the floor.**
If the machine should begin to topple, a major accident may result, including crushing of the appendages or the body.

 **WARNING**

 **When loading or moving roll media, use lifting equipment, and exercise care to prevent falls.**

Attempting manual lifting of heavy media that taxes your strength may cause physical injury. Also, if dropped, such items may cause injury.

 **When storing roll media, implement adequate safety measures to ensure that the stored media will not roll, fall, or topple over.**

Danger exists of becoming pinned under the media and suffering serious injury.

 **Danger of fire, burns, or toxic gas emissions**

 **WARNING**

 **Caution: high temperatures.**
Areas such as the dryer become hot. Exercise caution to avoid fire or burns.

 **When printing is not being performed, remove any loaded media or switch off the power.**

The continued application of heat at a single location may cause the release of toxic gases from the media or pose a fire hazard.

 **WARNING**

 **Never use media that cannot withstand heat.**

Doing so may degrade the media, or may result in fire or the release of toxic gases.

Warning Labels

Warning labels are affixed to make areas of danger immediately clear. The meanings of these labels are as follows. Be sure to heed their warnings.

Also, never remove the labels or allow them to become obscured.

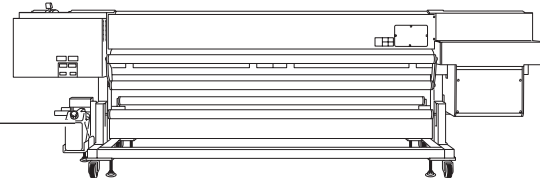
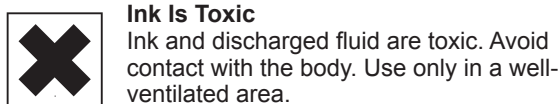
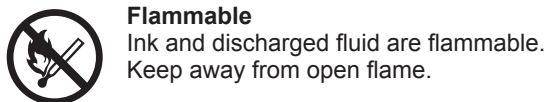
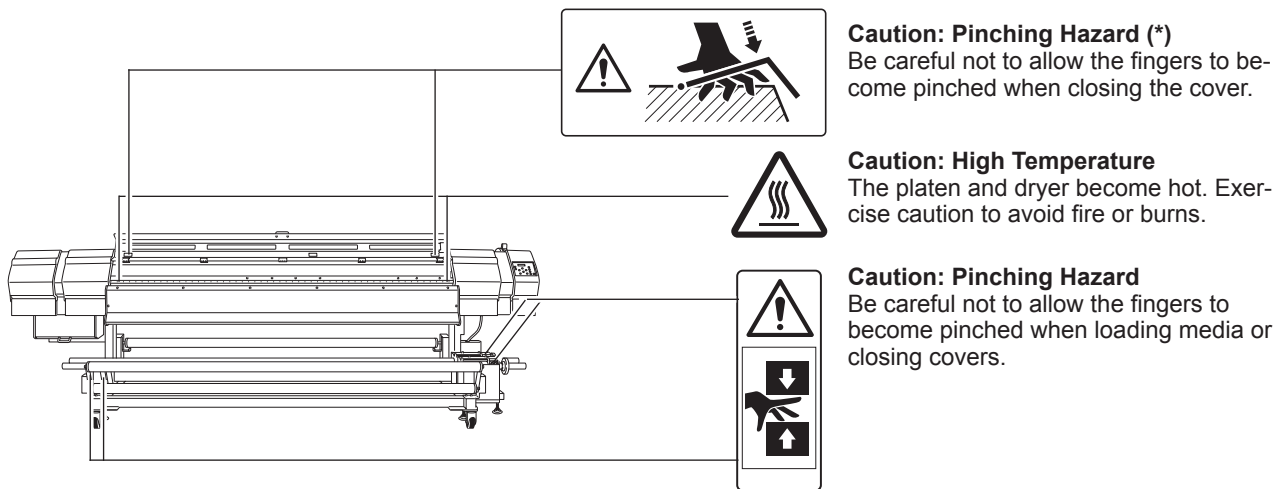
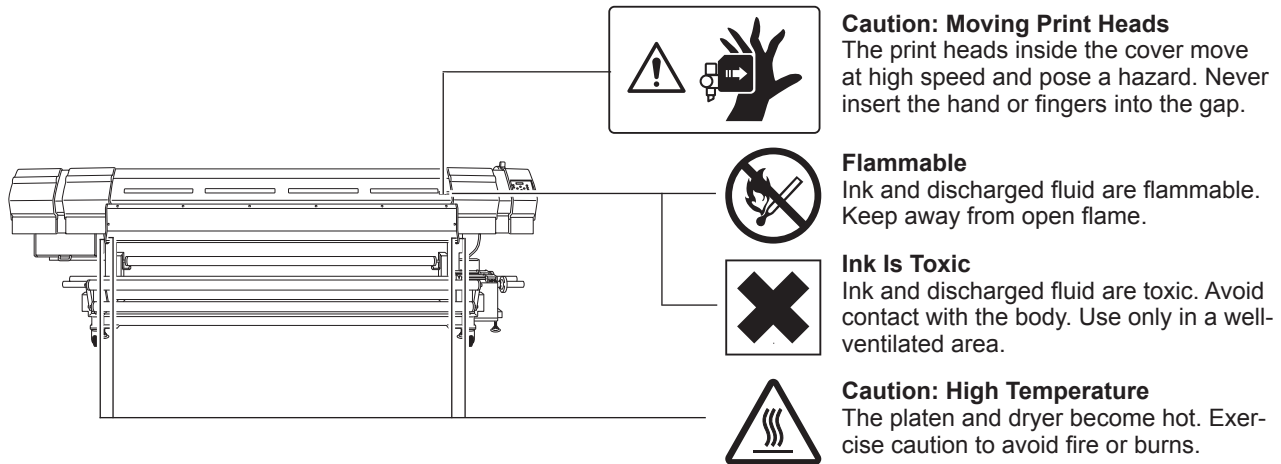



* Affixed on the AJ-1000i only.





Pour utiliser en toute sécurité

La manipulation ou l'utilisation inadéquates de cet appareil peuvent causer des blessures ou des dommages matériels. Les précautions à prendre pour prévenir les blessures ou les dommages sont décrites ci-dessous.

Avis sur les avertissements

 ATTENTION	Utilisé pour avertir l'utilisateur d'un risque de décès ou de blessure grave en cas de mauvaise utilisation de l'appareil.
 PRUDENCE	Utilisé pour avertir l'utilisateur d'un risque de blessure ou de dommage matériel en cas de mauvaise utilisation de l'appareil. * Par dommage matériel, il est entendu dommage ou tout autre effet indésirable sur la maison, tous les meubles et même les animaux domestiques.

À propos des symboles

	Le symbole \triangle attire l'attention de l'utilisateur sur les instructions importantes ou les avertissements. Le sens précis du symbole est déterminé par le dessin à l'intérieur du triangle. Le symbole à gauche signifie "danger d'électrocution".
	Le symbole \otimes avertit l'utilisateur de ce qu'il ne doit pas faire, ce qui est interdit. La chose spécifique à ne pas faire est indiquée par le dessin à l'intérieur du cercle. Le symbole à gauche signifie que l'appareil ne doit jamais être démonté.
	Le symbole \bullet prévient l'utilisateur sur ce qu'il doit faire. La chose spécifique à faire est indiquée par le dessin à l'intérieur du cercle. Le symbole à gauche signifie que le fil électrique doit être débranché de la prise.

L'utilisation incorrecte peut causer des blessures

ATTENTION

 **S'assurer de suivre les procédures d'utilisation décrites dans la documentation. Ne jamais permettre à quiconque ne connaît pas le fonctionnement ou la manutention de l'appareil de le toucher.** L'utilisation ou la manutention incorrectes peuvent causer un accident.

 **Garder les enfants loin de l'appareil.** L'appareil comporte des zones et des composants qui présentent un danger pour les enfants et qui pourraient causer des blessures, la cécité, la suffocation ou d'autres accidents graves.

 **Ne jamais faire fonctionner l'appareil après avoir consommé de l'alcool ou des médicaments, ou dans un état de fatigue.** L'utilisation de l'appareil exige un jugement sans faille. L'utilisation avec les facultés affaiblies pourrait entraîner un accident.

 **Ne jamais utiliser l'appareil à des fins autres que celles pour lesquelles il est conçu. Ne jamais l'utiliser de manière abusive ou d'une manière qui dépasse sa capacité.** Le non-respect de cette consigne peut causer des blessures ou un incendie.

 **Utiliser uniquement des accessoires d'origine (accessoires en option, articles consommables, adaptateur CA, câble d'alimentation et autres articles semblables), compatibles avec l'appareil.** Les articles incompatibles risquent de causer des accidents.

 **Suivre les instructions données dans ce guide pour le nettoyage, l'entretien, l'installation ou le retrait des accessoires en option.** La manipulation ou l'utilisation incorrectes risquent de causer des blessures ou un choc électrique.

ATTENTION

 **Ne jamais tenter de démonter, de réparer ou de modifier l'appareil.** Le non-respect de cette consigne risque de provoquer un incendie, un choc électrique ou des blessures. Confier les réparations à un technicien ayant la formation requise.

PRUDENCE

 **Faire preuve de prudence pour éviter l'écrasement ou le coincement.** La main ou les doigts peuvent être écrasés ou coincés s'ils entrent en contact avec certaines surfaces par inadvertance. Faire preuve de prudence pendant l'utilisation de l'appareil.

 **Ne jamais faire fonctionner l'appareil si on porte une cravate, un collier ou des vêtements amples. Bien attacher les cheveux longs.** Ces vêtements ou ces objets peuvent être coincés dans l'appareil, ce qui causerait des blessures.

 **Utiliser l'appareil dans un endroit propre et bien éclairé.** Travailler dans un endroit sombre ou encombré peut causer un accident; l'utilisateur risque, par exemple, de trébucher malencontreusement et d'être coincé par une partie de l'appareil.

 **Ne jamais grimper ni s'appuyer sur la machine.** La machine n'est pas conçue pour supporter le poids d'une personne. Grimper ou s'appuyer sur la machine peut déplacer des éléments et causer un faux pas ou une chute, ce qui causerait des blessures.

⚠ Risque de décharge ou de choc électrique, d'électrocution ou d'incendie

⚠ ATTENTION



Brancher à une prise électrique conforme aux caractéristiques de cet appareil (tension, fréquence et courant).

Une tension incorrecte ou un courant insuffisant peuvent causer un incendie ou un choc électrique.

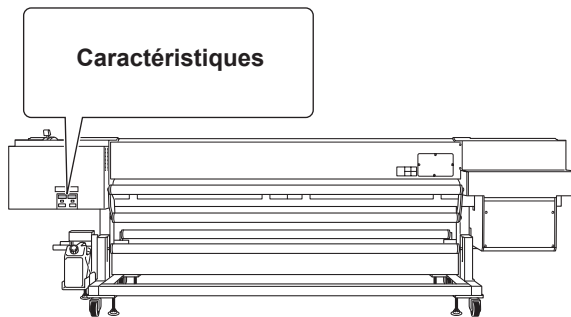

Ne jamais utiliser à l'extérieur ni à un endroit où l'appareil risque d'être exposé à de l'eau ou à une humidité élevée. Ne jamais toucher l'appareil avec des mains mouillées.

Le non-respect de cette consigne risque de provoquer un incendie ou un choc électrique.



Ne jamais insérer d'objet étranger dans l'appareil. Ne jamais exposer l'appareil aux déversements de liquides.

L'insertion d'objets comme des pièces de monnaie ou des allumettes, ou le déversement de liquides dans les orifices de ventilation peuvent causer un incendie ou un choc électrique. Si un objet ou du liquide s'infiltré dans l'appareil, débrancher immédiatement le câble d'alimentation et communiquer avec le représentant Roland DG Corp. autorisé.



Ne jamais placer d'objet inflammable à proximité de l'appareil. Ne jamais utiliser de produit inflammable en aérosol à proximité de l'appareil. Ne jamais utiliser l'appareil dans un endroit où des gaz peuvent s'accumuler.

Une combustion ou une explosion pourraient se produire.

⚠ ATTENTION



Manipuler le câble d'alimentation, la fiche et la prise électrique correctement et avec soin.

Ne jamais utiliser un article endommagé, car cela pourrait causer un incendie ou un choc électrique.



Si une rallonge ou une bande d'alimentation électrique sont utilisées, s'assurer qu'elles correspondent aux caractéristiques de l'appareil (tension, fréquence et courant).

L'utilisation de plusieurs charges électriques sur une prise unique ou une longue rallonge peut causer un incendie.



Mise à la terre.

La mise à la terre peut prévenir un incendie ou un choc électrique dus à une fuite de courant en cas de défaillance.



Placer l'appareil de façon à ce que la fiche soit facile d'accès en tout temps.

Ainsi, l'appareil pourra être débranché rapidement en cas d'urgence. Installer l'appareil près d'une prise électrique. En outre, prévoir suffisamment d'espace pour que la prise électrique soit facile d'accès.



S'il se produit des étincelles, de la fumée, une odeur de brûlé, un bruit inhabituel ou un fonctionnement anormal, débrancher immédiatement le câble d'alimentation. Ne jamais utiliser si un composant est endommagé.

Continuer à utiliser l'appareil peut causer un incendie, un choc électrique ou des blessures. Communiquer avec le représentant Roland DG Corp. Autorisé.

⚠ Remarques importantes à propos du câble d'alimentation, de la fiche et de la prise électrique

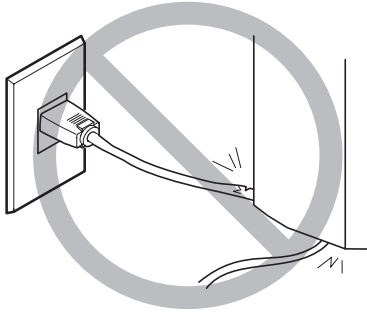

Ne jamais déposer aucun objet sur le câble, sur la fiche ou sur la prise car cela risque de les endommager.

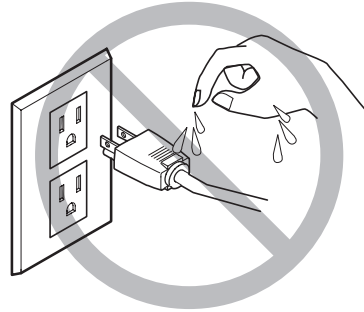

Ne jamais laisser l'eau toucher le câble, la fiche ou la prise.

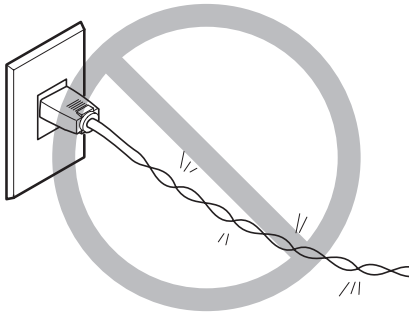

Ne jamais plier ni tordre le câble avec une force excessive.

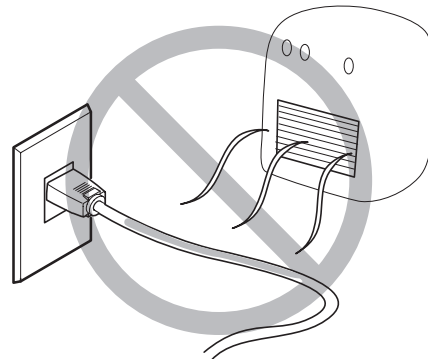

Ne jamais chauffer le câble, la fiche ou la prise.

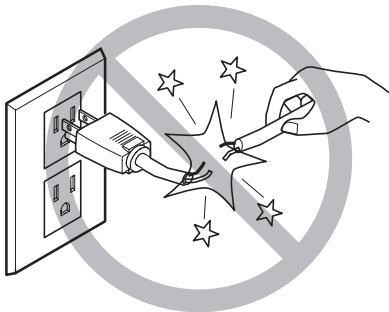

Ne jamais tirer sur le câble ou la fiche avec une force excessive.

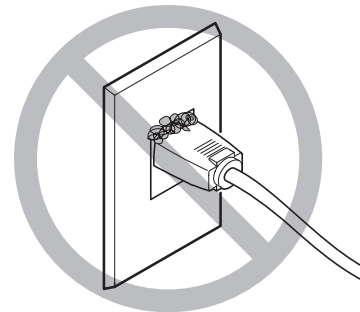

La poussière peut causer un incendie.

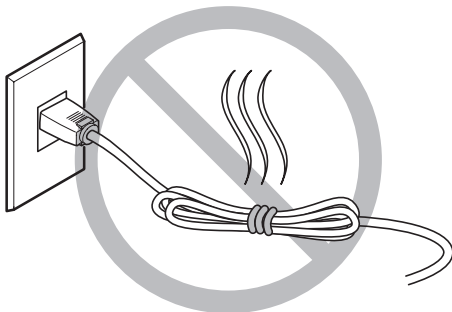

Ne jamais plier ni enrouler le câble.

 **L'encre, les liquides nettoyants et les liquides usés sont inflammables et toxiques**

 **ATTENTION**



Ne pas approcher une flamme nue de l'espace de travail.

L'encre et les liquides usés sont inflammables.



Ne jamais entreposer d'encre, de liquide de nettoyage ou d'entretien ni de liquides usés dans les endroits suivants :

- un endroit exposé à une flamme nue;
 - un endroit où il y a risque de température élevée;
 - près d'eau de Javel, d'un autre agent d'oxydation ou de matériel explosif;
 - tout endroit à la portée d'enfants.
- Il y a risque d'incendie. L'ingestion accidentelle par un enfant peut présenter un risque pour la santé.



Ne jamais incinérer une cartouche d'encre.

De l'encre pourrait couler, s'enflammer et le feu se répandre à des objets proches.



Ne jamais boire l'encre, le liquide de nettoyage ou d'entretien ni les liquides usés, ne pas en respirer les vapeurs et ne pas laisser ces produits entrer en contact avec les yeux ou la peau.

Cela est dangereux pour la santé.

 **PRUDENCE**



S'assurer que le lieu de travail est bien aéré.

L'absence d'aération adéquate peut créer une situation dangereuse pour la santé ou un risque de combustion à cause des vapeurs qui émanent de l'encre.



Ne jamais soumettre une cartouche d'encre à des chocs. Ne jamais tenter d'ouvrir une cartouche d'encre.

De l'encre pourrait s'échapper.

 **En cas d'ingestion ou de trouble physique**

- En cas de contact avec les yeux : rincer immédiatement et abondamment à l'eau courante pendant au moins 15 minutes. Si les yeux sont toujours irrités, consulter un médecin.
- En cas de contact avec la peau : laver immédiatement à l'eau et au savon. En cas d'irritation ou d'inflammation de la peau : consulter un médecin.
- En cas d'ingestion : ne pas provoquer le vomissement et demander immédiatement l'aide d'un médecin. Provoquer le vomissement peut créer un risque de suffocation.
- Si l'odeur cause un trouble physique, amener la personne dans un endroit bien aéré et la faire se reposer. Si l'étourdissement ou la nausée persistent, consulter un médecin.

 **Le poids de cet appareil est de 700 kilogrammes (1,543 lb.).
Le poids du support est de 100 kilogrammes (220 lb.).**

ATTENTION

 **Confier les opérations comme le transport, le déchargement et la mise en place à des travailleurs qui ont reçu la formation requise.**

La manutention exige de la formation et de l'équipement spécialisés. Tenter de procéder à ces opérations de manière intempestive peut provoquer un accident grave.

 **Installer l'appareil à un endroit stable et plat et capable de supporter son poids.**

Le poids total de cet appareil peut être de 700 kilogrammes(1,543 lb.) ou plus (580 kilogrammes(1,279 lb.) ou plus pour le AJ-740i). Installer l'appareil à un endroit inapproprié peut provoquer un accident grave comme le renversement, la chute ou l'écrasement.

 **S'assurer d'ancrer la base de l'appareil au sol.**

Si l'appareil devait commencer à basculer, il s'ensuivrait un accident grave, par exemple l'écrasement de membres ou du corps.

ATTENTION

 **Lors du chargement ou du déplacement de support en rouleau, utiliser de l'équipement de levage et faire preuve de prudence pour éviter les chutes.**

Tenter de soulever manuellement des objets trop lourds peut causer des blessures. En outre, si ces objets sont échappés, ils peuvent causer des blessures.

 **Prendre les mesures de sécurité adéquates pour l'entreposage des rouleaux de support pour s'assurer qu'ils ne rouleront pas, ne tomberont pas et ne se renverseront pas.**

Il y a risque d'être écrasé par le support et de subir des blessures graves.

 **Risque d'incendie, de brûlures ou d'émissions de gaz toxiques.**

ATTENTION

 **Attention : températures élevées.**
Les zones comme le séchoir chauffent. Faire preuve de prudence pour éviter un incendie ou des brûlures.

 **Quand aucun travail d'impression n'est en cours, retirer tout support de l'appareil ou couper l'alimentation électrique.**

L'application continue de chaleur à un point unique peut causer l'émission de gaz toxiques ou créer un risque d'incendie.

ATTENTION

 **Ne jamais utiliser un support qui ne peut pas supporter la chaleur.**

L'utilisation d'un support qui ne supporte pas la chaleur peut détériorer le support, créer un risque d'incendie ou causer l'émission de gaz toxiques.

⚠ Vignettes d'avertissement

Des vignettes d'avertissement sont apposées pour qu'il soit facile de repérer les zones dangereuses. La signification des vignettes est donnée ci-dessous. Respecter les avertissements. Ne jamais retirer les vignettes et ne pas les laisser s'encrasser.

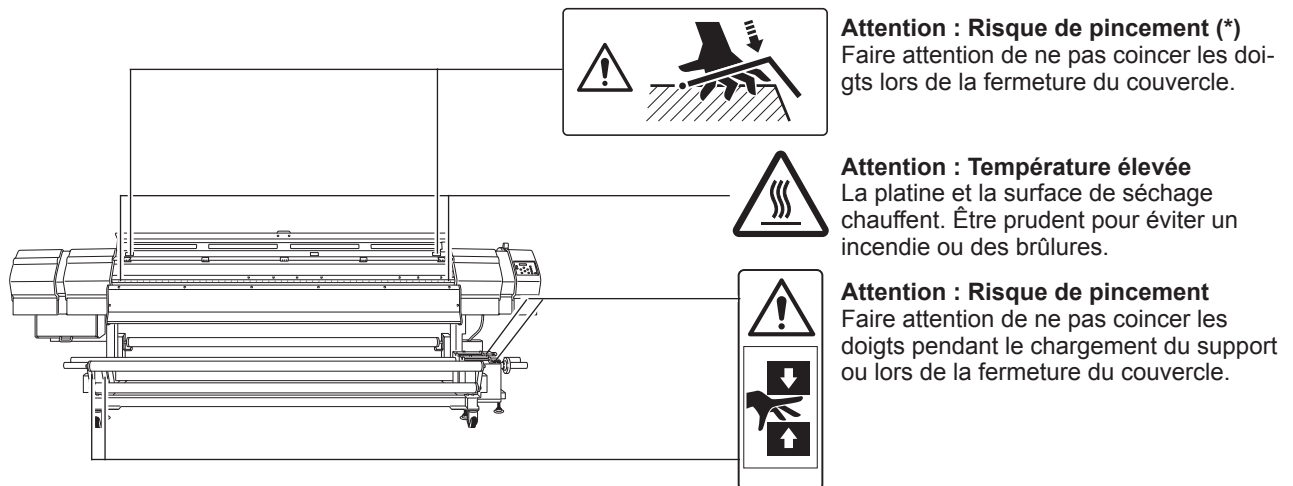
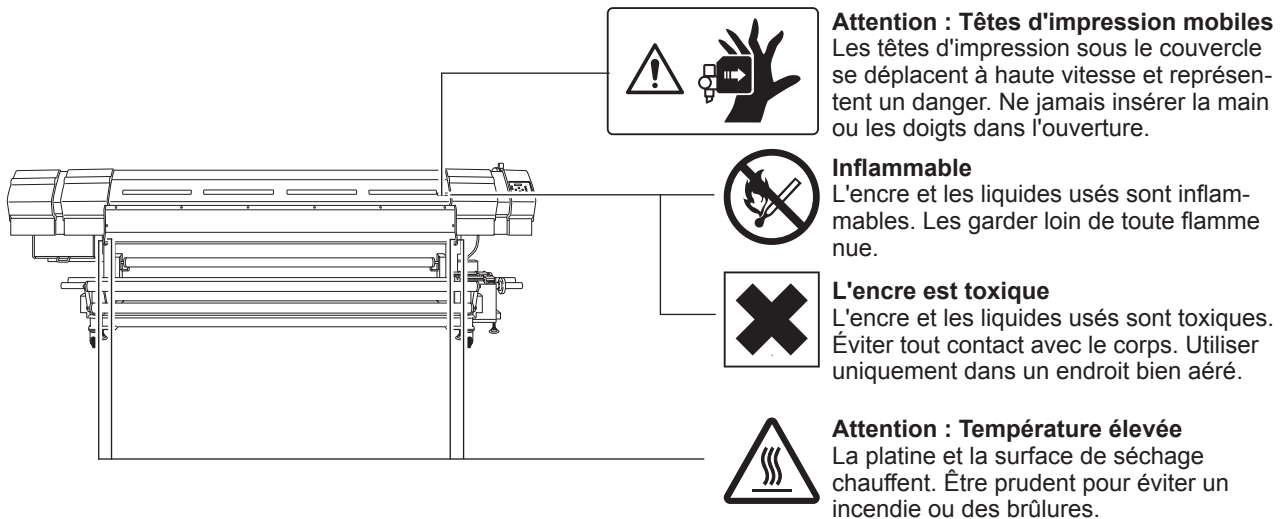

Inflammable

L'encre et les liquides usés sont inflammables. Les garder loin de toute flamme nue.



L'encre est toxique

L'encre et les liquides usés sont toxiques. Éviter tout contact avec le corps. Utiliser uniquement dans un endroit bien aéré.

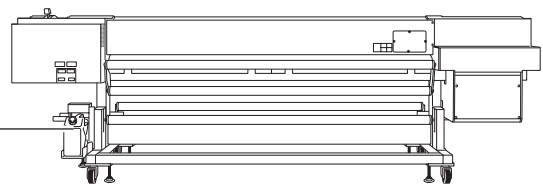

* Apposer uniquement sur le AJ-1000i.

Important Notes on Handling and Use

This machine is a precision device. To ensure the full performance of this machine, be sure to observe the following important points. Failure to observe these may not only result in loss of performance, but may also cause malfunction or breakdown.

Printer unit

This Machine Is a Precision Device

- Handle carefully, and never subject the machine to impact or excessive force.
- Never needlessly put your hand or fingers inside the cover, the ink-cartridge ports, or other internal areas of the machine.

Install in a Suitable Location

- Install in a location having the specified temperature and relative humidity.
- Install in a quiet, stable location offering good operating conditions.

Leave the Main Power on at All Times

- To keep the print heads from drying out, keep the main power switched on at all times, even when you're not using the machine. For more information about switching the power on and off, read this manual carefully and carry out the operation properly.

The Print Heads Are Delicate

- Never needlessly touch or allow media to scrape them. Failure to handle with care may cause damage.
- The print heads may be damaged if allowed to dry out. The machine prevents desiccation automatically, but improper operation may render this feature inoperative. Operate properly, as specified in this manual.
- Never allow the machine to stand with an ink cartridge removed. Remaining ink in the printer may harden and clog the print heads.
- The print heads are components that wear out. Periodic replacement is required, with the frequency of replacement depending on use.

This Machine Becomes Hot

- Never cover the ventilation holes with cloth, tape, or anything else.

When Moving the Machine

- Special preparations are required when moving the machine. Please check with your authorized Roland DG Corp. dealer ahead of time.

Ink cartridges

Ink Cartridges Come in Various Types

- Use a type that is compatible with the printer. Also, be sure to use only genuine items from Roland DG Corp.

Never Subject to Impact or Attempt to Disassemble

- Never drop or shake forcefully. The impact may rupture the internal pouch and cause the ink to leak.
- Never attempt to disassemble.
- Never attempt to refill the ink.
- If ink gets on your hands or clothing, wash it off as soon as possible. Removal may become difficult if allowed to stand.

Storage

- Store unopened in a well-ventilated location at a temperature of -20 to 40°C (-4 to 104°F).

Chapter 1

Introduction

1-1 Machine Features

This machine is a high-speed, grand-format printer compatible with media having a width of 104 inches (75 inches for the AJ-740i).

- It provides ample image quality for large outdoor signs and the like even in its fastest mode, demonstrating high practicality and productivity.
- The media take-up and feed systems and the media heating system are provided with the standard features that high-speed, high-volume printing requires.
- The machine is capable of high-density printing on outdoor-advertisement media, so it can achieve high weatherability even with the ink-jet system it uses.
- A self-cleaning feature performs automatic cleaning for the print heads, reducing the time and effort of daily maintenance. Other considerations enhance ease of use, including a preset feature that lets you save media-specific settings.

1-2 Part Names and Functions

Printer Unit

■AJ-1000i

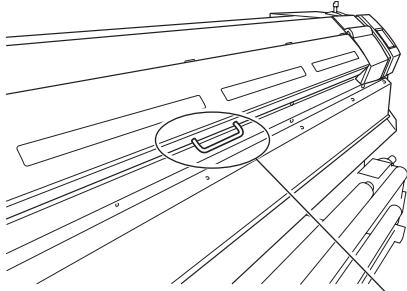

■AJ-740i

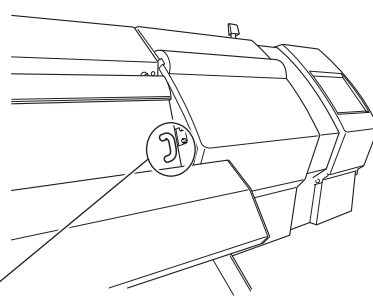

Handle

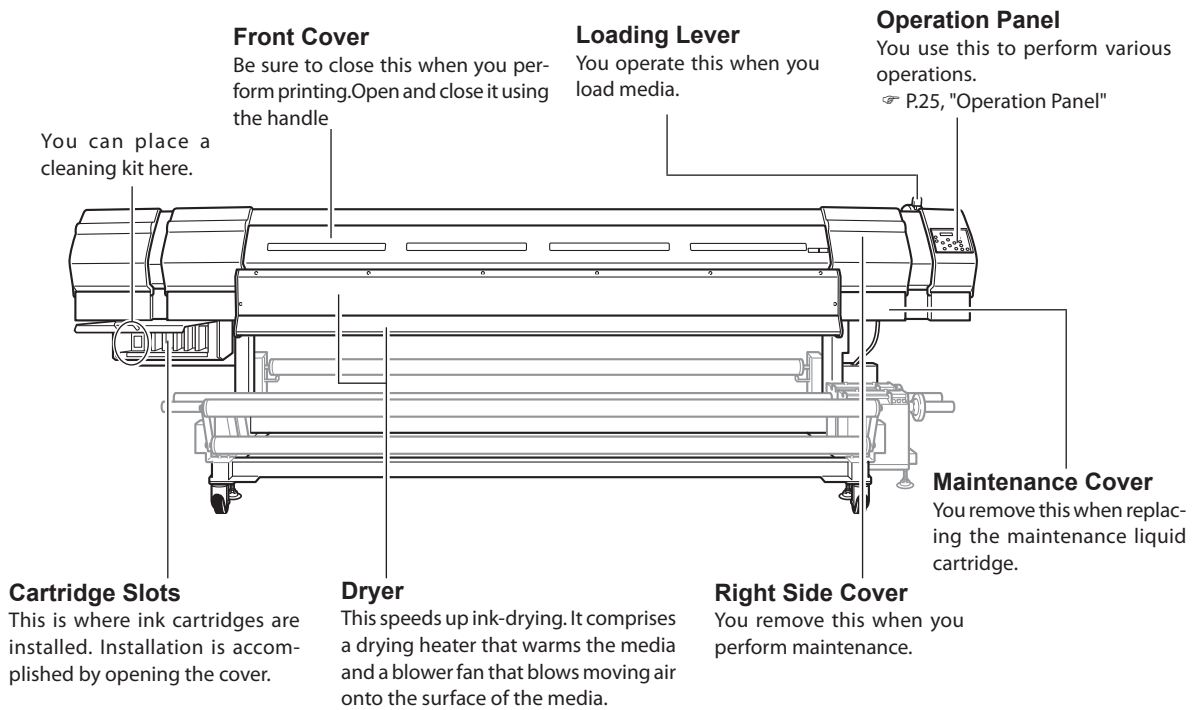

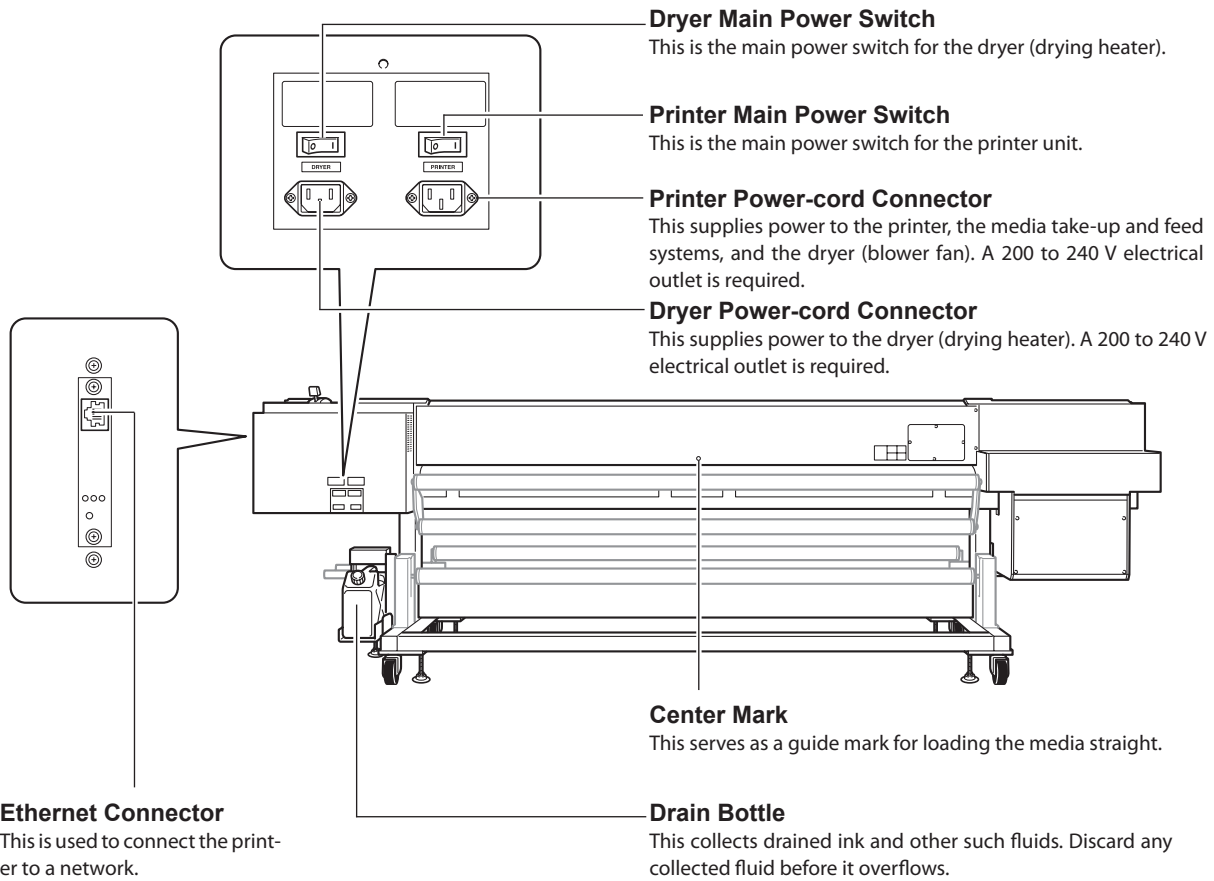

Platen

This is the path over which the media passes. A suction fan that keeps the media from coming loose and a preheater and print heater that help fix the ink are built in.

Media Clamps

These keep the media from coming loose and prevent fuzz on the cut edge of the media from touching the print heads.

Pinch Rollers

These clamp the media when the loading lever is pulled back toward you.

Grit Rollers

These rollers feed out media toward the front of the machine.

Knife Guide

The media can be cut off with a straight edge by inserting a retractable knife into this groove.

Print-head Carriage

The print heads are inside this.

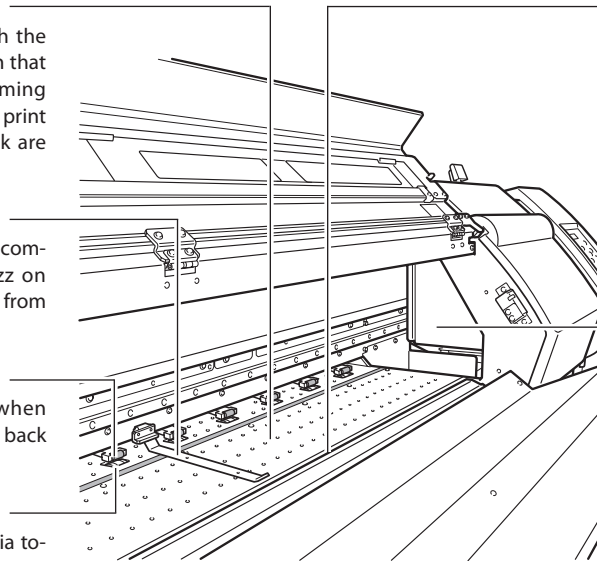



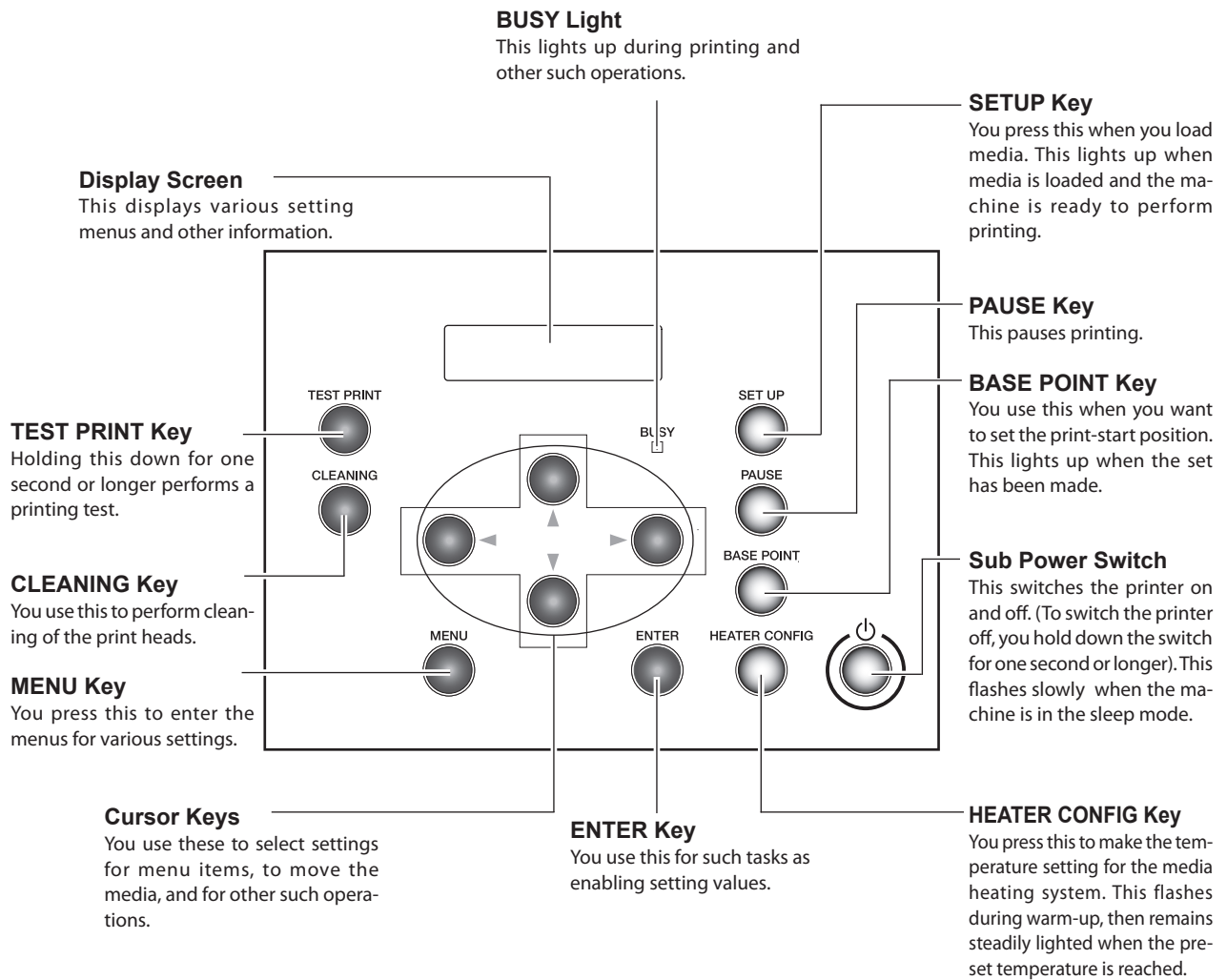





Operation Panel



Panel Notation

In this document, the keys and lights on the control panel are indicated by the following images.

-  SETUP Key
-  MENU Key
-  HEATER CONFIG Key
-  ENTER Key
-  Cursor Keys
-  PAUSE Key
-  TEST PRINT Key
-  CLEANING Key
-  BASE POINT Key

Media Take-up and Feed Systems

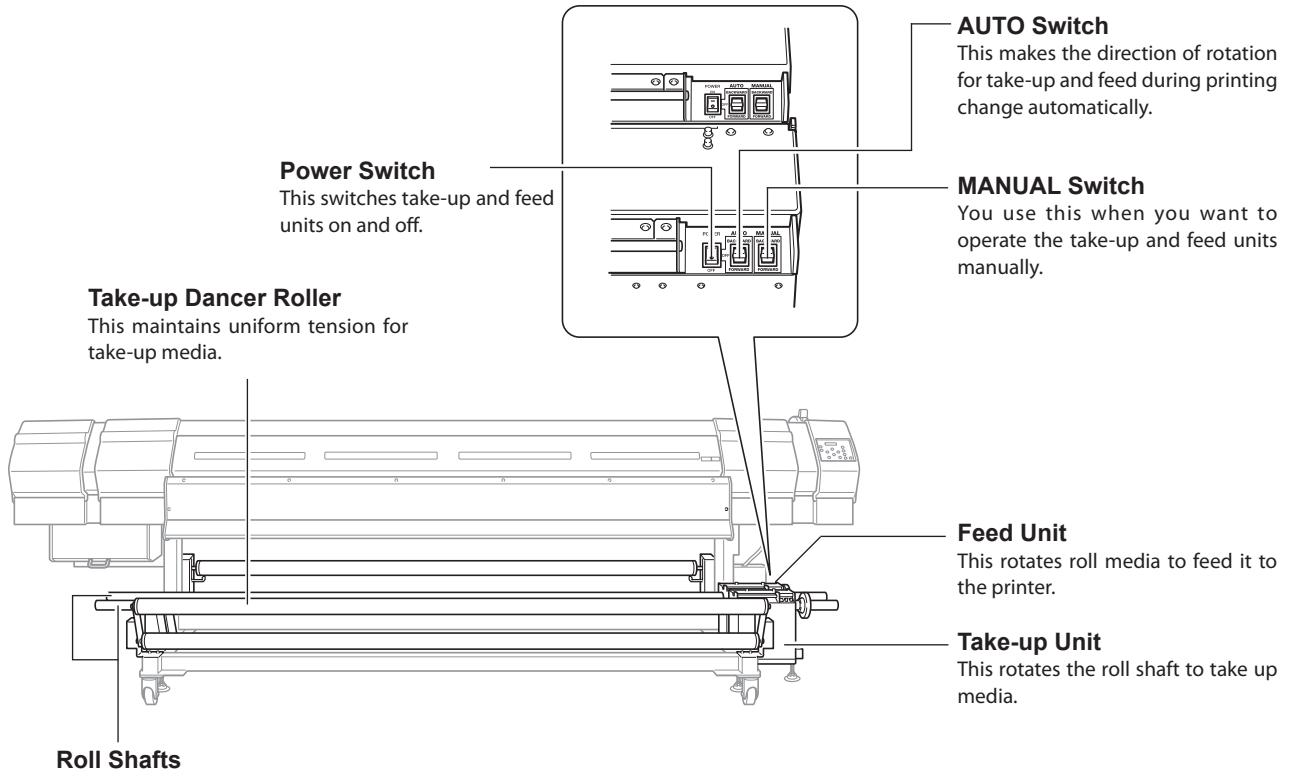

■AJ-1000i

Guide Roller

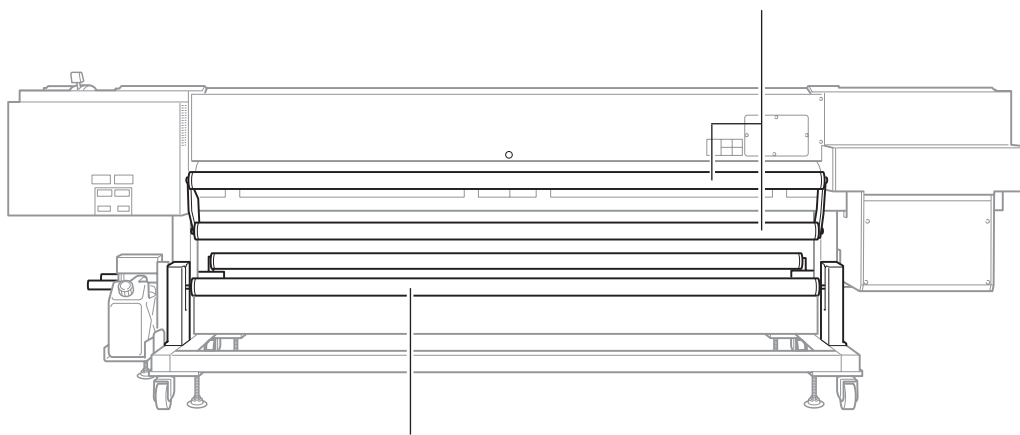

Feed Dancer Roller
This maintains uniform tension for the feed media.

■AJ-740i

Guide Roller

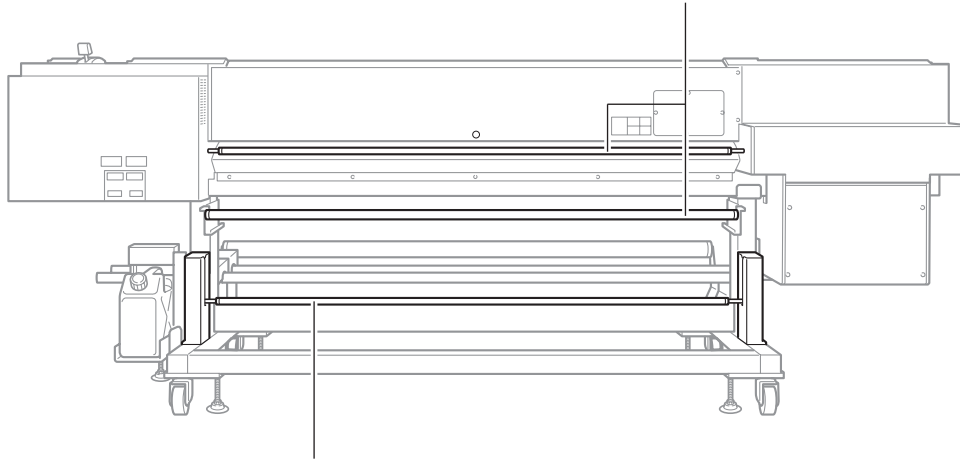

Feed Dancer Roller

This maintains uniform tension for the feed media.

Chapter 2

Basic Operation

2-1 Switching the Power On and Off

Switching the Power On and Off

This machine has four power switches. You switch on all four when using the machine.

When you finish printing, you turn off switches 3 and 4 as required. You also flip down the loading lever to the rear of the machine.

Leave the two main power switches (1 and 2) on at all times, never switching either one off. (The machine monitors the print heads for dryness and automatically performs cleaning while switched on.)

⚠️ WARNING When printing is not being performed, remove any loaded media or switch off the power.

The continued application of heat at a single location may cause the release of toxic gases from the media or pose a fire hazard.

Be sure to leave switched on at all times.

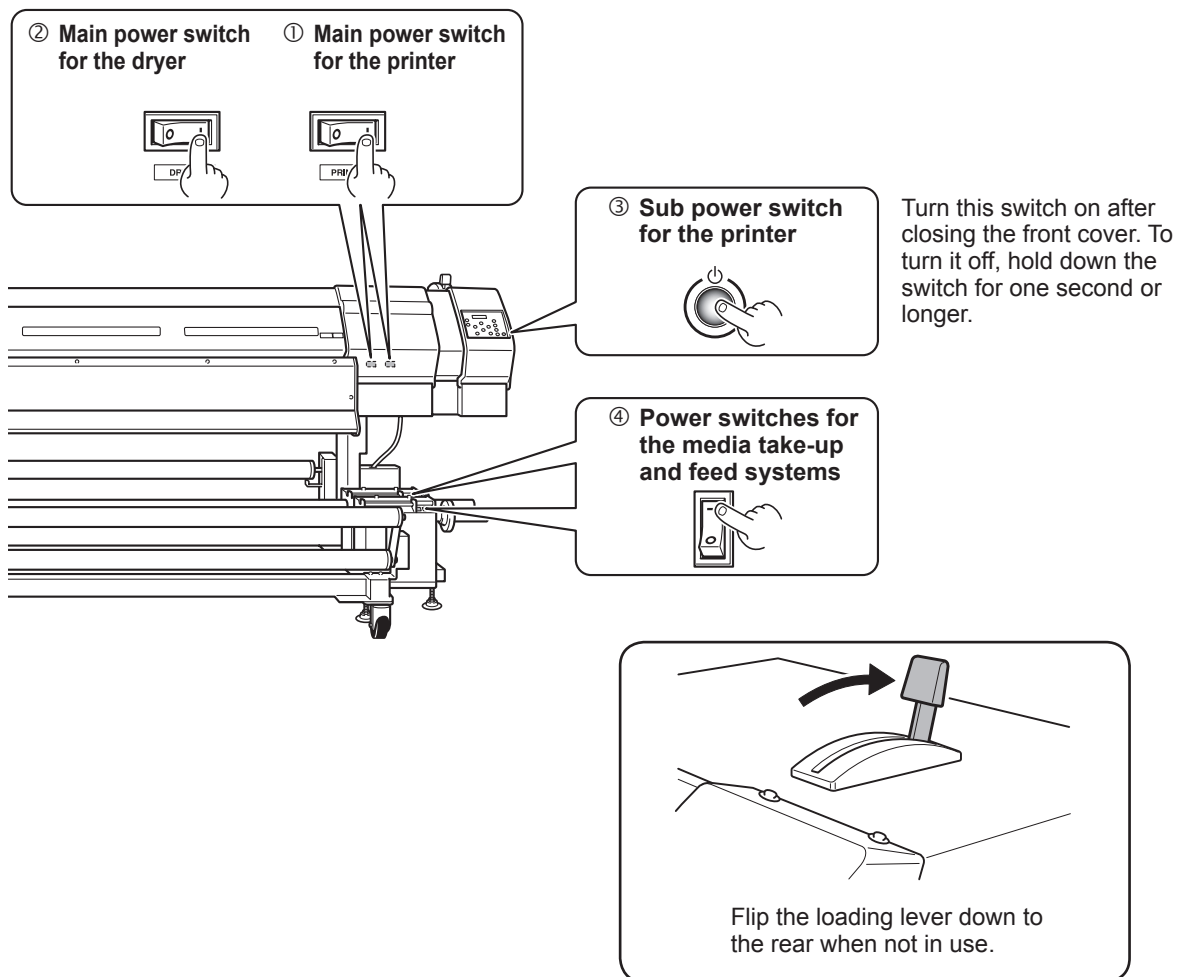

Important Note on Switching Off the Power

Never switch off the printer's main power or unplug the power cord suddenly while operation is in progress. Doing so may damage the print heads. To turn off the power, switch off only the sub power (except when you're performing tasks such as moving the machine).

If the main power is accidentally switched off, immediately turn the main power and sub power back on.

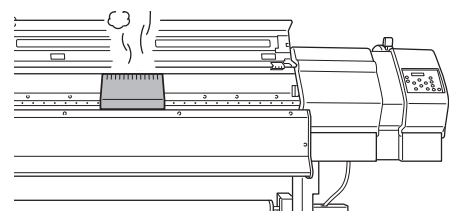

The Power-saving Feature

This machine is provided with a power-saving feature that switches to a low-power "sleep mode" when a fixed interval passes with no operation. The factory default for the time after which the machine switches to the sleep mode is 30 minutes. You can change the setting for the time of the shift to the sleep mode. You can also switch off the power-saving feature.

☞ P.93, "Setting the Interval until Activation of the Sleep Mode"

☞ P.94, "Deactivating the Sleep Mode"

When the machine is in the sleep mode, the sub power switch flashes slowly and the media heating system stops. Using the control panel or performing operations such as sending printing data from the computer (when media is loaded) restore the machine to its normal mode.

To reduce power consumption and prevent problems such as overheating, we recommend leaving the power-saving feature on and setting the activation time for the sleep mode to 30 minutes or less.

2-2 Loading and Cutting Off Media

How to Load Media

- ⚠️WARNING** When loading or moving roll media, use lifting equipment, and exercise care to prevent falls. Attempting manual lifting of heavy media that taxes your strength may cause physical injury. Also, if dropped, such items may cause injury.
- ⚠️WARNING** Never load media that weighs more than 100 kg (220 lb.) . The machine may fail to withstand the weight and tip over or cause the media to fall.
- ⚠️CAUTION** Be sure to perform operations as specified by these instructions, and never touch any area not specified in the instructions. Sudden movement of the machine may cause injury.

Read This First

To achieve maximum performance from the machine, the media must be loaded correctly. Incorrect loading may result in poor printing results or cause the media to become crooked.

☞ P.109, "Attractive Printing Is Impossible," p.112, "The Media Cannot Be Taken Up Smoothly," p.113, "Media Wrinkles or Shrinks, or Feed Is Unstable"

Correctly Loaded Media

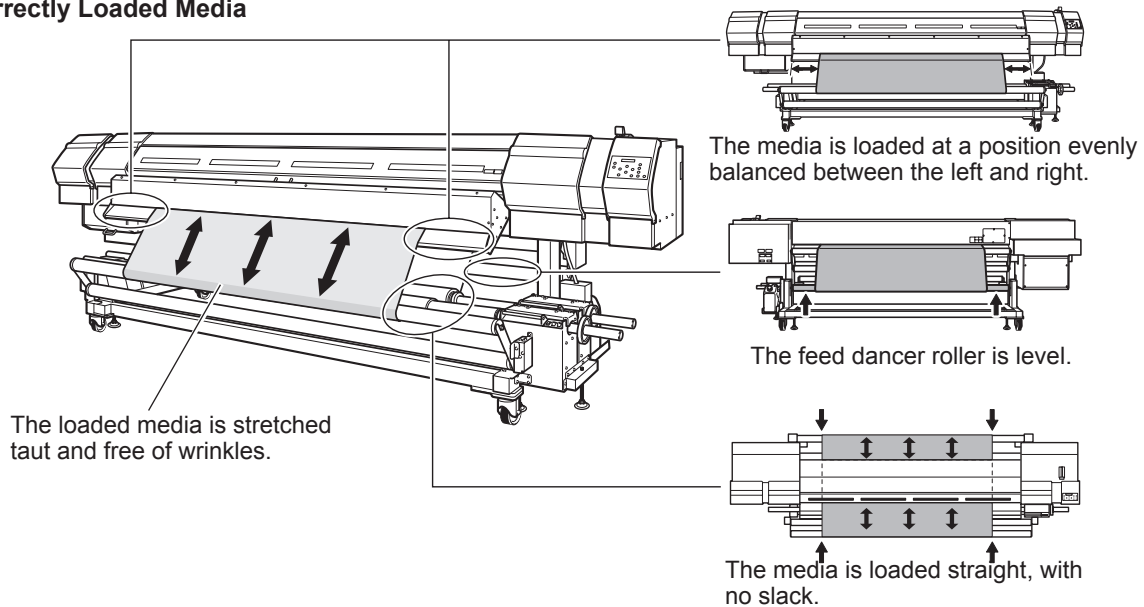

In order to load media correctly as shown in the figure, be sure to observe the following:

Use a media gauge.

When mounting the roll shaft, be sure to use the included media gauge. This is for loading media so that it is positioned evenly on the left and right.

You also use the media gauge when making sure that the left and right edges each lie on a straight line.

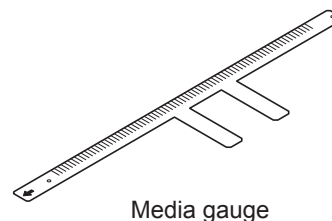

Narrow-width media cannot be used.

Never use media less than 1,220 mm (48 inches) in width. Doing so may result in incorrect media movement, or malfunction or damage to the machine.

For roll media, use reinforcement pipes.

When using roll media, make use of the reinforcement pipes. They reduce sagging of the roll media.

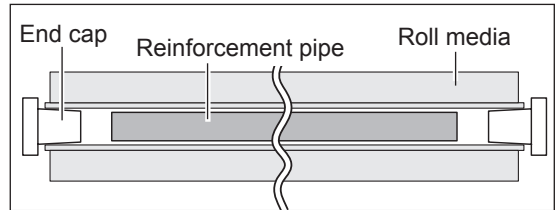

When passing media through the printer, feed the media through while pressing down on it at the center.

When passing media through the printer, be sure to press down on the media at the center with two hands and slowly push (or pull) the media through. This is done in order to load the media so that it lies straight with respect to the direction of feed.

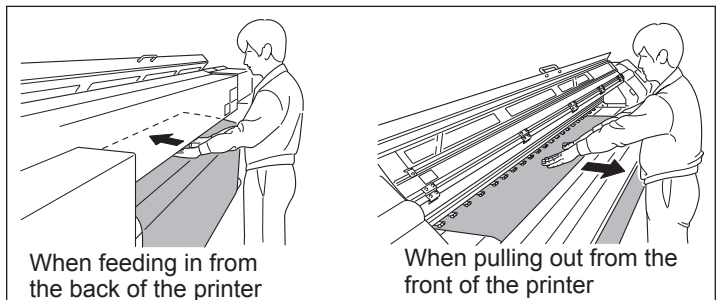

If the surface of the media is slippery, use rubber finger caps or the like to maintain a firm grip and keep the media from slipping out of your hands.

Never pull the left and right edges of the media. Doing so may cause the media to be pulled out at an angle, making it impossible to load the media so it lies straight. Carrying out printing when the media is loaded at an angle, as shown in the figure, may not only cause poor printing results, but may cause the media to become crooked or jam.

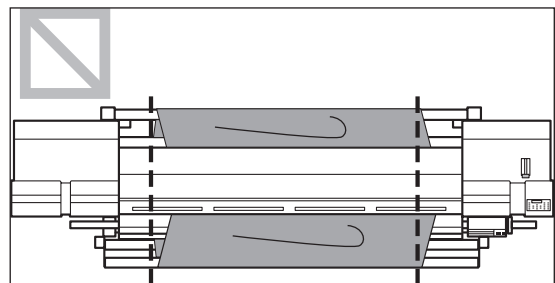

Never feed the media through using the media take-up and feed systems.

When loading media, never feed the media through using the MANUAL switch on the media take-up and feed systems. Doing so may cause the media to become crooked or jam.

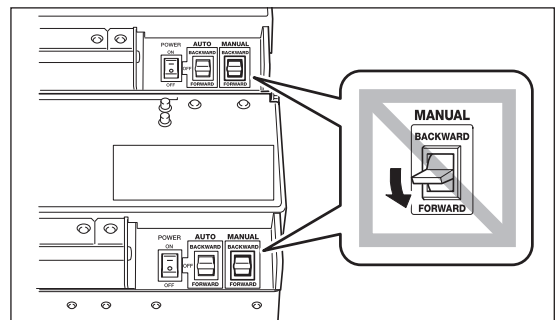

1. Mount the media and the paper tube on the roll shaft.

① Load the media onto the roll shaft.

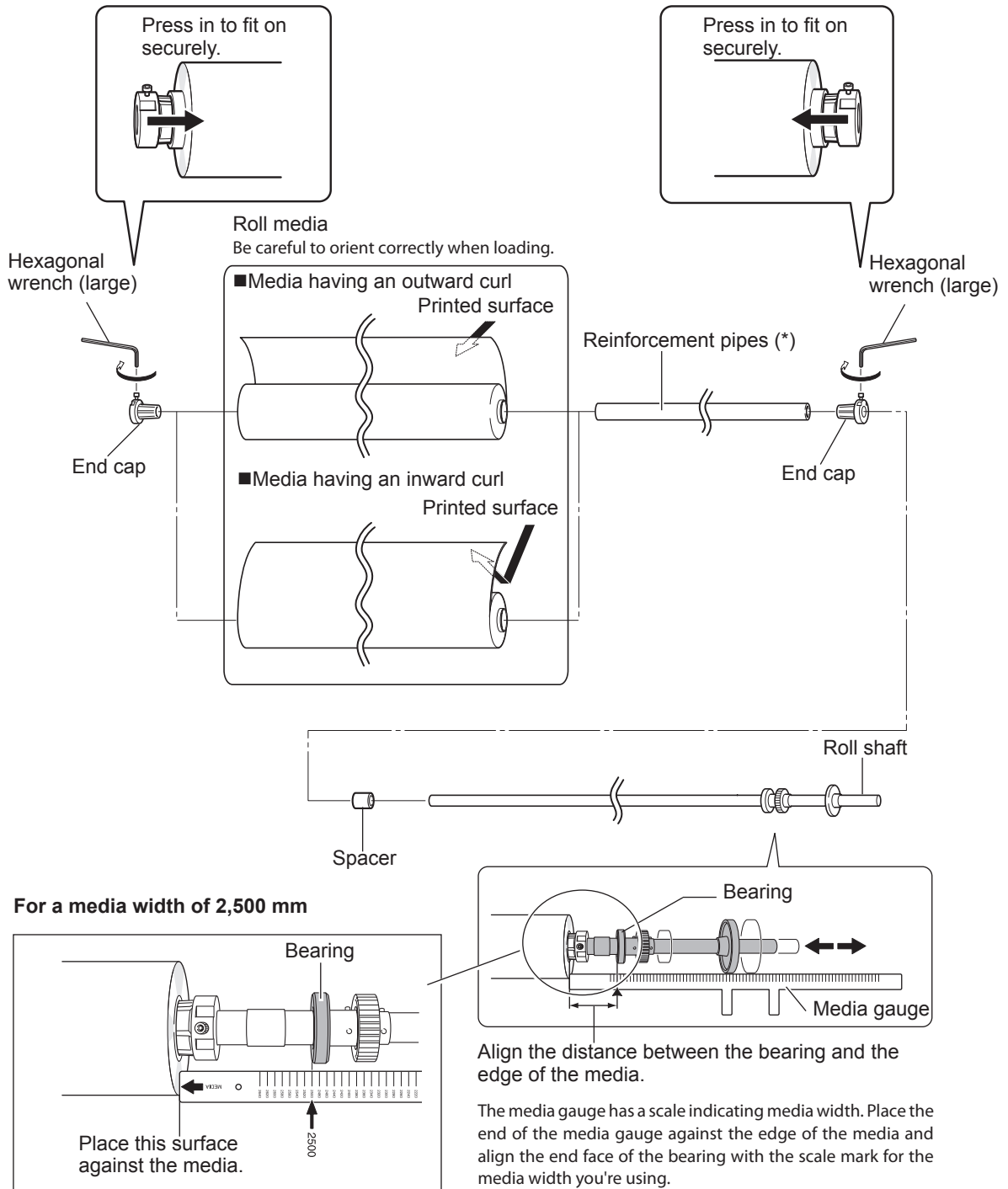

* The type and number of reinforcement pipes used are as follows.

AJ-740i:

Use one short reinforcement pipe.

AJ-1000i:

For roll media measuring less than 2,210 millimeters (87 inches), use one short reinforcement pipe.

For roll media measuring 2,210 millimeters (87 inches) or more, use either two short reinforcement pipes or one long reinforcement pipe.

2 Mount the roll shaft in the paper tube.

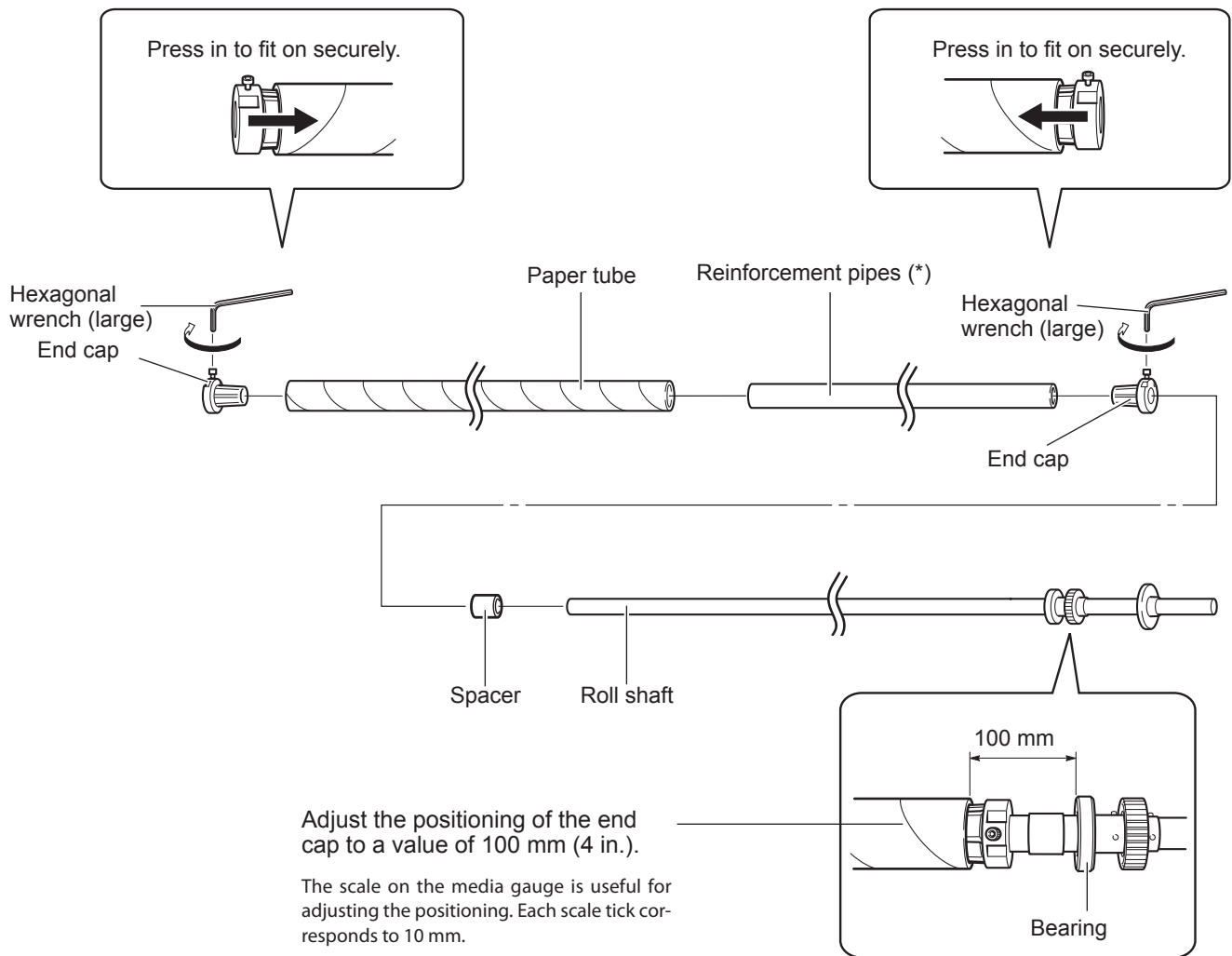

* The type and number of reinforcement pipes used are as follows.

AJ-740i:

Use one short reinforcement pipe.

AJ-1000i:

For a paper tube measuring less than 2,210 millimeters (87 inches), use one short reinforcement pipe.

For a paper tube measuring 2,210 millimeters (87 inches) or more, use either two short reinforcement pipes or one long reinforcement pipe.

Never overly loosen the screws for the end caps.

When an end cap screw is loosened completely, it stops turning. Never apply more force beyond that point. Attempting to turn the screw with undue force may damage the component securing the screw, making return to the original state impossible.

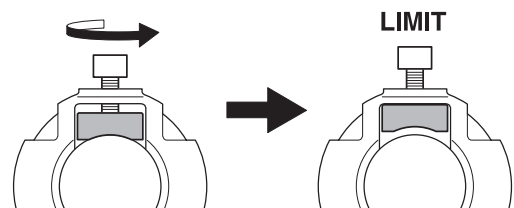

2. Mount the media and paper tube on the take-up and feed units.

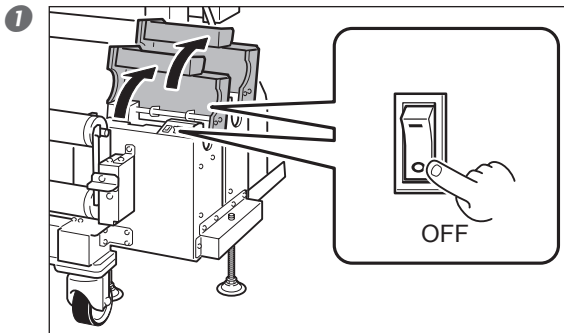

Switch off the take-up and feed units and open the covers.

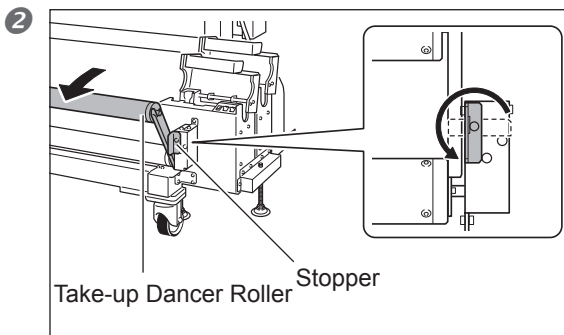

Release the stopper and flip the take-up dancer roller back toward you.

3 Mount the roll shaft.

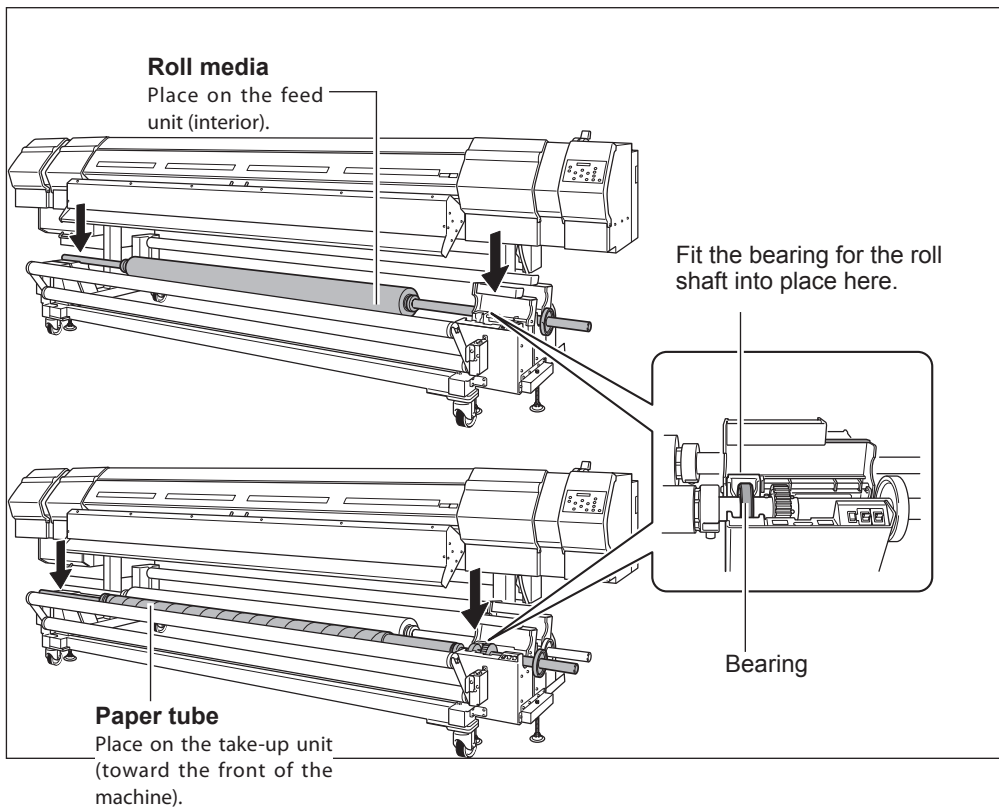

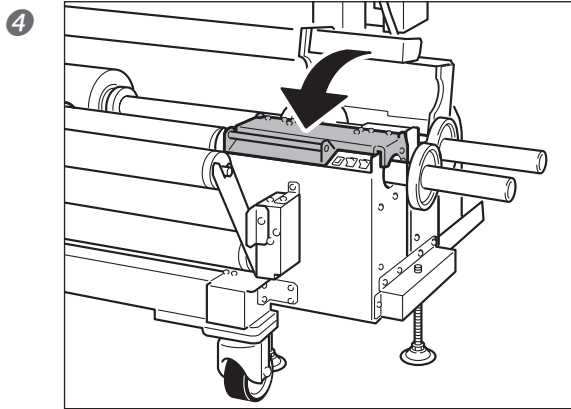

Close the cover for the take-up unit.
Leave the cover for the feed unit open.

3. To load the media straight, make guide marks for positioning.

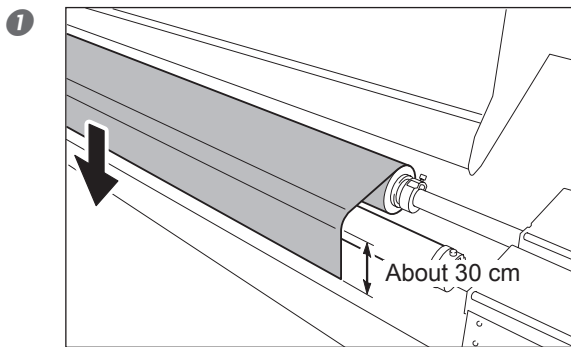

Pull out the media back toward you and let it hang down, with no slack in the portion above the paper tube.
Hold near the center and pull out straight.

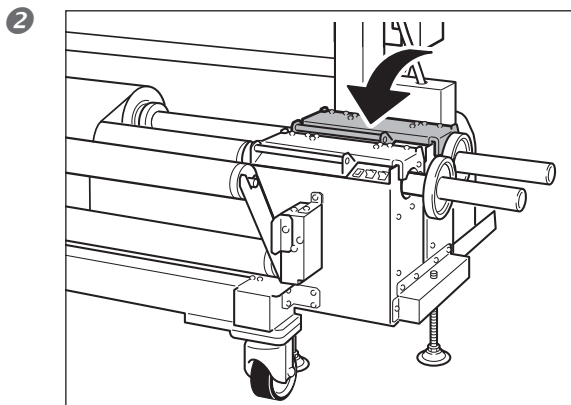

Close the cover of the feed unit.
This keeps the media from slipping off.

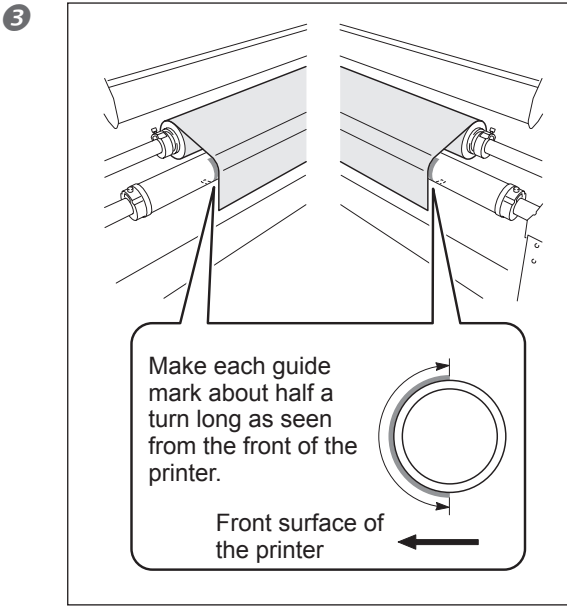

Make guide marks on the paper tube for the left and right edges of the media.

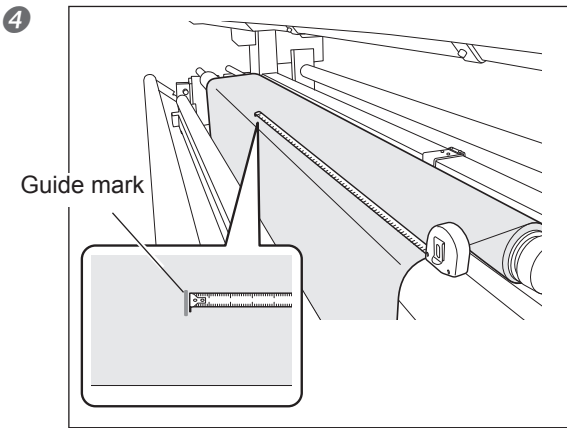

On the media, apply a guide mark indicating the center of the media width.

4. Pass the media through the printer and feed it out as far as the platen.

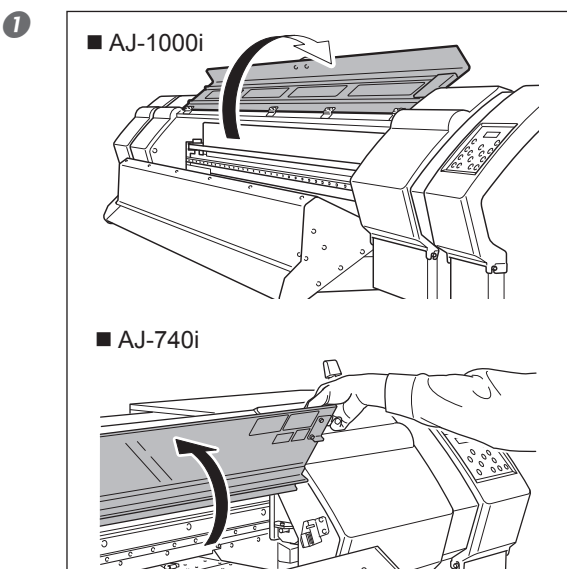

Open the front cover.
Grasp the handle to open.

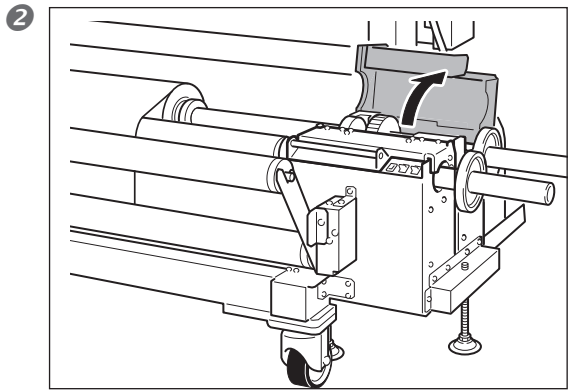

Open the cover for the feed unit.

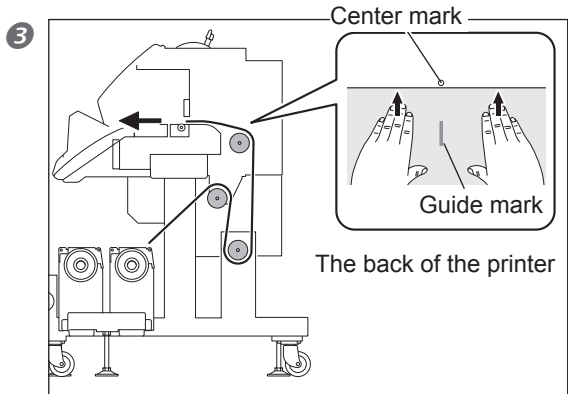

Feed out the media, pass it between the dancer rollers and guide rollers, and insert the end of the media into the back of the printer.

Work from the back of the printer.

Slowly pull out the media, keeping it straight, and make sure the guide mark for the center of the media width passes under the center mark.

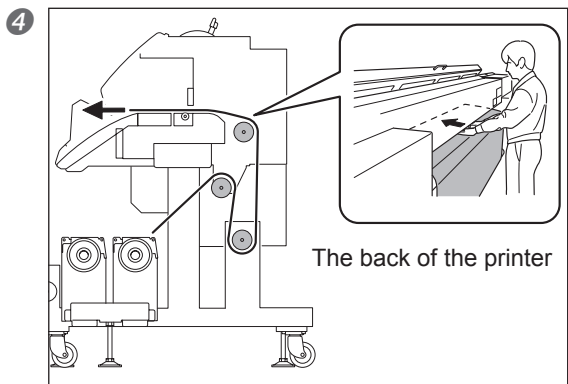

Bring the end of the media as far as the platen.

While being careful to ensure that the media is free of slackness or wrinkling, push it out straight and positioned evenly on the left and right.

☞ P.32, "Read This First"

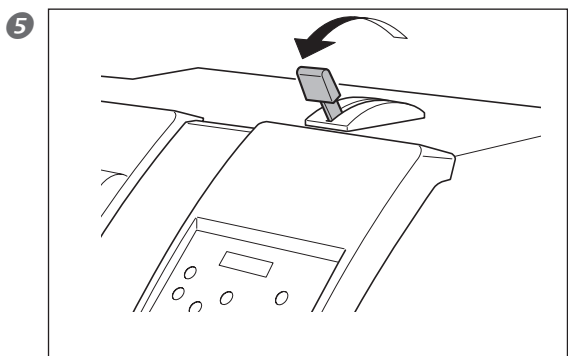

Pull the loading lever.

This keeps the media from slipping off.

5. Pull out the media.

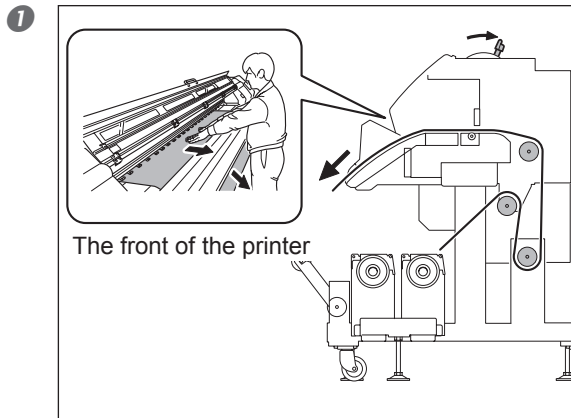

- ① Go to the front of the printer.
- ② While holding down the media by hand to keep it from slipping out of place, flip the loading lever to the rear.
- ③ Slowly pull the media out straight until it reaches the area below the blower fan.

While being careful to ensure that the media is free of slackness or wrinkling, pull it out straight and positioned evenly on the left and right.

Never hold the media by its leading edge or by its left or right edge when pulling it out.

☞ P.32, "Read This First"

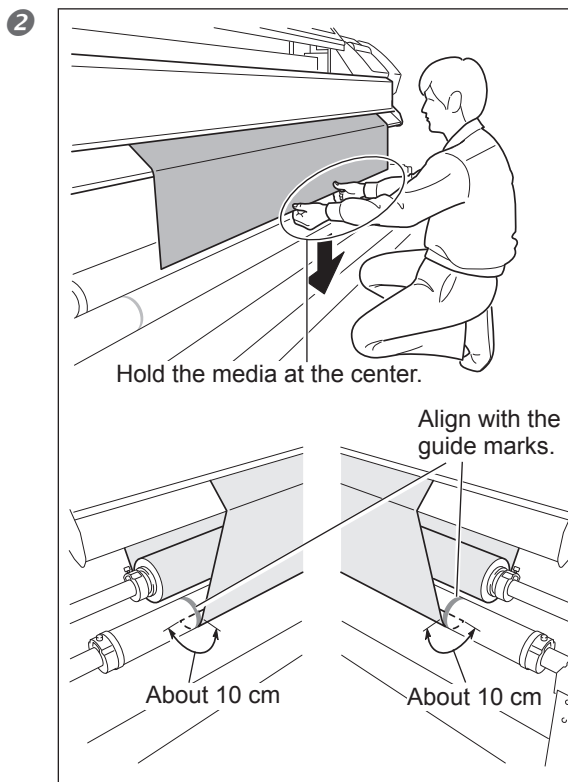

Grasp the leading edge of the media at the center and slowly pull out the media straight until it reaches a position about even with the paper tube.

After pulling out the media, align the left and right edges with the guide marks on the paper tube while holding the media stretched taut to keep it from wrinkling.

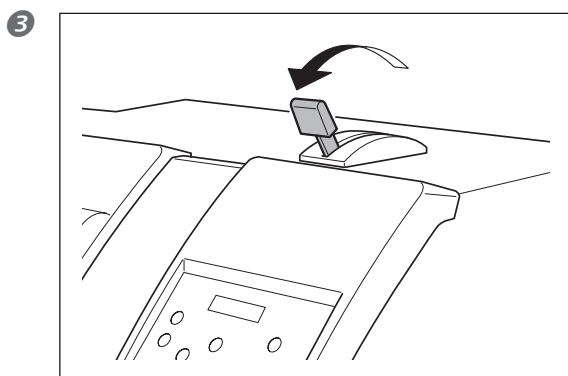

Pull the loading lever.

This keeps the media from slipping out of position.

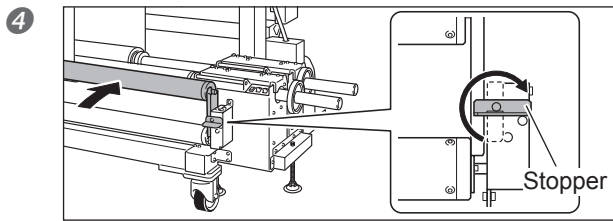

Move the take-up dancer roller inwards and secure it in place with the stopper.

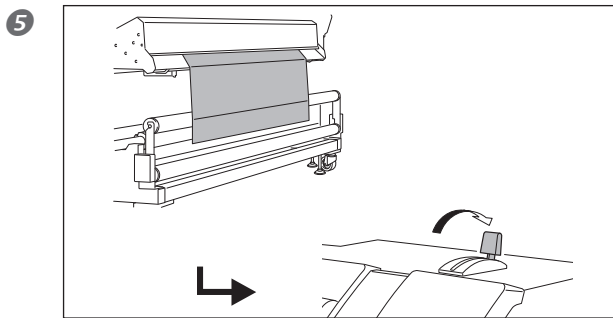

Let the media hang down to the front of the take-up dancer roller and move the loading lever toward the rear.

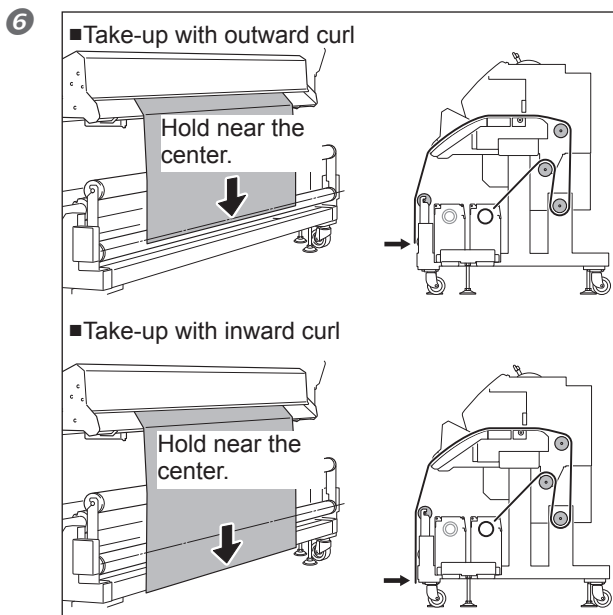

Slowly pull the media out straight until it reaches the location shown in the figure. Never grasp the left and right edges when pulling out.

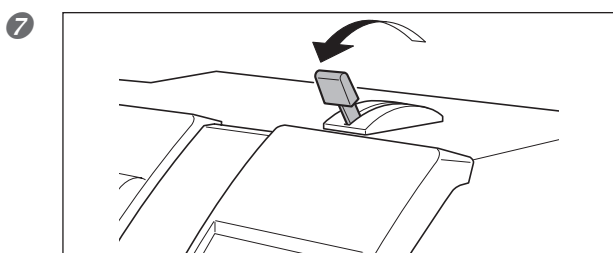

Pull back the loading lever to secure the media in place.

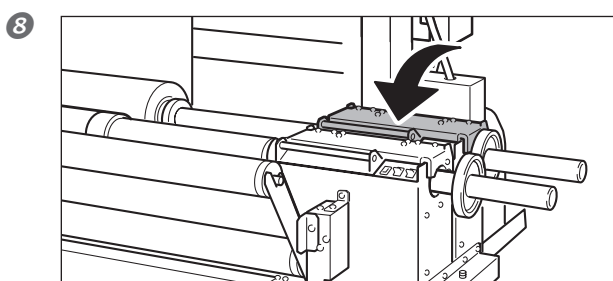

Close the cover for the feed unit.

6. Prepare the media for take-up on the paper tube.

- ① Use adhesive tape to fasten the media securely to the paper tube. Apply adhesive tape at about five evenly spaced locations.
 - ① Secure the center of the media in place while keeping the media stretched taut to keep it free of slack.
 - ② While pulling the media, working from the center toward the outer sides, secure the media in place at intermediate locations between the center and the left and right edges.
 - ③ Line up the left and right edges of the media with the guide marks on the paper tube and secure the media in place.

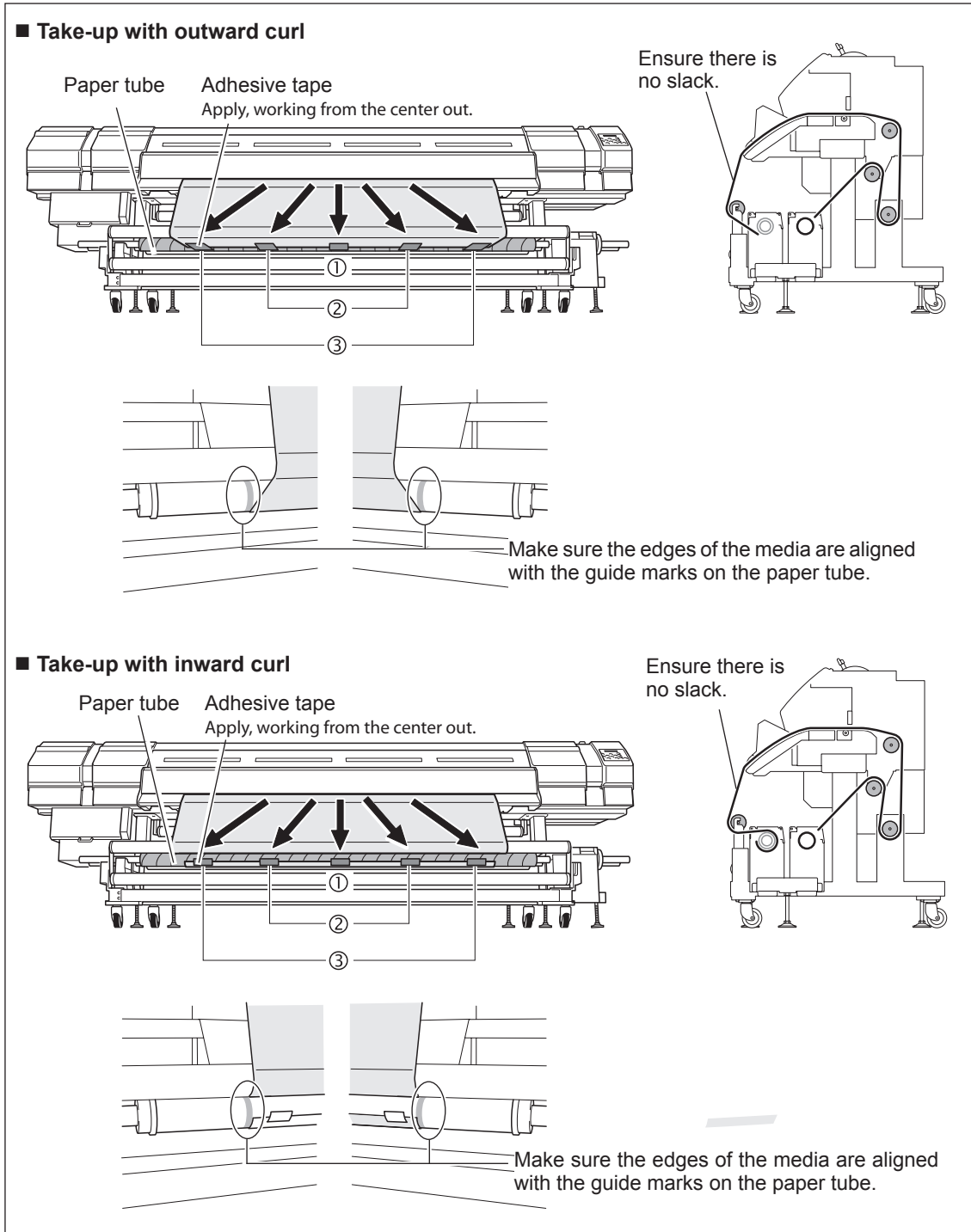

- 2 Using the media gauge, make sure the left and right edges of the media on the take-up and feed sides are aligned.

This is done in order to make sure the media is loaded so that it lies straight.

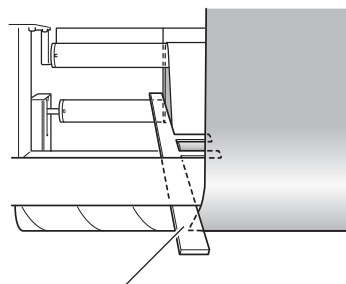
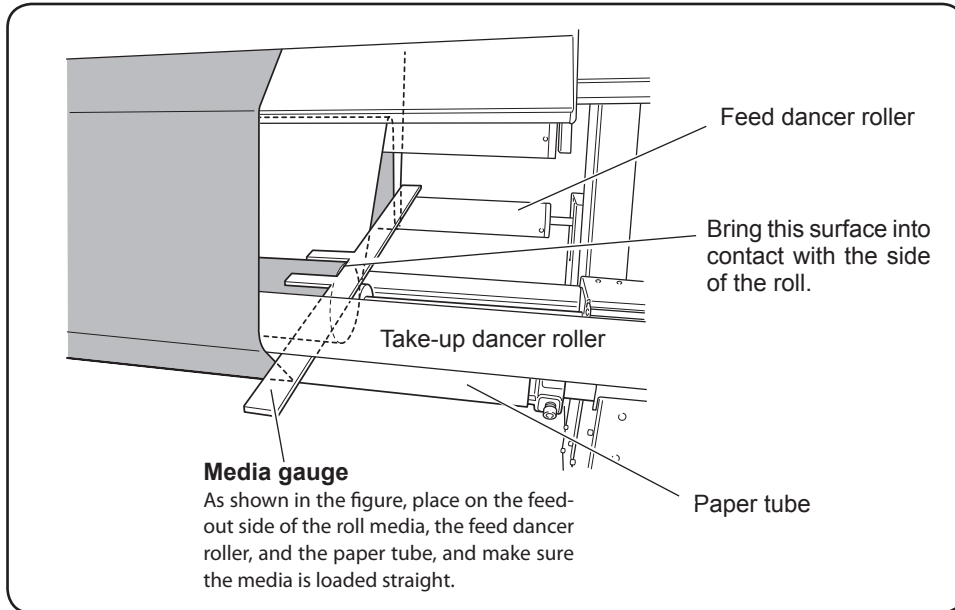

Orient with the scale at the bottom.

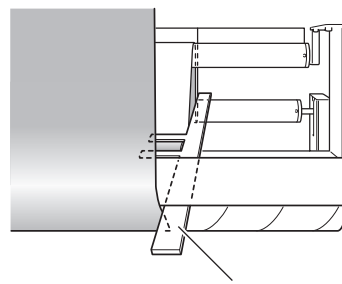

Orient with the scale at the top.

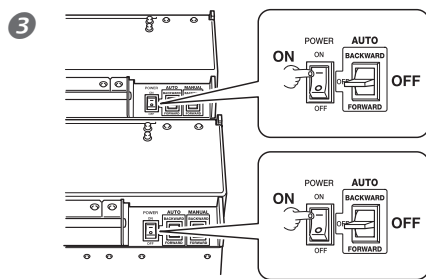

Set the orientation for automatic feed and automatic take-up.

- 1 Set the AUTO switch off.
- 2 Switch on the power.

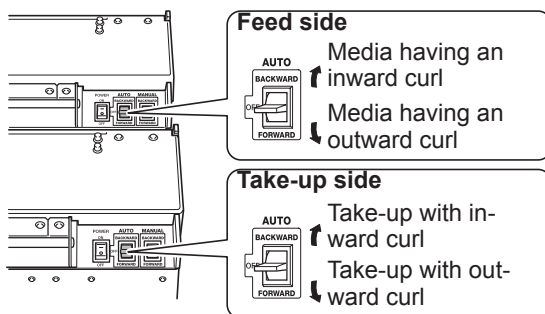

- 3 Set the AUTO switches for the feed and take-up units.

7. Install the media clamps.

When performing printing, be sure to attach the media clamps .

Performing printing, without attaching the media clamps may cause the media to catch on the print heads or result in damage to the print heads.

however, never use the media clamps when the [HEAD HEIGHT] menu item is set to "LOW."

☞ P.82, "Adjusting Head Height to Match Media Thickness"

The media clamps are magnetic.

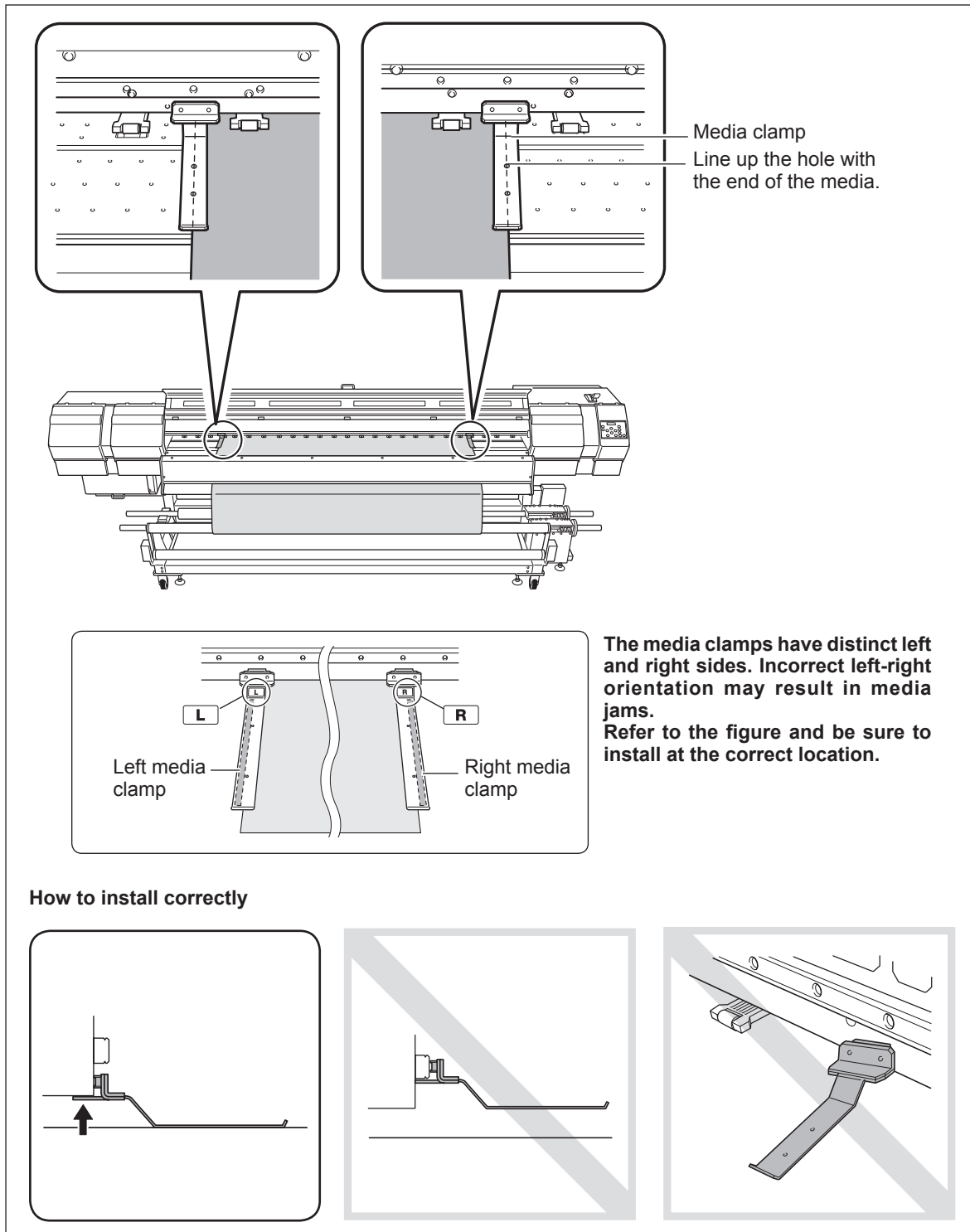

8. Take up the media onto the paper tube.

1

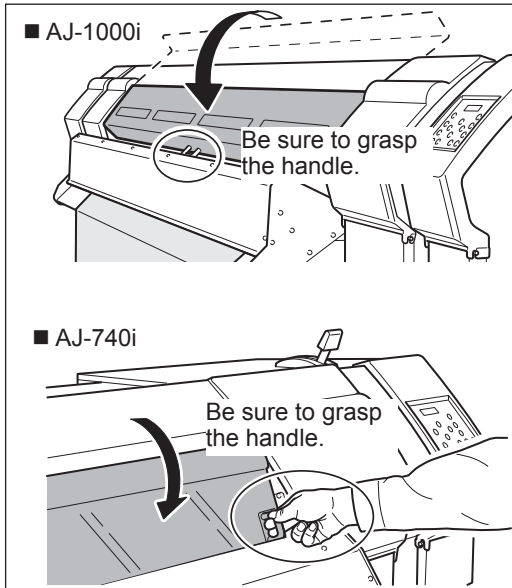

Close the front cover.

2

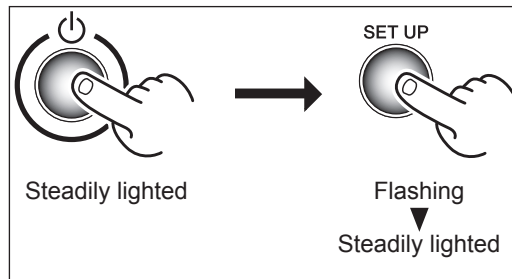

- ① Turn on the sub power switch.
- ② When the sub power switch lights up, press **SET UP**.
The key flashes, then remains steadily lit.

After **SET UP** lights up, proceed in the sequence indicated below. If the key doesn't light up, refer to the following.

☞ P.108, "The Machine Doesn't Run"

3

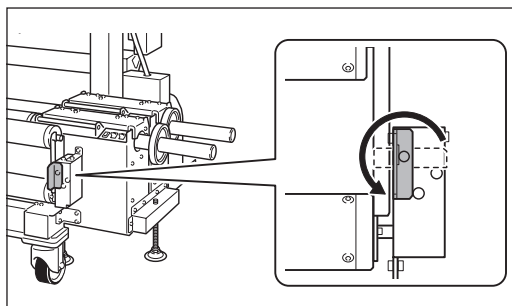

Release the stopper for the take-up dancer roller.

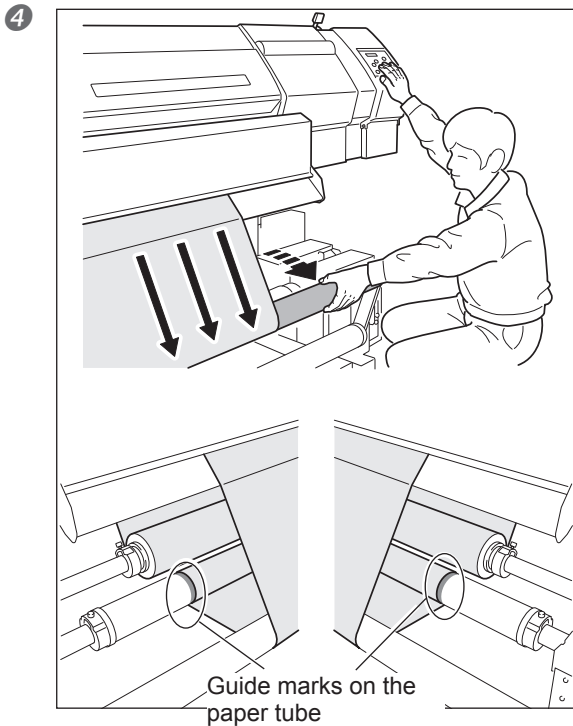

While supporting the take-up dancer roller with your hand, use  to feed out the media and take it up on the paper tube a little at a time.

Take up the media for one turn or more.

Continue to support the dancer roller with your hand until the take-up unit starts to take up the media. While keeping the dancer roller flipped back toward you to keep the media from becoming slack, feed the media a little at a time.

When the take-up unit begins to take up the media, release the dancer roller and feed the media a little at a time.

After taking up the media for one turn or more, check to make sure the two edges of the media are aligned with the guide marks on the paper tube.

When you begin take-up, take care to ensure that the end of the media does not become rolled or creased.

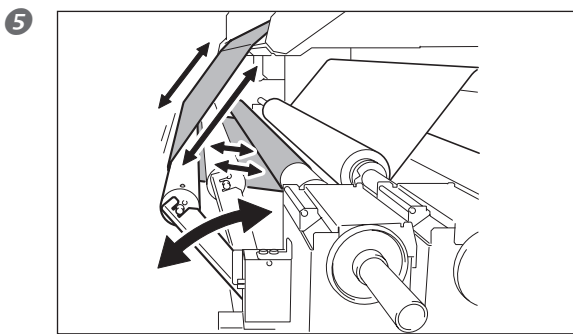

Move the take-up dancer roller forward and backward to stretch the media taut.

If the media is not stretched taut, it may become crooked or wrinkle.

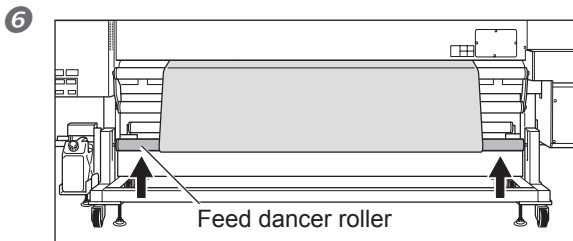



Go around to the back of the printer and make sure the feed dancer roller is level.

If it is at a large slant, the media may become crooked or wrinkle.

Never pull the media with excessive force.

Never attempt any operation that pulls the media with excessive force, like the ones shown below. Doing so may activate a protective feature and result in an error.

- Never operate the MANUAL switch for the media take-up and feed systems when the loading lever has been pulled back.
- Never use  to feed the media in reverse.
- Never move the media with  continuously for more than one minute.

⚠ CAUTION

Never needlessly touch the dancer rollers.

Sudden movement of the media take-up or feed system may cause injury.

How to Cut Off Media

CAUTION

The cutter knife used here is sharp and poses a hazard. Carry out operations with caution to avoid injury.

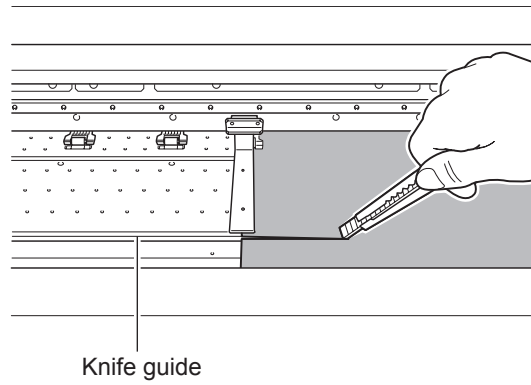

Cut off the media along the knife guide, using a retractable knife or the like.

2-3 Settings of the Media Heating System

What Is the Media Heating System?

This machine is equipped with a media heating system that warms the media. You use this mainly to improve ink adhesion and dry the ink.

The media heating system is composed of the three devices shown in the figure below.

Preheater

This device warms the media before printing.

Print heater

This device is used mainly to improve ink adhesion.

Dryer (drying heater and blower fan)

You use this to speed up drying of the ink.

Drying heater

This warms the media after printing.

Blower fan

This blows moving air onto the surface of the media after printing.

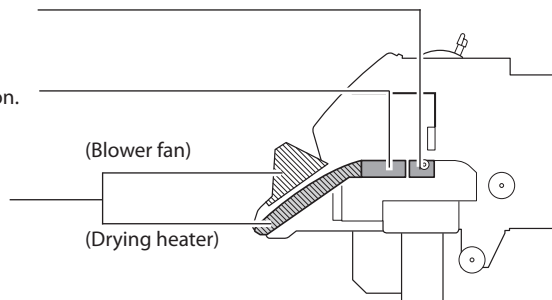

⚠️ WARNING

Caution: high temperatures.

The platen and dryer become hot. Exercise caution to avoid fire or burns.

⚠️ WARNING

Remove any loaded media or switch off the sub power when printing is not being performed.

The continued application of heat at a single location may cause fire or produce toxic gases.

⚠️ WARNING

Never use media that cannot withstand the heat.

Doing so may result in fire or the release of toxic gases, or may degrade the media.

⚠️ WARNING

Never use the platen or dryer for any purpose for which they are not intended, such as to dry clothing.

Doing so may cause overheating, resulting in fire or accident.

Making the Temperature Setting for the Media Heating System

Procedure

1 PRE 45 PRINT 45
DRY 50

Press **HEATER CONF.**

The present temperature is displayed.

2 PRINT 45 ◀▶
45 ▶ 45 ◀▶

Press **HEATER CONF.** a second time.

Use **◀ ▶** to select the unit.

3 PRINT 45 ◀▶
40 ▶ 40 ◀▶

Use **▲ ▼** to make the setting.

Press **ENTER** to enable the setting.

4 W 2600 mm
SETUP SHEET

Press **MENU**.

Press **◀** to go back to the original screen.

By default, simply switching on the power does not make the machine warm up to the preset temperature. Pressing **SET UP** to make the light come on makes them to warm up to the preset temperature.

General Guide for the Preset Temperatures

The optimal temperature for the media heating system varies according to such factors as the type of media and differences in the print mode. Use the following as a general guide and adjust accordingly.

General Guide for Adjustment

Preheater

Set this to a temperature that is the same as or lower than the temperature of the print heater.

You use the preheater mainly to heat media gradually. This is because media becomes more likely to shrink or wrinkle if heated suddenly.

Print heater

You use this mainly to improve ink adhesion and inhibit smudging.

If the ink forms lumps or smudges, raise the temperature. Note, however, that a temperature that is too high may degrade the media or cause it to wrinkle.

Dryer

When ink drying is poor, raise the temperature. Note, however, that a temperature that is too high may degrade the media or cause it to wrinkle.

The relationship between the print mode and temperature

If smudging or poor drying occur even after raising the temperature, try using a print mode offering higher image quality. Conversely, when you want to use a faster print mode, raise the temperature.

Amount of ink

When you change the amount of ink using the settings for your RIP program, adjusting this may yield better results. If problems such as smudging persist even after raising the temperature, try reducing the amount of ink.

Examples of Preset Temperatures

Media	Temperature
Type: Scrim banner (PVC) Thickness: 300 to 400 μm (12 to 16 mil)	Preheater: 40°C (104°F) Print heater: 40°C (104°F) Dryer: 50°C (122°F)
Type: Marking film (PVC, with adhesive) Thickness: 60 to 100 μm (2.5 to 4 mil, not including backing paper)	Preheater: 35°C (90°F) Print heater: 35°C (90°F) Dryer: 45°C (112°F)

- These are only rough estimates. Make adjustments to match the media you're using.
- Using the media heating system does not necessarily make it possible to apply ink to every kind of media. Be sure to test in advance.
- Results may vary greatly depending on the print mode and other factors. Make settings suited to the media.
- When suggested settings for temperature, print mode, and other values are given, use the suggested settings.

2-4 Starting Printing

Getting Ready to Receive Data from a Computer

When you have finished loading media and making the temperature settings for the media heating system, then follow the steps below. This procedure enables the machine to receive data from the computer and perform printing.

Procedure

- 1 Close the front cover.
- 2 Press **SET UP** (making the light come on).
- 3 Wait until **HEATER CONFIG** stops flashing and stays steadily lit.
- 4 Make sure you are at the top menu.
If you are not at the top menu, press **MENU**, then press **◀**.

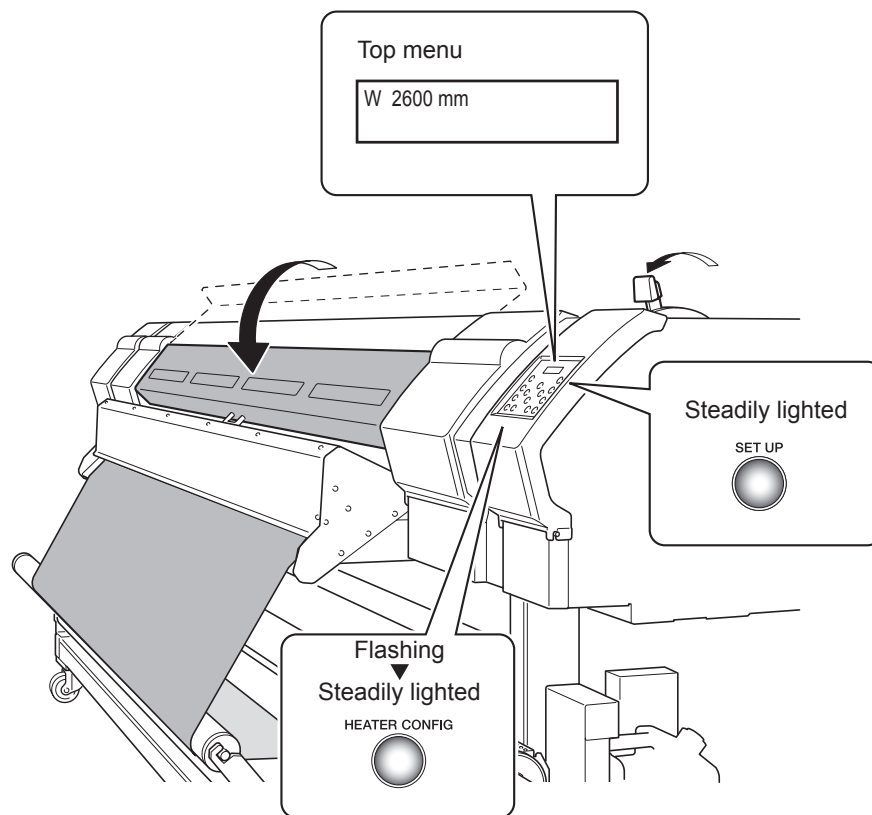

Printing Is Not Possible in These Situations

- The machine does not run when the front cover is open. Also, never open it when printing is in progress. Doing so interrupts printing.
- Data from the computer is not accepted when **SET UP** is dark.
- **SET UP** does not light up when media is loaded incorrectly.
- Printing does not start until **HEATER CONFIG** lights up.
- Data from the computer is not accepted when you are not at the top menu.

Printing Tests and Cleaning

We recommend performing a printing test to check for problems such as dot drop-out before you carry out actual printing. If problems such as dot drop-out are found, clean the print heads.

How to Perform a Printing Test

Hold down for one second or longer.

TEST PRINT

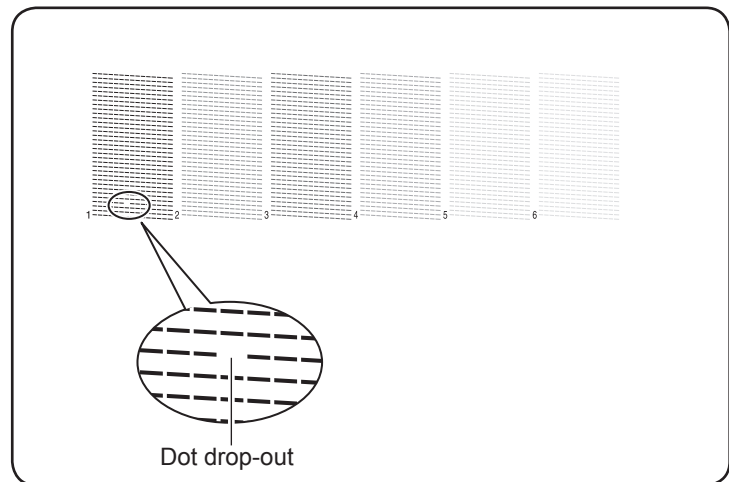

Test pattern

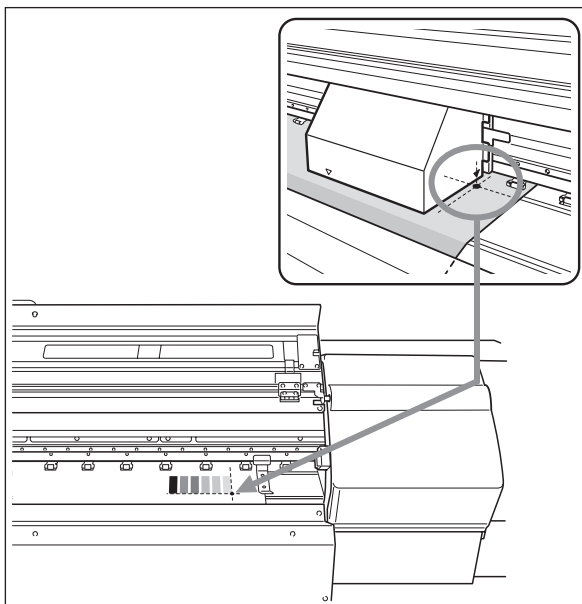

Holding down **TEST PRINT** for one second or longer prints a test pattern.

You can print the test pattern where you want by using **◀** **▶** **▼** to move the print heads, then pressing **BASE POINT**. The front cover may be open during movement, but be sure to close it before you press **TEST PRINT**.

How to Perform Cleaning

When a printing test reveals dot drop-out or the like, perform cleaning for just the head that is incapable of correct printing. Compared with performing cleaning for all heads, this can reduce the amount of ink consumed.

Procedure

1 CLEANING
NORMAL CL.

Press **CLEANING**.

2 NORMAL CL.
_ 1 2 3 4 5 6

Press **▶**.

3 NORMAL CL.
1 3 _ 6

Use **◀** **▶** to choose the number of a head that is not to be cleaned.

Use **▲** **▼** to get rid of the number display.

Repeat this procedure to display the numbers of only the heads that require cleaning.

Cleaning is performed only for the heads whose numbers are displayed.

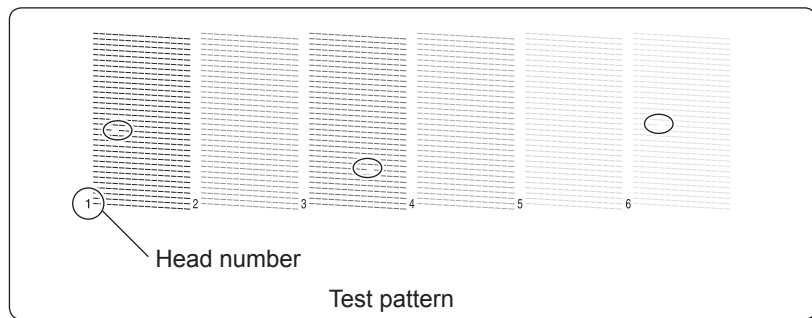

4 CLEANING...
>>

Press **ENTER**.

Cleaning starts.

NORMAL CL.
1 3 _ 6

When it finishes, the screen shown in the figure appears again.

5 W 2600 mm
SETUP SHEET

Press **MENU**.

Press **◀** to go back to the original screen.

6 Perform a printing test again to make sure the dot drop-out has been corrected.

If the problem persists, try performing cleaning a second time.

If the problem doesn't go away even after performing cleaning two or three times, then try cleaning using a different method.

☞ P.62, "When Head Cleaning Is Not Effective"







When you want to clean all heads simultaneously

Hold down **CLEANING** for one second or longer. Cleaning for all heads starts automatically.

2-5 If Ink Runs Out

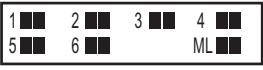
Checking for Remaining Ink

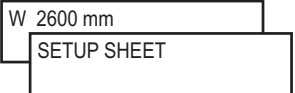
Procedure

-  Press .
Press  several times.
-  Press .
-  Press .
Press  to go back to the original screen.

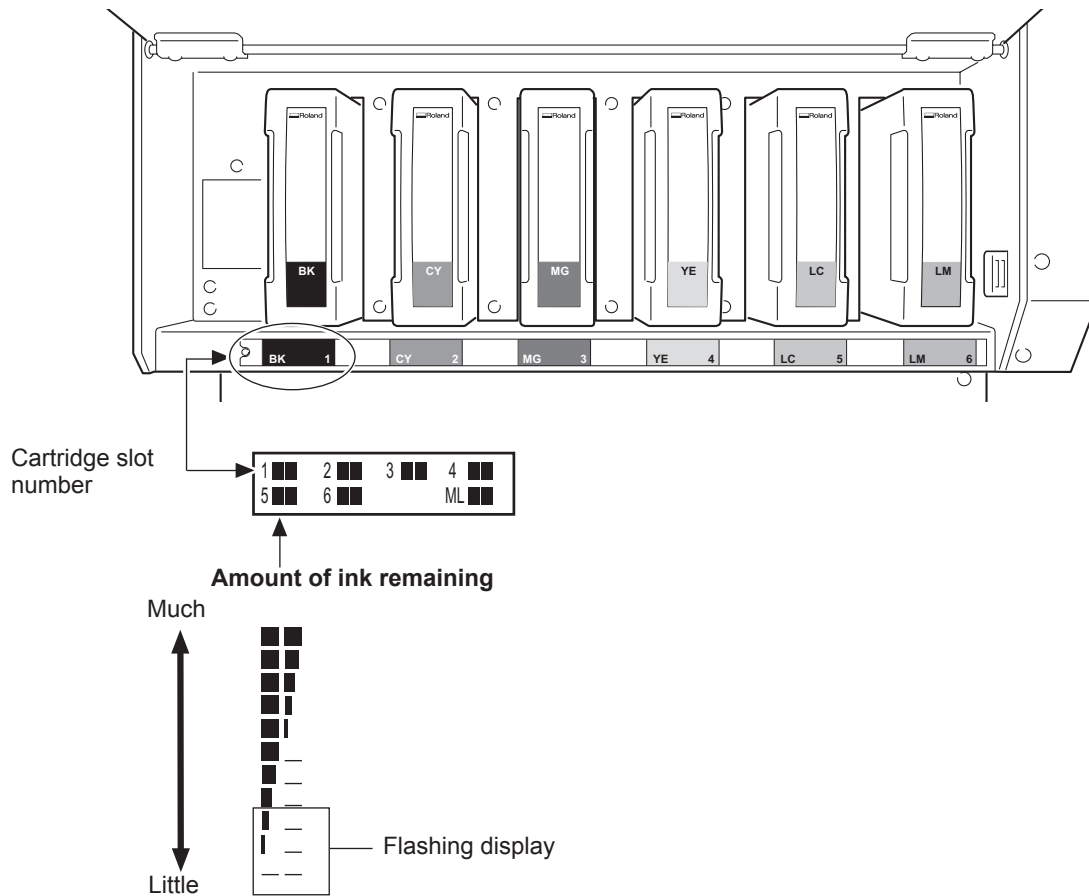

The display shows an approximate guide to the amount of remaining ink, which may differ somewhat from the actual amount remaining.

When Ink Cartridges Become Empty

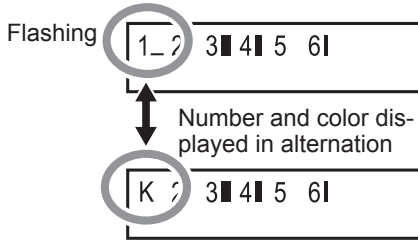

When an ink cartridge is empty, a warning beep sounds and a screen like the one shown in the figure appears.

Replace the cartridge immediately. Replacement is possible even while printing is in progress.

When an ink cartridge becomes empty while printing is in progress, printing does not stop immediately. A certain amount of ink still remains inside the machine, and printing continues until this ink runs out.

Procedure

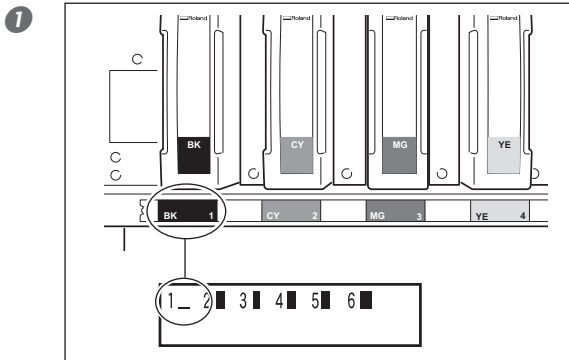

Check which cartridge is empty.

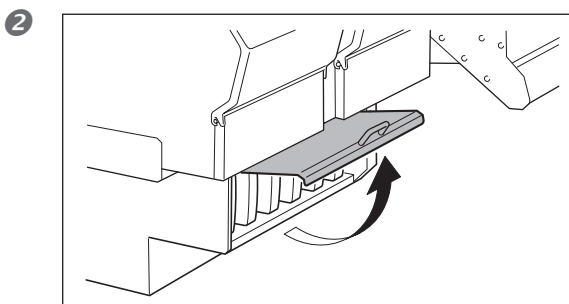

Open the cartridge-slot cover.

3 Pull out the empty cartridge and immediately insert the new one.

- Keep the side with the arrow face up.
- Insert and remove slowly, one at a time.
- Insert firmly, until you hear a beep.

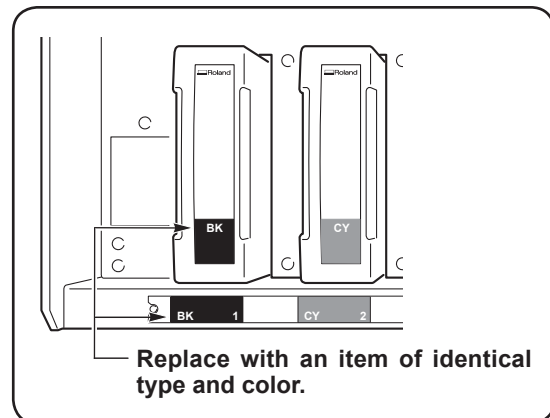
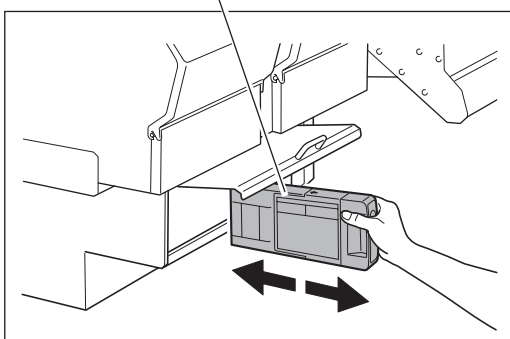

4

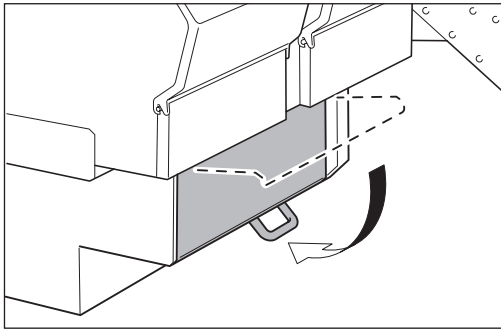

Close the cartridge-slot cover.

Replace Cartridges Before Ink Runs Out

If ink runs out completely, printing pauses.

When you replace a cartridge with a new one, printing resumes after about one minute, but a difference in color may be apparent at the seam between the locations where printing paused and resumed. Be sure to replace cartridges before ink runs out.

Important Notes on Replacing Cartridges

- Be sure to replace with an item of identical type. Never mix items of different types.
- Be sure to replace with a new cartridge. Never insert a partially used ink cartridge. Inserting a partially used cartridge makes the message shown at right appear. Immediately remove the cartridge and replace it with a new one.

DO NOT INSERT
USED CARTRIDGE

- Never allow the machine to stand with an ink cartridge removed. The print heads may become clogged.
- Be sure to carry out replacement according to the instructions given in this manual.
- Never remove a cartridge while the sub power is switched off. Doing so may cause ink to leak or spill.

⚠WARNING

Never store ink, maintenance fluid, or discharged fluid in any of the following locations.

- Any location exposed to open flame
- Any location where high temperature may occur
- Near bleach or any other such oxidizing agent or explosive material
- Any location within the reach of children

Fire may be a danger. Accidental ingestion by children may pose a health hazard.

Chapter 3

Maintenance and Adjustment

3-1 Daily Care and Maintenance

Disposing of Discharged Ink

CHECK
DRAIN BOTTLE





Press 

The drain bottle collects discharged fluid. Dispose of collected material before the bottle becomes full. A message appears when a certain amount of discharged fluid collects in the bottle. Follow the procedure below to discard the discharged fluid.

1. Choose the "DRAIN BOTTLE" menu item.

1  Press .
Press  several times.

2  Press .
Press .

3  Press .
Press .
Press .

4  Preparations are complete when this screen appears.

2. Empty the bottle by discarding the discharged fluid.

⚠ CAUTION Before you detach the drain bottle, be sure to wait for the screen to display "EMPTY DRAIN BOTTLE."

Failing to follow this procedure may cause discharged fluid to flow out of the tube and spill, soiling your hands or the floor.

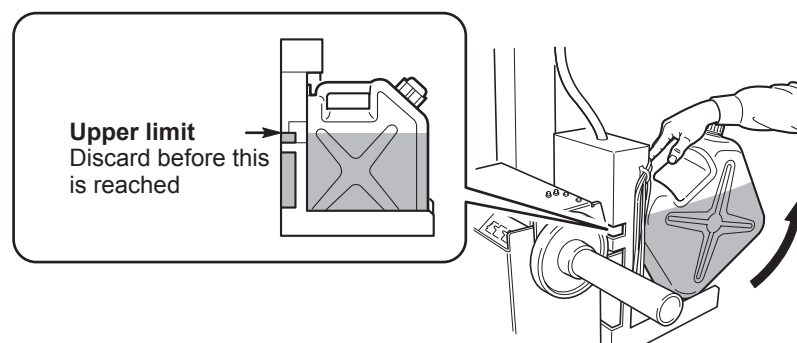

3. Attach the emptied bottle and reset the discharged-fluid count.

1 RESET DRAIN
COUNTER ↵

Press **ENTER**.

2 MAINTENANCE
DRAIN BOTTLE ↵

Press **ENTER** a second time.

3 W 2600 mm
SETUP SHEET

Press **MENU**.

Press **←** to go back to the original screen.

⚠WARNING

Never store discharged fluid in any of the following locations.

- Any location exposed to open flame
- Any location where high temperature may occur
- Near bleach or any other such oxidizing agent or explosive material
- Any location within the reach of children

Fire may be a danger. Accidental ingestion by children may pose a health hazard.

⚠CAUTION

To store discharged fluid temporarily, place it in the included drain bottle or in a durable sealed container such as a metal can or polyethylene tank, and cap tightly.

Any spillage or vapor leakage may cause fire, odor, or physical distress.

Dispose of discharged fluid properly, in accordance with the laws in effect in your locale. Discharged fluid is flammable and contains toxic ingredients. Do not attempt to incinerate discharged fluid or discard it with ordinary trash. Also, do not dispose of it in sewer systems, rivers, or streams. Doing so may have an adverse impact on the environment.

Cleaning

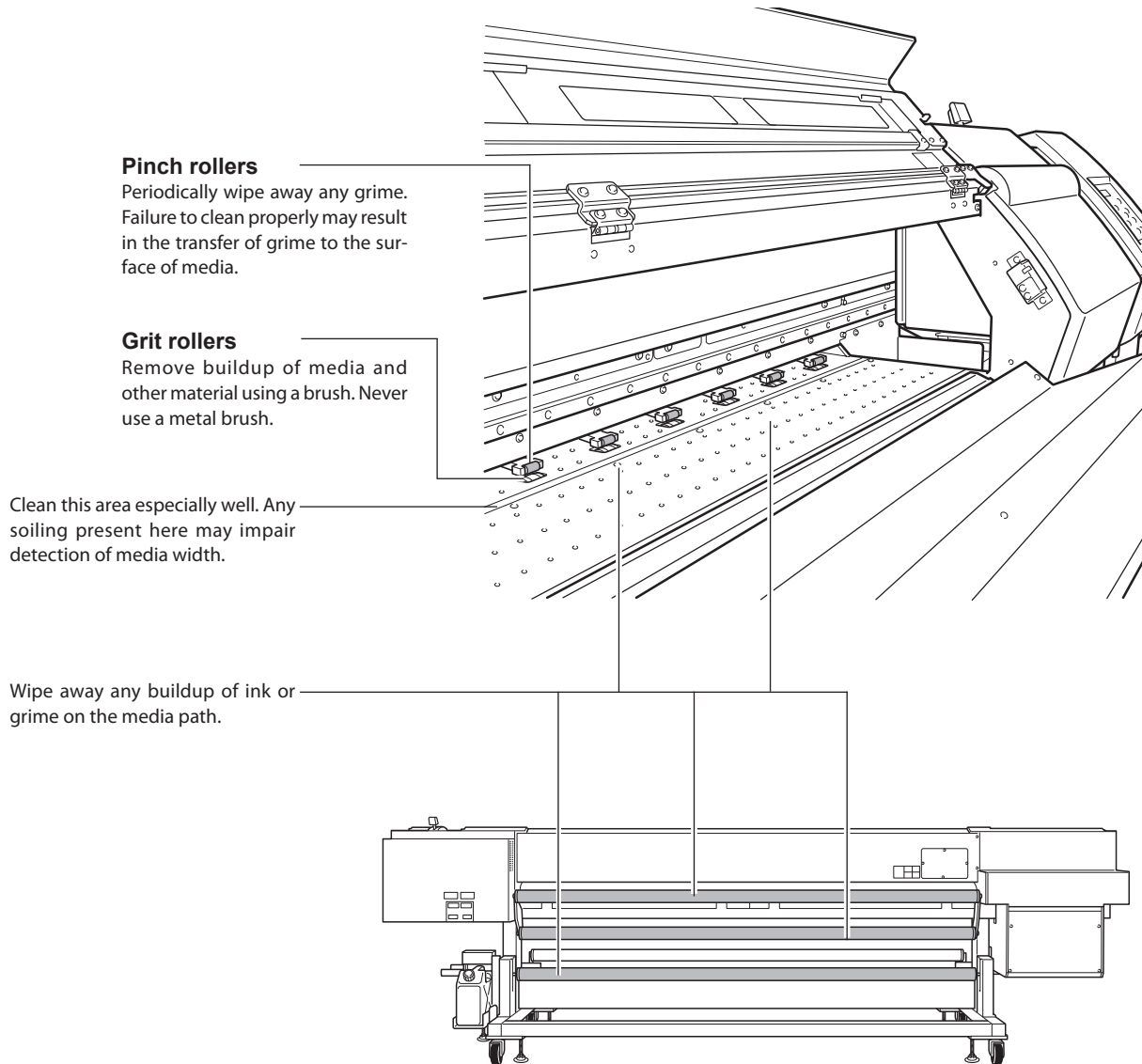

Pinch rollers

Periodically wipe away any grime. Failure to clean properly may result in the transfer of grime to the surface of media.

Grit rollers

Remove buildup of media and other material using a brush. Never use a metal brush.

Clean this area especially well. Any soiling present here may impair detection of media width.

Wipe away any buildup of ink or grime on the media path.

⚠️ WARNING

Never use gasoline, alcohol, thinner, or any other flammable material. Doing so may cause fire.

⚠️ CAUTION

Before attempting cleaning, switch off the sub power and wait until the platen and dryer cool (approximately 30 minutes).

Sudden movement of the machine may cause injury, or hot components may cause burns.

- This machine is a precision device, and is sensitive to dust and dirt. Perform cleaning on a daily basis.
- Clean by wiping with a cloth moistened by neutral detergent diluted with water then wrung dry.
- Never attempt to oil or lubricate the machine.

Care and Maintenance of the Print Heads

Daily Care and Maintenance

To prevent the print heads from drying out or clogging, this machine automatically performs cleaning of the print heads (using its self-cleaning feature).

The machine automatically determines the interval for performing self-cleaning, based on factors such as the ambient temperature. However, this interval can also be changed by you.

☞ P.96, "Changing the Self-cleaning Settings"

Periodic Care and Maintenance

Periodic care is essential to ensuring optimal printing at all times. Based on your frequency of use, periodically clean the heads using a cleaning kit.

☞ P.64, "Cleaning the Heads Using the Cleaning Kit"

Note: The print heads are components that wear out. Periodic replacement is required, with the frequency of replacement depending on use. Purchase them from your authorized Roland DG Corp. dealer.

3-2 When Head Cleaning Is Not Effective

Performing More Powerful Cleaning

When the problems such as dot drop-out are not cleared up by the "normal cleaning," try the more forceful "powerful cleaning." Note, however, that this consumes more ink than "normal cleaning," and too-frequent use may damage the print heads themselves. Avoid using it more than necessary.

In the same way as for normal cleaning, choose and clean only heads that are incapable of correct printing.

Procedure



Press **CLEANING**.
Press **▼**.



Press **▶**.



Use **◀** **▶** to choose the number of a head that is not to be cleaned.

Use **▲** **▼** to get rid of the number display.

Repeat this procedure to display the numbers of only the heads that require cleaning.

Cleaning is performed only for the heads whose numbers are displayed.

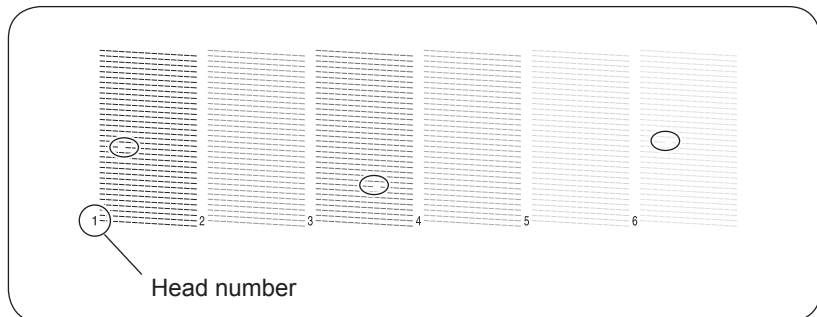

Test pattern

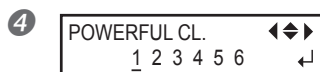

Press **ENTER**.
Cleaning starts.



When it finishes, the screen shown in the figure appears again.

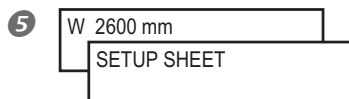

Press **MENU**.
Press **◀** to go back to the original screen.

When Powerful Cleaning Is Not Effective

If problems such as dot drop-out persist even after you have performed powerful cleaning several times, then use the cleaning kit to clean the heads. Such cleaning can be effective when carried out periodically, according to the frequency of use.

☞ P.64, "Cleaning the Heads Using the Cleaning Kit"

3-3 Cleaning the Heads Using the Cleaning Kit

When the Cleaning Kit Becomes Necessary

Periodic Care and Maintenance

Use the cleaning kit to perform head-cleaning periodically, according to the frequency of use.

When dot drop-out or the like occur frequently

When the machine's head-cleaning feature does not correct the problem, clean the heads using the cleaning kit.

- If you use up the cleaning kit, purchase a new one from your authorized Roland DG Corp. dealer.
- The print heads are components that wear out. Periodic replacement is required, with the frequency of replacement depending on use. Purchase them from your authorized Roland DG Corp. dealer.

How to Perform Cleaning

Important Notes on This Procedure

- To prevent the heads from drying out, finish this procedure in 10 minutes or less.
- A warning beep sounds after 10 minutes. At this time, stop work, attach the right side cover, and press **ENTER**. When the head-protection operation finishes, restart the procedure from the beginning.
- Never use any implement other than the included cleaning stick. Cotton swabs or other lint-producing items may damage the heads.
- Never touch the nozzle surface of the heads.
- Stroke the sponges very gently, applying as little pressure as possible. Never rub, scrape, or crush them.

⚠ CAUTION Be sure to perform operations as specified by these instructions, and never touch any area not specified in the instructions. Sudden movement of the machine may cause injury.

1. Change to the print-head manual-cleaning mode.

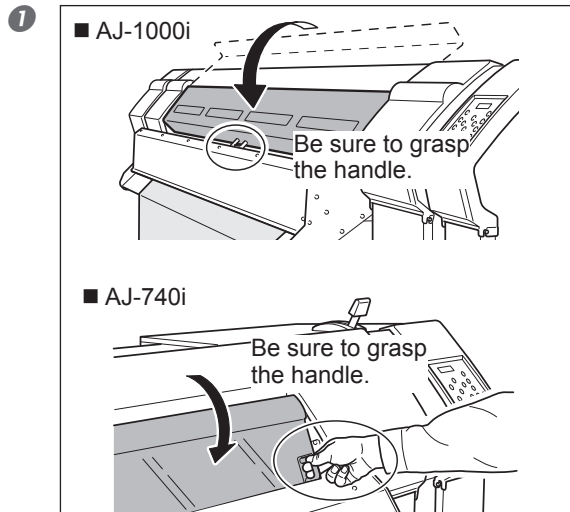

Remove any media from the platen and close the front cover.

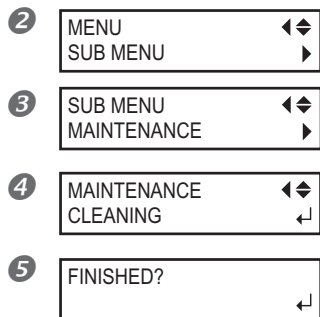

Press **MENU**.
Press **▼** several times.

Press **▶**.
Press **▲**.

Press **▶**.
Press **ENTER**.

Preparations are complete when this screen appears.

2. Remove the right side cover.

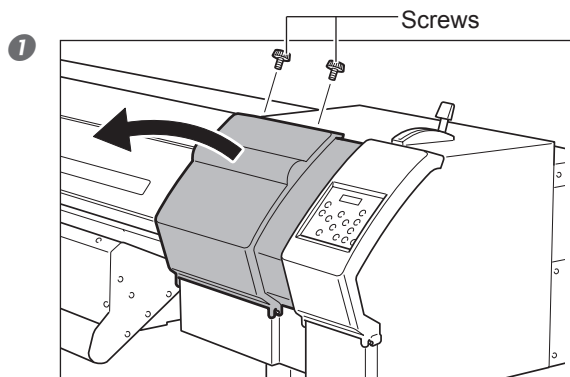

Remove the right side cover.

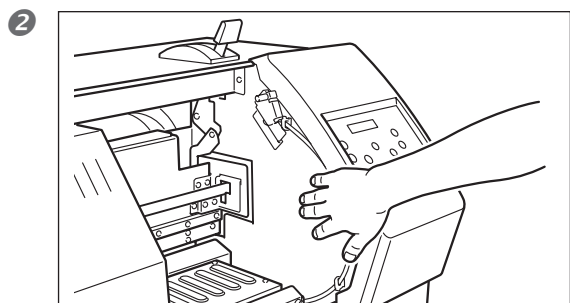

Touch the location shown in the figure to discharge any static electricity.

3. Clean using the cleaning stick. Be especially careful to clean away any fibrous dust (lint).

Clean in the sequence shown in the figure below.

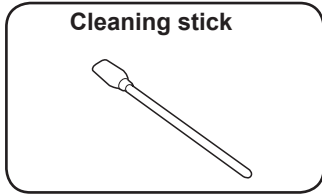

Be sure to clean using one of the included cleaning sticks.

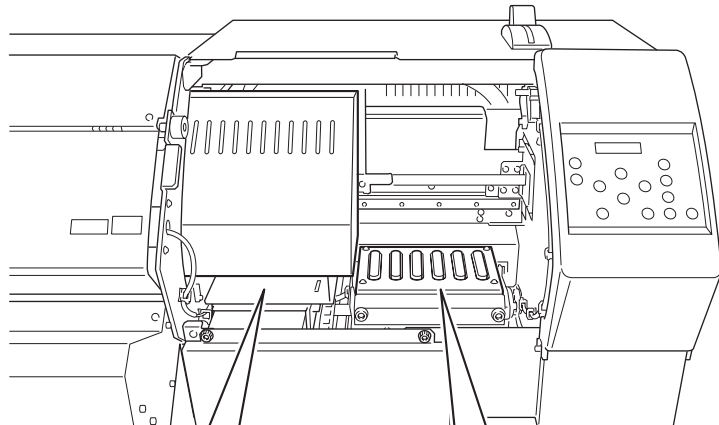

Never touch the nozzle surface. Clean only the metal frame.

Gently stroke the sponge. Never rub with force.

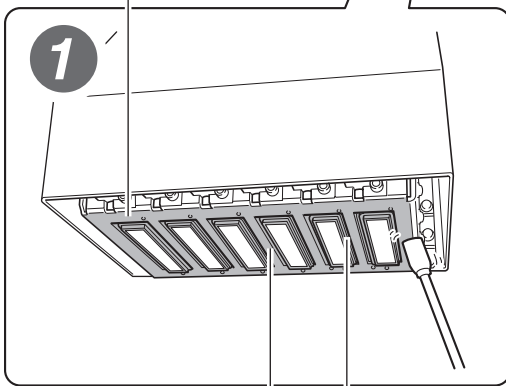

Area to clean

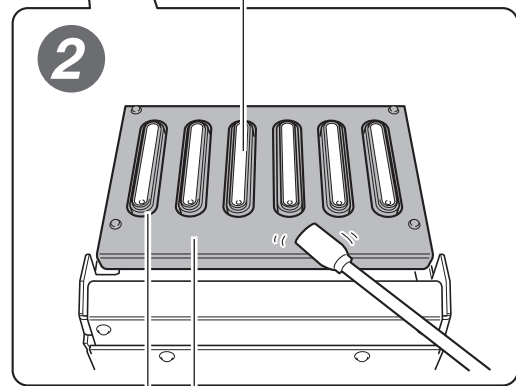

Area to clean

You can clean away ink buildup using maintenance liquid.

If ink has built up around the sponges, it may be a good idea to moisten a cleaning stick with the maintenance liquid in the tray and clean away the buildup.

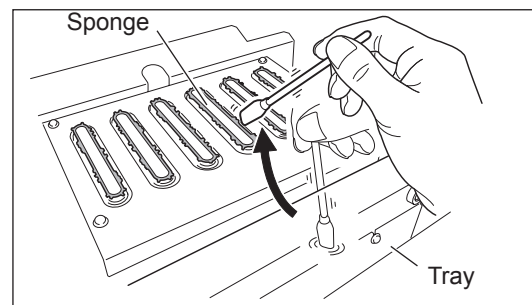

4. Reattach the right side cover and quit the manual cleaning mode.

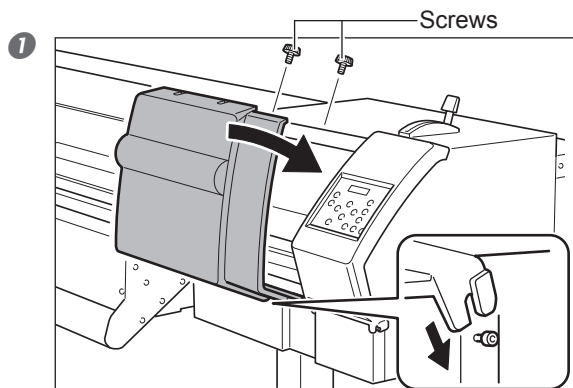

Attach the right side cover.

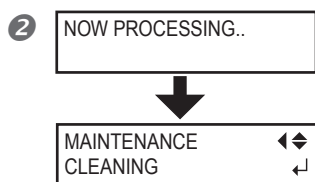

Press **ENTER**.

After the processing to quit the manual cleaning mode ends, the screen shown in the figure appears.



Press **MENU**.

Press **←** to go back to the original screen.

5. Perform a printing test to verify the results of the procedure.

Perform a printing test to check the results.
Perform automatic cleaning several times as required.

3-4 Replacing Consumable Parts

Replacing the Wipers



Press

The wipers are components that you use when cleaning the print heads. When the screen displays a message like the one shown, it means the item needs to be replaced. Replace with new items.

○ To prevent the heads from drying out, finish this procedure in 10 minutes or less.

○ A warning beep sounds after 10 minutes. At this time, stop work, attach the right side cover, and press . When the head-protection operation finishes, restart the procedure from the beginning.

CAUTION

Be sure to perform operations as specified by these instructions, and never touch any area not specified in the instructions.

Sudden movement of the machine may cause injury.

1. Display the [REPLACE WIPER] menu.

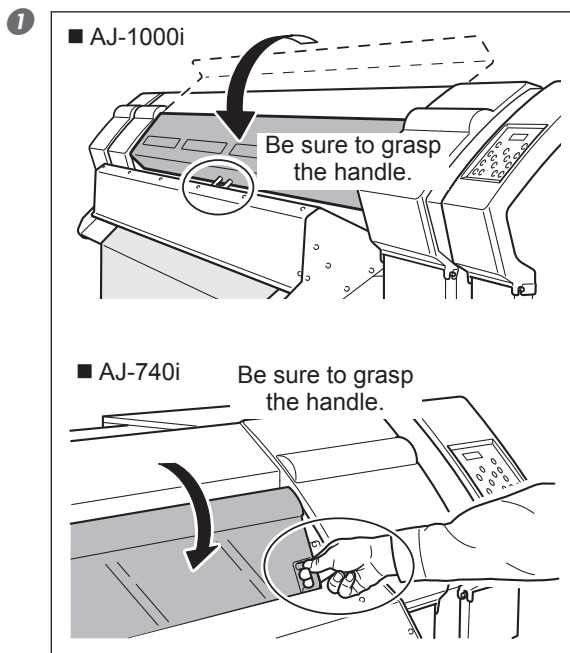

Remove any media from the platen and close the front cover.



Press .
Press several times.



Press .
Press .



Press .
Press .
Press .

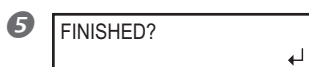

Preparations are complete when this screen appears.

2. Remove the right side cover.

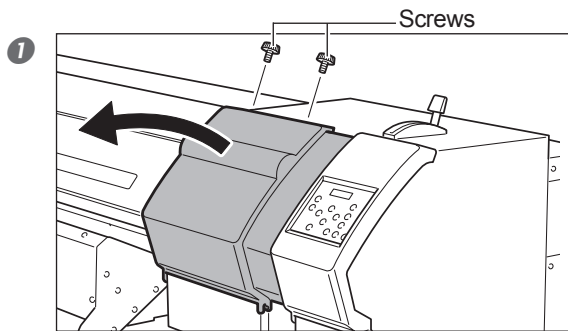

Remove the right side cover.

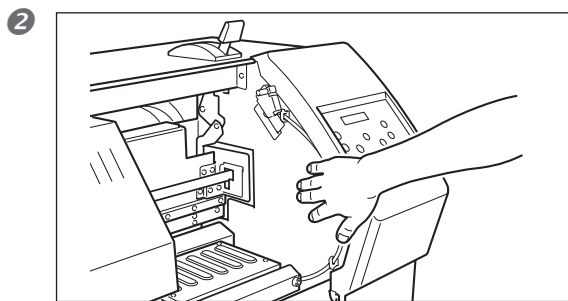

Touch the location shown in the figure to discharge any static electricity.

3. Replace the wipers. Use the included tweezers.

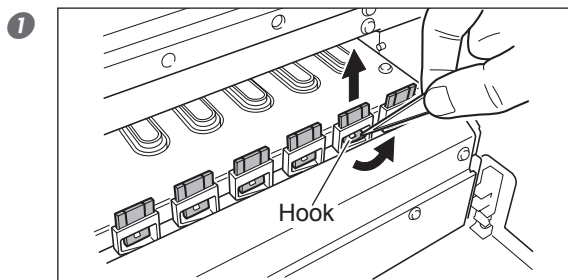

Detach the old wipers.
Detach the hook and pull up and out.

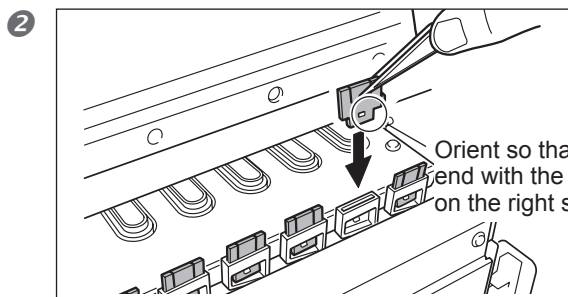

Insert the new wipers.

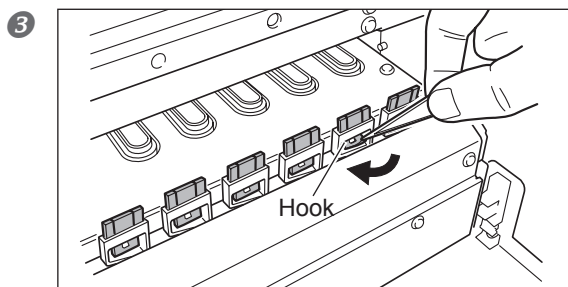

Attach the hook.
Follow this procedure to replace all six wipers.

4. Reattach the right side cover and quit the [REPLACE WIPER] menu.

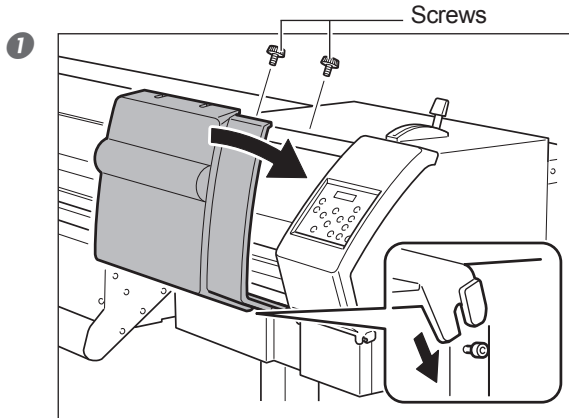

Attach the right side cover.

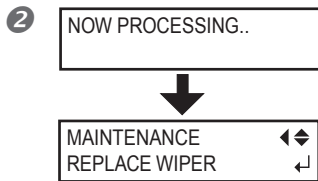

Press **ENTER**.
After the processing to quit the [REPLACE WIPER] menu ends, the screen shown in the figure appears.

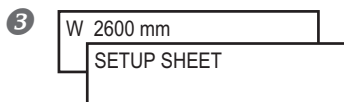

Press **MENU**.
Press **←** to go back to the original screen

4 Perform a printing test to verify the results of the procedure.

Replacing the Maintenance Liquid Cartridge



Press **ENTER**.

If this screen appears, replace the maintenance liquid cartridge within one month. The maintenance liquid is used to clean the print heads and soiled wipers, and to keep the wipers from drying out.

○ To prevent the heads from drying out, finish this procedure in 10 minutes or less.

○ A warning beep sounds after 10 minutes. At this time, stop work, attach the right side cover, and press **ENTER**. When the head-protection operation finishes, restart the procedure from the beginning.

⚠ CAUTION

Be sure to perform operations as specified by these instructions, and never touch any area not specified in the instructions.

Sudden movement of the machine may cause injury.

1. Enter the cartridge-replacement mode.

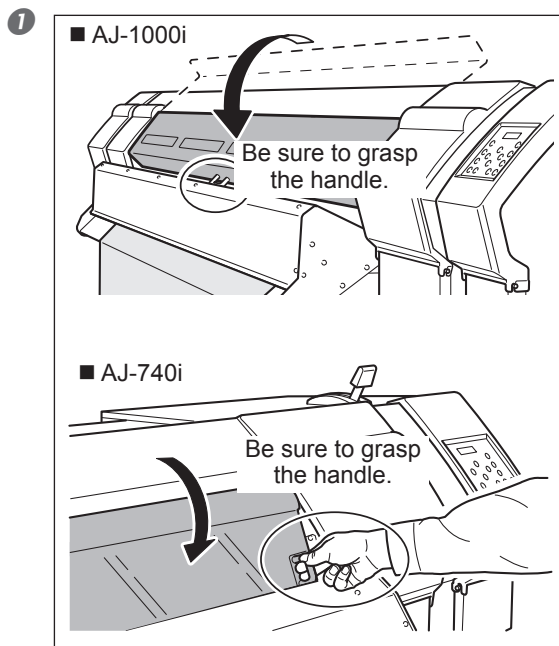

Remove any media from the platen and close the front cover.



Press **MENU**.
Press **▼** several times.

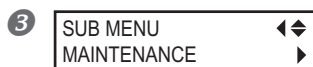

Press **▶**.
Press **▲**.

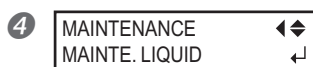

Press **▶**.
Press **▼** twice.
Press **ENTER**.

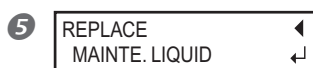

Preparations are complete when this screen appears.

2. Remove the right side cover and the maintenance cover.

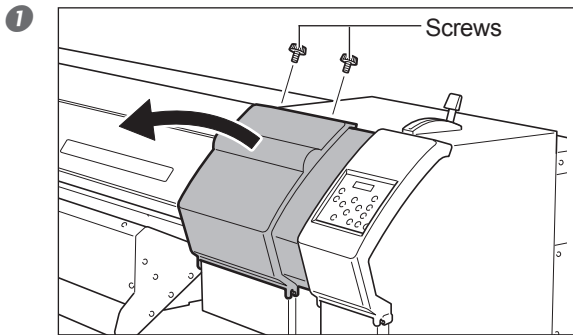

Remove the right side cover.

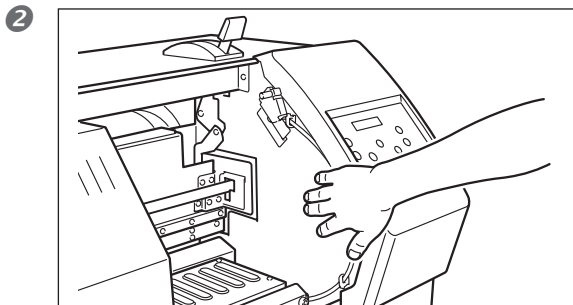

Touch the location shown in the figure to discharge any static electricity.

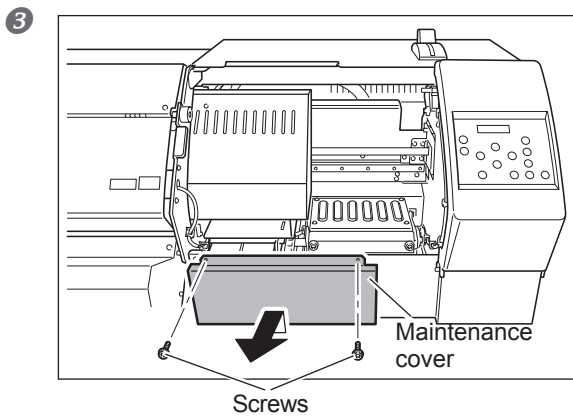

Remove the maintenance cover.

3. Replace the maintenance liquid cartridge.

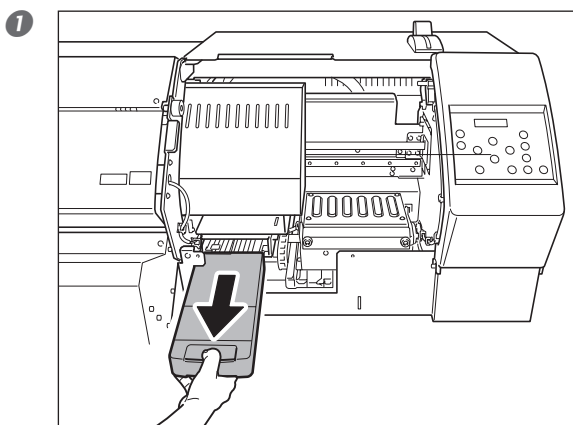

Pull out the empty cartridge.

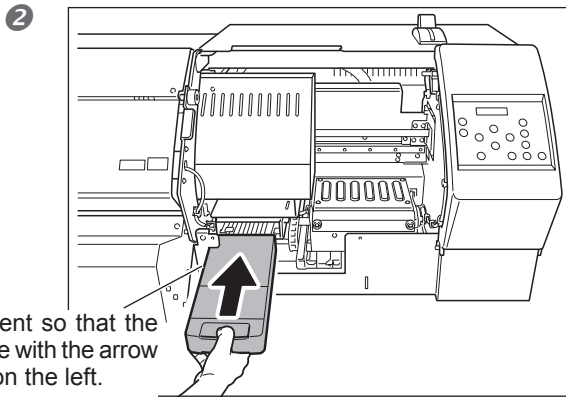

Orient so that the side with the arrow is on the left.

Insert the new cartridge.
Insert firmly, until you hear a beep.



Press **ENTER**.
Preparations are complete when this screen appears.

4. Discard any maintenance liquid that has collected in the tray.

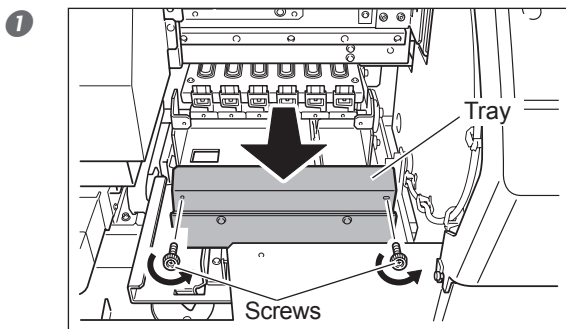

Remove the screws shown in the figure and pull out the tray.

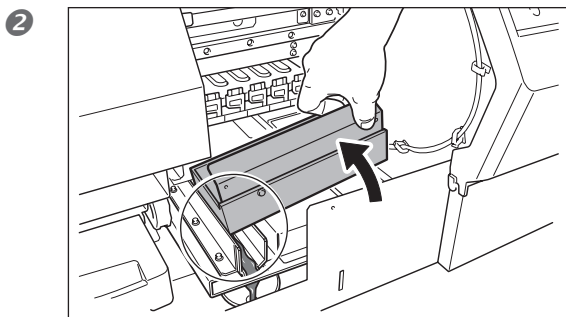

Tilt the tray to pour out the maintenance liquid to the location shown in the figure.

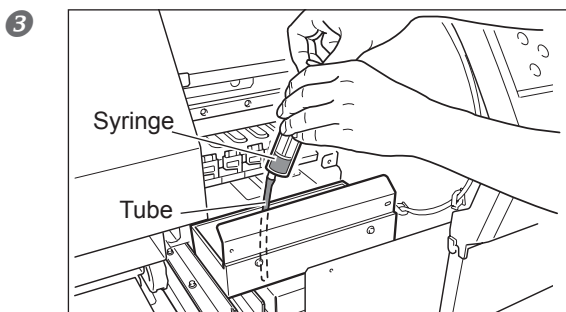

Take up any remaining maintenance liquid with the syringe.
Immediately discard the taken-up maintenance liquid into the drain bottle, leaving none inside the syringe. Otherwise the rubber parts of the syringe may swell and make the syringe unusable.

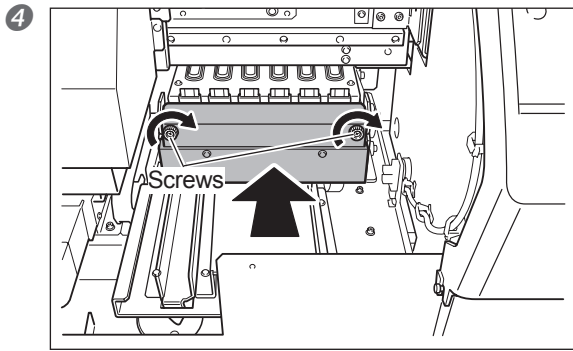

Return the tray to its original location and tighten the screws.

5. Reattach the removed covers and quit the cartridge-replacement mode.

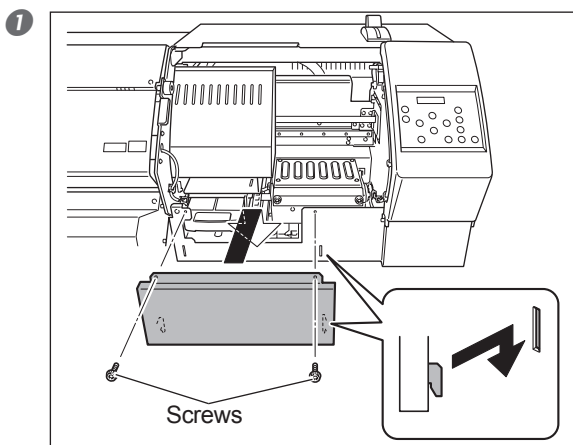

Attach the maintenance cover.

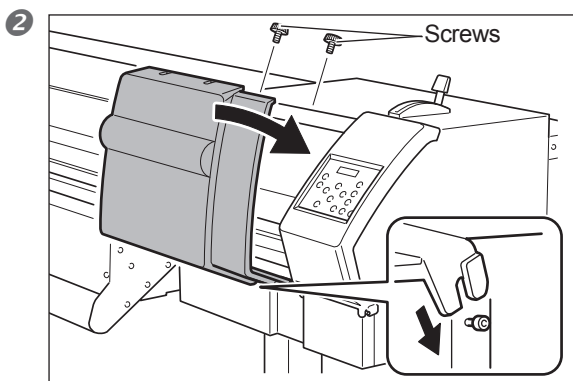

Attach the right side cover.

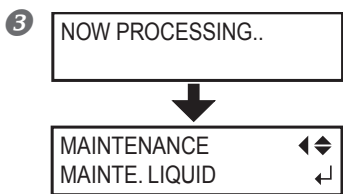

Press **ENTER**.
After the processing to quit the cartridge-replacement mode, the screen shown in the figure appears.

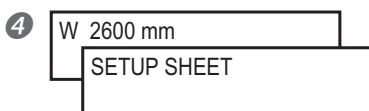

Press **MENU**.
Press **←** to go back to the original screen.

5 Perform a printing test to verify the results of the procedure.

3-5 When Not in Use for a Prolonged Period

Important Points to Observe

When the machine is not in use for a prolonged period, be sure to observe the following important points.

Keep the Main Power Switched On at All Times

When the main power is on, the machine performs cleaning of the print heads automatically to match the ambient temperature and humidity (self-cleaning feature). Leaving the main power switched off may result in hardening of the ink, clogging of the print heads, or other malfunction. Leave the main power switched on even when the machine is not in use. When circumstances compel you to switch off the main power, first consult your authorized Roland DG Corp. dealer.

Also, if a power outage or the like causes the main power to go off, switch the main power on again as soon as power is restored. Then repeat cleaning and printing tests until dot drop-out has been eliminated. If this does not resolve the problem, contact your authorized Roland DG Corp. dealer.

Keep at a Constant Temperature and Relative Humidity

Even when the machine is not in use, keep it at a temperature of 5 to 40°C (41 to 104°F) and a relative humidity of 20 to 80% (with no condensation). Temperatures that are too high may degrade the ink and cause malfunction.

Once a Week, Check the Amount of Ink and Maintenance Liquid Remaining

Self-cleaning uses up ink and maintenance liquid. If either one runs out completely, self-cleaning cannot be performed, which may result in clogging of the print heads or other malfunction. Check the amount remaining in the cartridges at least once a week. When the remaining amount displayed at the [INK REMAINING] menu is flashing, it means that the cartridge will become empty within a week. Replace the cartridge promptly.

- ☞ P.53, "Checking for Remaining Ink"
- ☞ P.54, "When Ink Cartridges Become Empty"

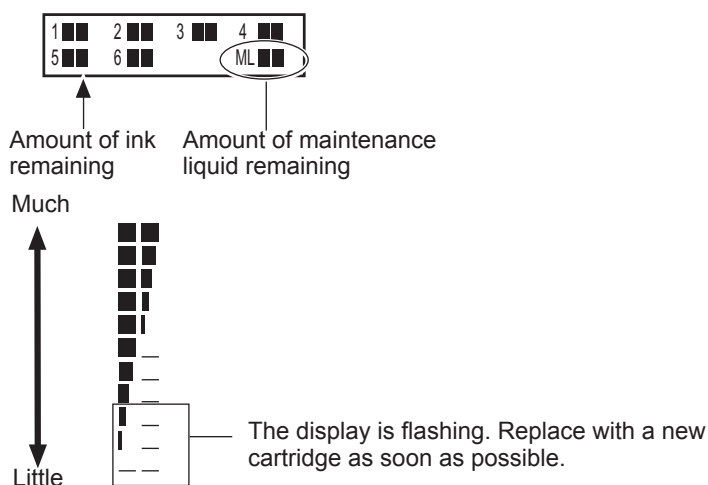

If a message appears

When the machine has been out of use for some time, if the message shown below remains displayed on the screen and a warning beep sounds, it means that ink or maintenance liquid has run out completely, and self-cleaning cannot be performed. Take action promptly. Failure to do so may result in clogging of the print heads or other malfunction.



Ink has run out. Replace the cartridge indicated by the flashing number.
☞ P.54, "When Ink Cartridges Become Empty"



Maintenance liquid has run out. Press **ENTER** then display the [MAINTE. LIQUID] menu item and replace the maintenance liquid cartridge.
☞ P.71, "Replacing the Maintenance Liquid Cartridge"

3-6 When Moving the Machine

When moving the machine to another location, consult your authorized Roland DG Corp. dealer.

CAUTION

Entrust operations such as transportation, unloading, and emplacement to trained workers.

Handling requires special equipment and training. Performing operations in an unreasonable manner may result in a major accident.

Chapter 4

Feature Reference

4-1 Pausing or Canceling Printing

Canceling Printing Before It Finishes

Procedure

- 1 Press **PAUSE**.
- 2 Hold down **SET UP** for one second or longer.
- 3 Stop sending printing data from the computer.

Description

PAUSE pauses printing. Pressing **PAUSE** a second time here resumes printing, but a horizontal stripe is produced at the location where printing was stopped. We do not recommend resuming printing.

4-2 Setting the Printing Position and Margins



Shifting the Print-start Position to the Rear

Procedure

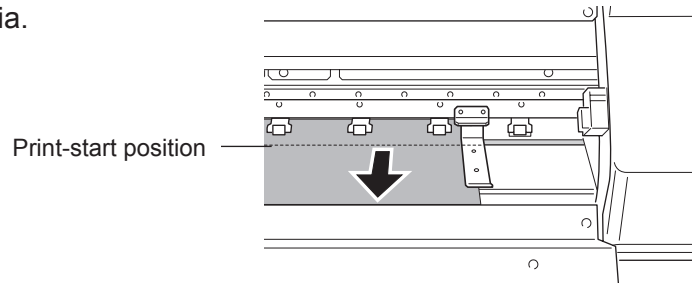
Use  to move the media.







Description

Using  to move the media lets you shift the print-start position toward the rear. Note, however, that moving the media a long distance with  may subject the machine to a large load. Never move continuously for more than one minute. Doing so may activate a protective feature and result in an error. Also, never use . Doing so may cause the media to be pulled from the take-up unit with undue force, resulting in an error or malfunction.



Shifting the Printing Position to the Left

Procedure

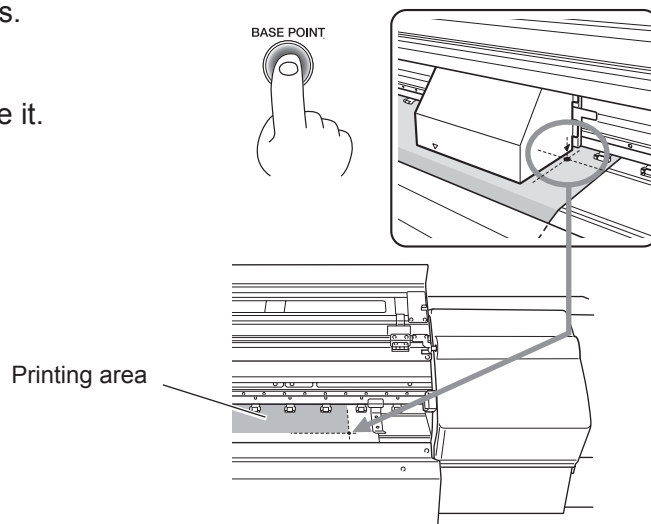
- 1 Use   to move the heads.
- 2 Press .
- 3 If the front cover is open, then close it.
- 4 Press .















Description

You can shift the printing position to the left by using . Note, however, that this setting must be made for each individual page. When the printing of one page finishes, the left-right positioning returns to its default value. When the position has been set,  lights up and the screen displays the printable width at the set position. This feature is also available when printing various test patterns, and can help you use media with less waste. Note, however, that the left and right positions are not restored to their defaults for test patterns.

4-3 Making Simple Changes to the Printer Settings to Match the Media

Saving Optimized Media Settings As Preset Values

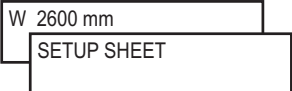
Procedure

-  Press  .
-  Press  .
Press  .
-  Press  .
Use  and  to select any one from NAME1 to NAME8.
Press  to save.
The present menu settings are saved in the preset you chose in step 3.
-  Press  .
Press  to go back to the original screen.

Description

Using the [PRESET] menu lets you easily change a wide variety of settings to optimize them for the media. Making changes for each menu item every time you change the media can be troublesome. That's why it can be useful to save the menu-item settings optimized for an often-used type of media as a preset. The next time you use the media, you can change the menu-item settings to the optimal values for the media simply by loading the preset you saved. You can group together the settings you've made at the menus shown below and save them as a preset.







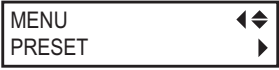

Menu item	Reference page
[FEED FOR DRY]	P.95 , "Drying the Trailing Edge of the Printing Area on the Dryer"
[CALIBRATION]	P.86 , "Performing Feed Correction to Alleviate Horizontal Bands and the Like"
[VACUUM POWER]	P.90, "Preventing Media from Coming Loose"
[SHEET TYPE], [SHEET WIDTH], [SHEET POS.]	P.88, "Using Transparent Media"
[BLOWER FAN]	P.98, "Switching the Blower Fan On and Off"
[ADJUST BI-DIR SIMPLE SETTING]	P.83, "Correcting for Misalignment in Bidirectional Printing"
[ADJUST BI-DIR DETAIL SETTING]	P.84, "Correcting for Misalignment in Bidirectional Printing More Precisely"
[FULL WIDTH S]	P.91, "Speeding Up Printing for Narrow Media"
[PREHEATING]	P.97, "Determining How the Media Heating System Operates"
[PRE],[PRINT],[DRYER]	P.48, "Making the Temperature Setting for the Media Heating System"
[HEAD HEIGHT]	P.82, "Adjusting Head Height to Match Media Thickness"

You can save up to eight presets. You can assign a name to each preset. Using media names may aid recognition and clarity.

- ☞ P.81, "Loading a Saved Preset"
- ☞ P.81, "Assigning a Name to a Preset"



Loading a Saved Preset

Procedure

- 1  Press .
- 2  Press  twice.
Use   to select the name of a preset you want to load.
- 3  Press  to load.
The settings are changed and the screen shown in the figure appears.



















Description

This loads a saved preset. You can select any one of eight types of presets. (When no names have been assigned, you select from among NAME1 through NAME8.)

If you load a preset while  is illuminated,  goes dark. To start printing, press  once more and redo the preparations for printing.

Assigning a Name to a Preset

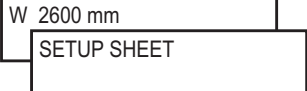
Procedure

- 1  Press .
Press .
Press  twice.
- 2  Press .
Use   to select any one from NAME1 to NAME8.
- 3  Press .
Use   to enter a character.
- 4  Press .
Use   to enter the next character.
Enter the following characters in the same way.
When you're finished entering text, press .
- 5  Press .
Press  to go back to the original screen.

Description











This assigns a name to a saved preset. Using media names may aid recognition and clarity.

The characters you can enter are "A" through "Z," "0" through "9," and the "-" character. You can enter up to 15 characters, including spaces.

4-4 Optimizing Printing to Match Media Thickness

Adjusting Head Height to Match Media Thickness

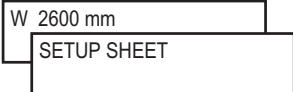
Procedure

-  Press .
Press  several times.
-  Press .
Use   to make the setting for the height.
Press  to enable the setting.
-  Press .
Press  to go back to the original screen.

Description

Depending on the media, media may wrinkle or come loose from the platen during printing, increasing the chance of contact with the print heads. When you are using such media, adjust the head height to "HIGH."

Note that the height of the heads cannot be determined by just the thickness of the media.

When the height is set to "LOW," the media clamps cannot be used. Except in special cases, the "LOW" setting should never be used. Doing so may cause the heads to strike the clamps and become damaged.

Default Setting

[HEAD HEIGHT]: MIDDLE

Correcting for Misalignment in Bidirectional Printing

Procedure

1. Print a test pattern.



Press **MENU**.
Press **▼**.



Press **▶**.
Press **ENTER** to start printing.

2. Read the correction values from the test pattern.

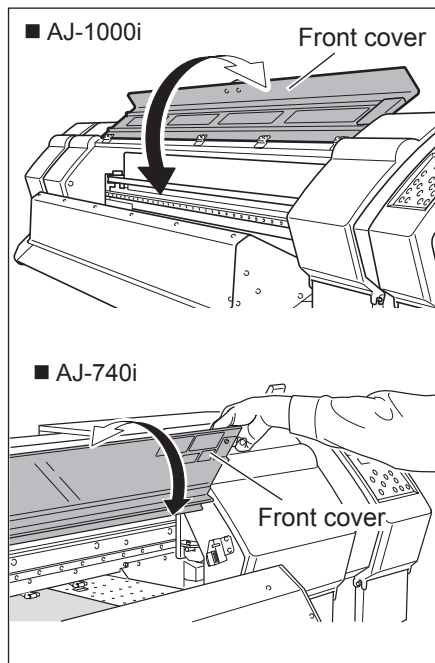

Before making the reading, open the front cover. After making the reading, close the front cover. Grasp the handle to open and close.

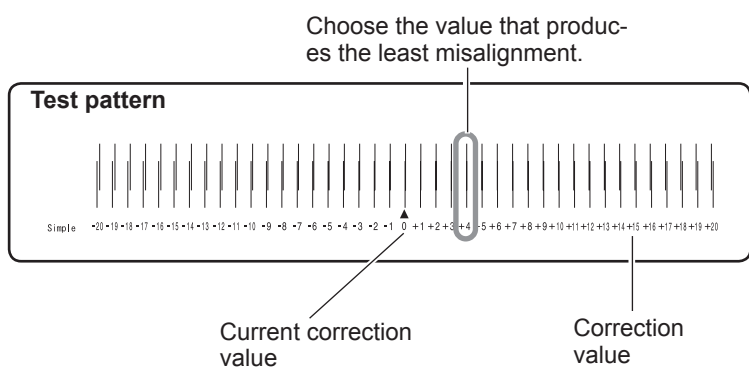

3. Enter the correction values that you read.



Press **▼**.



Press **▶**.
Use **▲** **▼** to set the correction values.
Press **ENTER** to enable the setting.

4. Go back to the original screen.

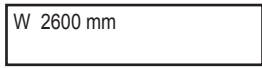

Press .
Press to go back to the original screen.

Description

The bidirectional-printing mode (in which the heads perform printing during both their outbound pass and return pass) offers the advantage of being able to shorten printing times, but subtle misalignment occurs during the outbound and return passes. The procedure to correct this and eliminate misalignment is bidirectional correction. This misalignment varies according to the head height and the thickness of the media, so we recommend performing correction to match the media you're using.

Correcting for Misalignment in Bidirectional Printing More Precisely

Procedure

1. Print a test pattern.



Press .
Press .



Press .
Press twice.



Press .

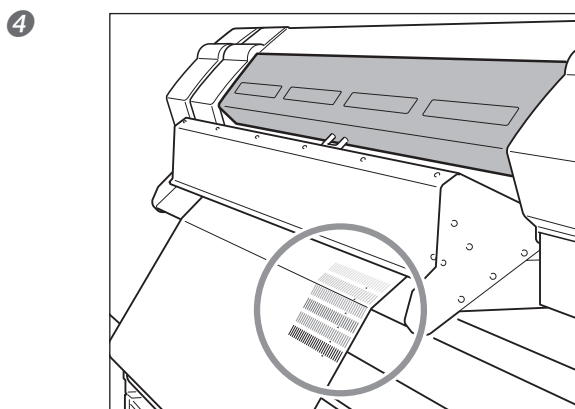

Press to start printing.

When printing ends, the media is fed out and the printed test pattern is moved to the location shown in the figure.

2. Read the correction values from the test pattern.

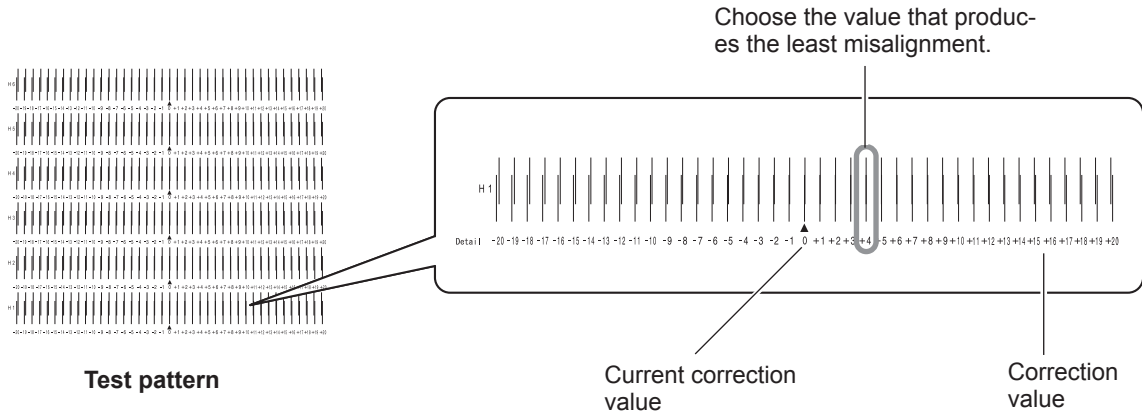

3. Enter the correction values that you read.

Enter the corresponding correction values for H1 through H6.

1

DETAIL SETTING	◀▶
SETTING	▶

 Press .

2

H1	H2	H3	◀▶
0	0	0	↵

 Press .
Use to select.
Use to set the correction values.
Press to enable the setting.

H4	H5	H6	◀▶
0	0	0	↵

4. Go back to the original screen.

W 2600 mm

 Press .
Press to go back to the original screen.

Description

This corrects, for each head, the minute misalignment that occurs in the bidirectional-printing mode. When further correction is required, such as when adjustment made using [SIMPLE SETTING] do not enhance printing, use [DETAIL SETTING] to make corrections for each head.

Performing Feed Correction to Alleviate Horizontal Bands and the Like

Procedure

1. Print a test pattern.



Press **MENU**.
Press **▼** several times.



Press **▶**.
Press **ENTER** to start printing.

2. Check the test pattern you printed.

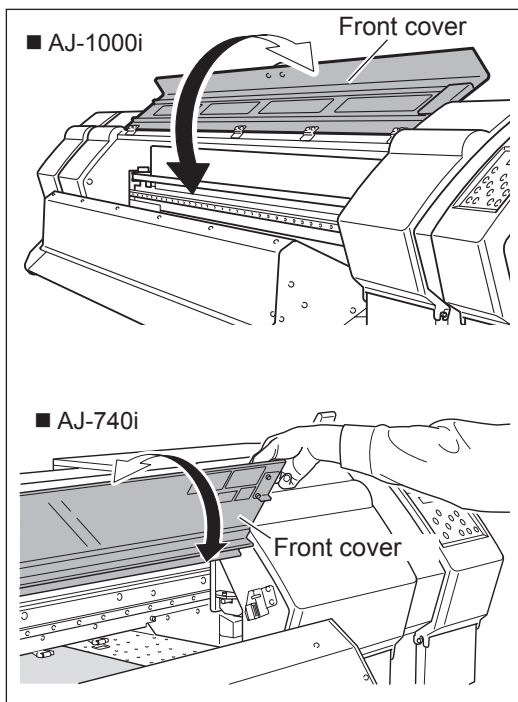

Before making the reading, open the front cover. After making the reading, close the front cover.

Grasp the handle to open and close.

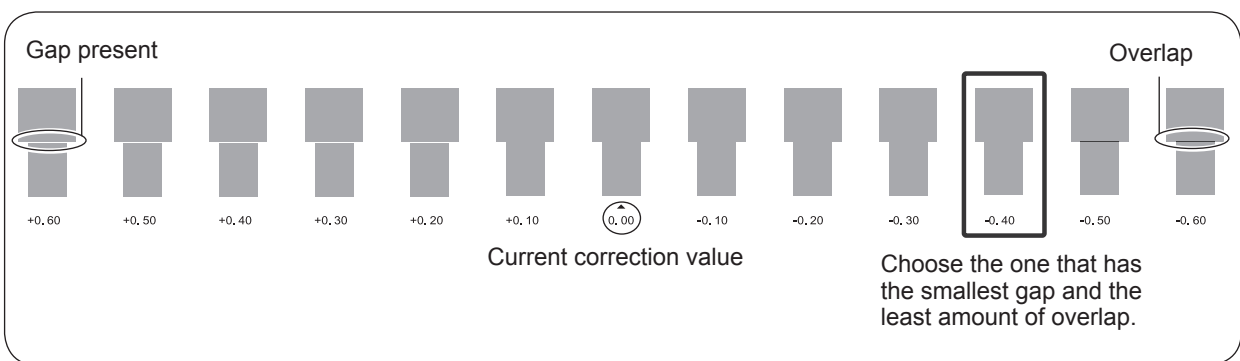

Test pattern

3. Enter the correction value.



Press .
 Press .
 Use to make the setting for the correction value.
 Press to enable the setting.

4. Go back to the original screen.

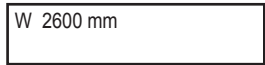

Press .
 Press to go back to the original screen.

Description

The movement transfer of media experiences subtle changes due to the thickness of the media and the temperature of the media heating system. When the movement distance becomes discrepant, horizontal stripes are more likely to occur during printing. We recommend performing correction to match the media you're using and the media heating system. Repeat the process of printing a test pattern and entering a correction value a number of times to find the optimize value.

It may be also be a good idea to examine actual printing, and reduce the correction value if white horizontal stripes are prominent or increase the value if dark horizontal stripes are prominent.

Printing this test pattern using parameters identical to those for actual printing. Examples such as printing on media scraps may not yield correct results.

Note, however, that you can also make this setting on the computer (by, for example, choosing the media type in the RIP program you are using). Use this feature when you want to make the setting on the printer, without changing any settings on the computer. When you have made the setting on the computer, the computer's setting is used and the printer's setting is ignored.

Default Setting

[SETTING]: 0.00%

Changing the Feed-correction Value During Printing

Procedure



While printing is in progress, press .



Press .
 The current correction value is displayed.



Use to set the correction value.
 Press to enable the setting.
 The changed correction value is saved and immediately applied to printing.

Description

If white or dark-colored stripes appear during printing, you can change the feed-correction value without stopping the printing operation in progress. If white horizontal stripes appear, you make the correction value smaller. If dark horizontal stripes appear, you make the value larger. You can change the correction value regardless of whether settings made on the machine or settings made on the computer take precedence.

A correction value set while printing is in progress is saved only as a setting on the machine.

4-5 Accommodating Various Kinds of Media









Using Transparent Media

Procedure











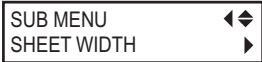

1. Load transparent media to the printer.

- 1 Refer to "2-2 Loading and Cutting Off Media" and load the media on the machine.



2. Set the media type to "CLEAR."

- 1  Press .
Press  several times.
- 2  Press  twice.
Use   to select "CLEAR."
Press  to enable the setting.
 The screen shown in the figure appears.

3. Make the setting for the media width.

- 1  Press .
Press  several times.
- 2  Press .
Press .
- 3  Press .
Use   to enter the media width.
Press  to enable the setting.
- 4  Press  to go back to the previous screen.

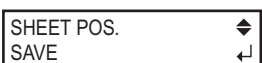
4. Make the setting for the location of the right edge of the media.

- 1  Press .
Press .
The print heads move to the position now set.

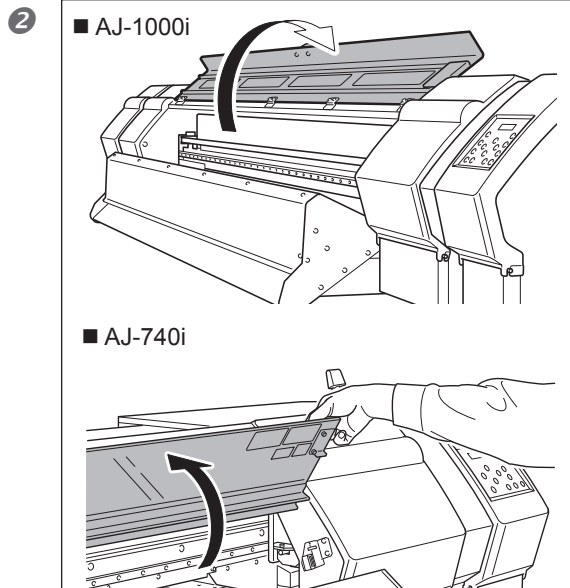

Open the front cover.
Grasp the handle to open.

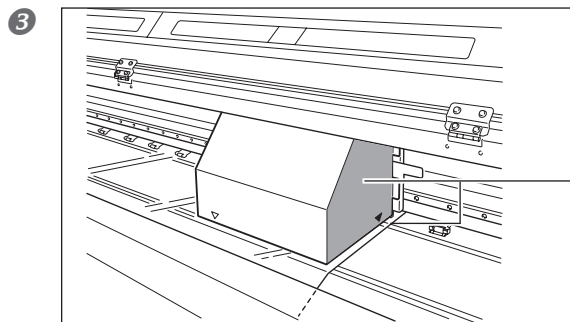

Use ◀ ▶ to move the heads.

Align this surface with the edge of the media.

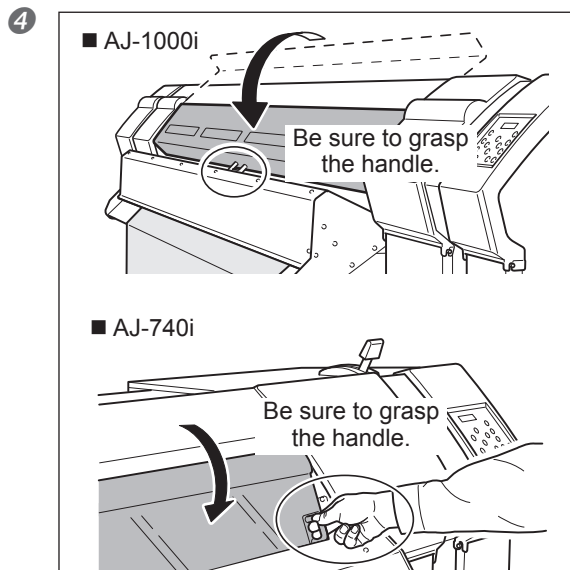

After positioning, close the front cover.
Press **ENTER** to enable the setting.

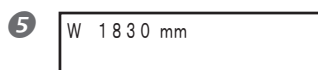

Press **MENU**.
Press ◀ to go back to the original screen, then press **SET UP**.
The top menu appears.

Description

The media width can be sensed automatically for opaque media, but not for transparent media. This means that the width and mounted location of the media must be set manually. Incorrect settings may cause ink to be applied at locations where no media is present.

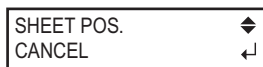

To quit making settings at the [SHEET POS.] menu, use to select "CANCEL," then close the front cover and press .

Note that to keep the heads from drying out, the [SHEET POS.] menu ends automatically after a certain interval, even if you're still making settings there.

The settings for the media width and start position made here are effective only when [SHEETTYPE] is set to "CLEAR." Selecting "OPAQUE" disables the settings, although the setting values are saved in memory. Choosing "CLEAR" again enables the values set previously.

Default Setting

[SHEET TYPE]: OPAQUE
 [SHEET WIDTH]: 2641 mm (AJ-1000i) or 1910 mm (AJ-740i)

Preventing Media from Coming Loose

Procedure



Press .
 Press several times.



Press .
 Press several times.



Press .
 Use and to set the value.
 Press to enable the setting.

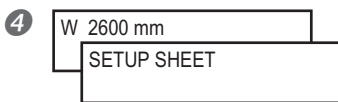

Press .
 Press to go back to the original screen.

Description

The platen uses suction to grip the media and keep it stable. When media comes loose from the platen because it is warped or wrinkled, increasing the suction force may help correct the problem. Conversely, when the media is flimsy and cannot move smoothly, reducing the suction force may help.

When set to "AUTO," the suction force is automatically adjusted to the optimal level for the media width.













You can also make this setting on the computer. When you have made the setting on the computer, the computer's setting is used and the printer's setting is ignored.

Default Setting

[VACUUM POWER]: AUTO

Speeding Up Printing for Narrow Media

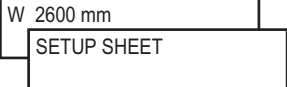
Procedure

- 1  Press .
Press  several times.
- 2  Press .
Press  several times.
- 3  Press .
Use  and  to select "SHEET" or "OFF."
Press  to enable the setting.
- 4  Press .
Press  to go back to the original screen.

Description

Reducing the width of print-head movement to the minimum required width speeds up printing. This is effective mainly when you use media of narrow width. Because the media moves more quickly, the effectiveness of the media heating system also changes. It may be necessary to change the preset temperatures.

"SHEET" matches the range of print-head movement to the width of the media. The parameters for the media heating system change according to the media width.

"OFF" matches the range of print-head movement to the printing data. Movement is limited to the minimum amount necessary, and this can be expected to yield the fastest printing. Note, however, that because the speed of media movement is no longer constant, colors may be uneven.











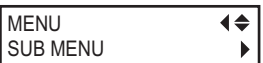

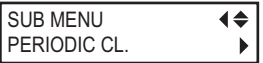
"FULL" makes the speed of media movement constant at all times. Printing speed is slower, but printing quality is the most stable.

Default Setting

[FULL WIDTH S]: FULL

Keeping Media from Being Soiled by Ink Drips

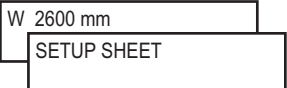
Procedure

- 1  Press .
Press  several times.
- 2  Press .
Press  several times.
- 3  Press .
Use  and  to a value from "1min" to "99min," or "PAGE."
Press  to enable the setting.
- 4  Press .
Press  to go back to the original screen.

Description

Ink tends to collect on the surface of the print heads when you use media prone to occurrence of a static charge, when the ambient temperature is low, and at other such times. Under some conditions, this ink may be transferred to the media. Use this feature at such times. The ink buildup is removed as printing is performed.

When this is set to "PAGE," automatic cleaning is performed every time before printing starts.

When this is set to a value from "1min" to "99min," automatic cleaning is performed when the cumulative printing time reaches the value you set here.

When this is set to "NONE," no automatic cleaning is performed.

Using this feature results in longer printing times. Also, when this is set to a value from "1min" to "99min," printing pauses and so colors may be uneven.











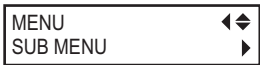

Default Setting

[PERIODIC CL.]: NONE

4-6 Changing How the Printer Operates

Determining What Happens When an Ink Cartridge Is Empty

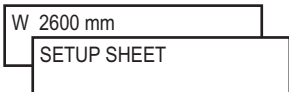
Procedure

-  Press .
Press  several times.
-  Press .
Press  several times.
-  Press  twice.
Use  and  to make the setting.
Press  to enable the setting.
-  Press .
Press  to go back to the original screen.

Description













This setting determines whether printing starts on receipt of printing data when an ink cartridge is empty. When this is set to "STOP," printing does not start until the ink cartridge has been replaced. When this is set to "CONT.," printing starts and continues until the ink remaining inside the machine is used up. Regardless of the setting made for this menu item, we recommend replacing the ink cartridge immediately whenever a cartridge becomes empty.

Default Setting

[EMPTY MODE]: STOP

Setting the Interval until Activation of the Sleep Mode

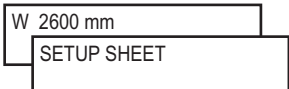
Procedure

-  Press .
Press  several times.
-  Press .
Press  several times.
-  Press  twice.
Use  and  to make the setting.
Press  to enable the setting.
-  Press .
Press  to go back to the original screen.

Default Setting

[INTERVAL]: 30min

Deactivating the Sleep Mode

Procedure

- 1**

MENU	◀◆
SUB MENU	▶

Press .
Press several times.
- 2**

SUB MENU	◀◆
SLEEP	▶

Press .
Press several times.
- 3**

SLEEP	◀◆
SETTING	▶

Press .
Press .
- 4**

SETTING	◀◆
ENABLE ▶ DISABLE	◀

Press .
Use and to select [DISABLE].
Press to enable the setting.
- 5**

W 2600 mm	
SETUP SHEET	

Press .
Press to go back to the original screen.

Default Setting

[SETTING]: ENABLE

Changing the Menu Language and the Units of Measurement

Procedure

- 1**

MENU LANGUAGE	◆
ENGLISH	↵

Hold down and switch on the sub power.
Use and to select the display (menu) language.
Press .
- 2**

LENGTH UNIT	◆
mm ▶ mm	↵

Use and to select the measurement unit for length.
Press .
- 3**

TEMP. UNIT	◆
°C ▶ °C	↵

Use and to select to the measurement unit for temperature.
Press .

Description

This sets the language and units of measurement displayed on the printer's screen.

Default Setting











[MENU LANGUAGE]: ENGLISH

[LENGTH UNIT]: mm

[TEMP. UNIT]: °C

Drying the Trailing Edge of the Printing Area on the Dryer

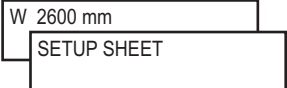
Procedure

- 1  Press .
Press  several times.
- 2  Press  twice.
Use   to select "ENABLE."
Press  to enable the setting.
- 3  Press .
Press  to go back to the original screen.

Description

When this menu item is set to "ENABLE," additional media feed is performed until the trailing edge of the printing area is positioned directly on the dryer. The margin between the print-end position and the next print-start position is fixed at 200 mm. Any margin setting made on the computer is ignored.







When this is set to "DISABLE," media feed stops simultaneously when printing ends. This means that the trailing edge of the printing area is not fed to the dryer unless you continue with a subsequent printing operation.

Default Setting

[FEED FOR DRY]: DISABLE

Returning All Settings to Their Initial Values

Procedure











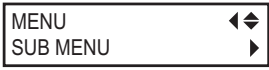

- 1  Press .
Press  several times.
- 2  Press .
Press  several times.
Press  to execute.

Description

This menu returns all settings to the same as their factory defaults. However, the settings for [LANGUAGE], [LENGTH UNIT] and [TEMP. UNIT] are not returned to the factory defaults.

Changing the Self-cleaning Settings

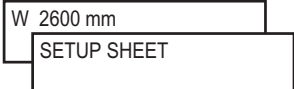
Procedure

- 1  Press  .
Press  several times.
- 2  Press  .
Press  several times.
- 3  Press  .
Use  and  to make the setting.
Press  to enable the setting.
- 4  Press  .
Press  to go back to the original screen.

Description

This sets the interval for performing cleaning automatically to prevent dry-out and clogging of the print heads (self-cleaning).

When this is set to "AUTO" (the default setting), the machine makes the determination automatically according to the ambient temperature and other factors.

When this is set to "** HOUR," self-cleaning is performed at the set interval.











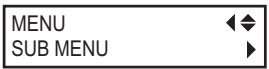



Depending on the ambient temperature, self-cleaning may be carried out more frequently than the interval set using "** HOUR." This is because on this machine, temperature control is given priority in order to protect the equipment.

Default Setting

[SELF CLEANING]: AUTO

Changing the Type of Ink

Procedure

- 1  Press  .
Press  several times.
- 2  Press  .
Press  several times.
- 3  Press  .
Press  .
- 4  Press  .
Use  and  to make the setting.
Press  to execute the setting.

Procedure

You use this when changing the type of ink. Selecting the type of ink used for replacement starts head-cleaning and ink-filling operations. Follow the on-screen instructions to insert and remove cartridges.

This operation requires six unused cleaning-fluid cartridges.

4-7 Changing the Ink-drying Method

Switching Off the Preheater, Print Heater, or Dryer

Procedure



Press **HEATER CONFIG** twice.
Use **◀** **▶** to select the device.
Press **▼** several times to select [OFF].
Press **ENTER** to enable the setting.

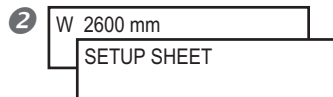

Press **MENU**.
Press **◀** to go back to the original screen.

Description

This makes the temperature settings for the media heating system (preheater, print heater, and dryer), as well as switching these devices on or off. When this is set to "OFF," these devices do not operate at all.

You can also make this setting on the computer. When you have made the setting on the computer, the computer's setting is used and the printer's setting is ignored.

Default Setting

[PRE] (preheater): 40°C (104°F)
[PRINT] (print heater): 40°C (104°F)
[DRYER]: 50°C (122°F)

Determining How the Media Heating System Operates

Procedure



Hold down **MENU** and press **HEATER CONFIG**.



Press **▼**.



Press **▶**.
Use **▲** **▼** to make the setting.
Press **ENTER** to enable the setting.

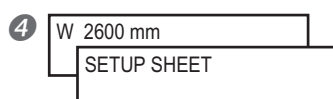

Press **MENU**.
Press **◀** to go back to the original screen.

Description



This makes the temperature setting for the media heating system when **SET UP** is dark. "MENU" performs heating to the preset temperature at all times, without lowering the temperature when **SET UP** is dark. A setting of "35°C" lowers the media heating system to a fixed temperature (35°C) when **SET UP** is dark. This temperature-setting cannot be changed. When the temperature is set at less than 35°C, however, the temperature is maintained at the set value. "OFF" switches off the media heating system when **SET UP** is dark.

Default Setting

[PREHEATING]: 35°C

Switching the Blower Fan On and Off

Procedure

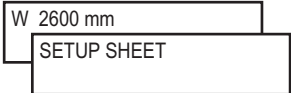
- 1  Hold down **MENU** and press **HEATER CONFIG**.
- 2  Press **▲**.
- 3  Press **▶**.
Use **▲** **▼** to make the setting.
Press **ENTER** to enable the setting.
- 4  Press **MENU**.
Press **◀** to go back to the original screen.

Description

The blower fan hastens ink-drying by blowing moving air onto the media on the drying heater. The force of the moving air cannot be adjusted. When this is set to "ON" (the default setting), the fan starts when media is loaded and the loading lever is engaged. Note, however, that when [DRYER] is set to "OFF," no operation starts when the loading lever is engaged. When this is set to "OFF," the blower fan does not operate, regardless of the [DRYER] setting or the state of the loading lever.



Default Setting

[BLOWER FAN]: ON

4-8 Recording the Amount of Remaining Media

Displaying the Amount of Remaining Media on the Screen

Procedure

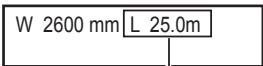
-  Press **MENU**.
Press **▲**.
-  Press **▶**.
Press **▼**.
-  Press **▶**.
Use **▲** and **▼** to set the amount of media remaining.
Press **ENTER** to enable the setting.
-  Press **MENU**.
Press **◀** to go back to the original screen.

The display is updated.



If setup has not been performed, the set value flashes.

Description



You can display how much of the media in use is left. Once you set the amount of media remaining, the amount remaining is displayed at the top menu until it reaches zero. If you cancel the setup such as by removing the media or raising the loading lever, the amount remaining at that time flashes on the screen.

The amount of media remaining is not updated automatically when you change the media. Redo the setting whenever you change the media. You can also make the setting to display this menu automatically whenever you change the media. See the next section "Verifying the Setting for the Amount Remaining Every Time the Media Is Changed."

* The remaining amount that is displayed is only an estimate, and its accuracy is not assured.

Verifying the Setting for the Amount Remaining Every Time the Media Is Changed

Procedure

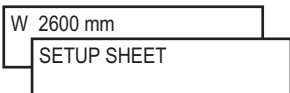
-  Press **MENU**.
Press **▲**.
-  Press **▶**.
Press **▲**.
-  Press **▶**.
Use **▲** and **▼** to select "ENABLE."
Press **ENTER** to enable the setting.
-  Press **MENU**.
Press **◀** to go back to the original screen.

Description

Setting this to "ENABLE" automatically displays [SHEET REMAIN] whenever you change the media and finish setup. This makes it impossible to go on to the next operation unless you redo the setting for the amount remaining. This can be useful for keeping you from forgetting to redo the setting when you change the media.









When you set this to "ENABLE," however, be sure to also set the [SHEET TYPE] menu item to "OPAQUE." When [SHEET TYPE] is set to "CLEAR," then [SHEET REMAIN] is not displayed automatically, regardless of the setting for [AUTO DISPLAY].

Default Setting

[AUTO DISPLAY] : DISABLE

Printing the Amount of Remaining Media

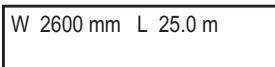
Procedure

- 1**  Press .
Press .
- 2**  Press .
Press  to perform printing.
- 3**  Press .
Press  to go back to the original screen.









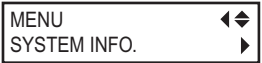

Description

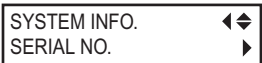
This prints the amount of media remaining that is displayed at the top menu. You use this when you want to make a record of the remaining length of the media now in use. Printing the amount of media remaining before you change the media enables you to refer to the printed record and use the value to make the setting for the remaining amount the next time you use the media.

4-9 Viewing System Information

Viewing the Serial Number, Firmware Version, and Other Information

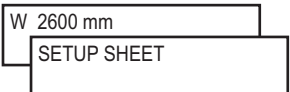
Procedure

-  Press  .
Press  several times.
-  Press  .
Use   to choose the information you want to view.
-  Press  .
-  Press  .
Press  to go back to the original screen.

Description

You can view the following information.

[MODEL]: model name









[SERIAL NO.]: serial number

[INK]: ink type

[FIRMWARE]: firmware version

Printing a System Report

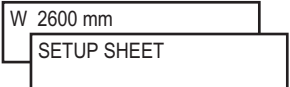
Procedure

-  Press  .
Press  several times.
-  Press  .
Press  several times.
Press  to start printing.
-  Press  .
Press  to go back to the original screen.

Description

This prints system information, including a list of setting values.

4-10 Menu List

Main menu

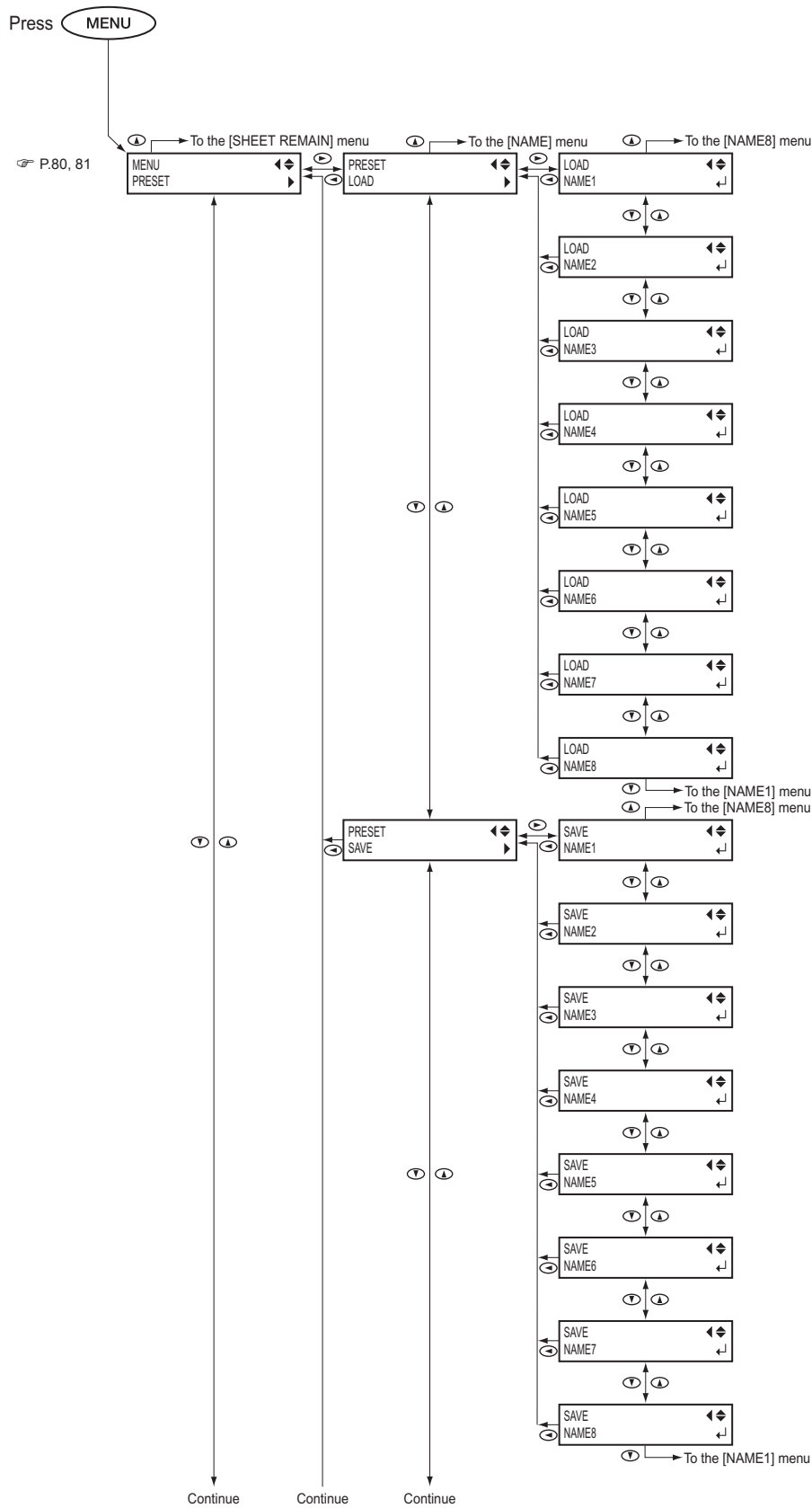

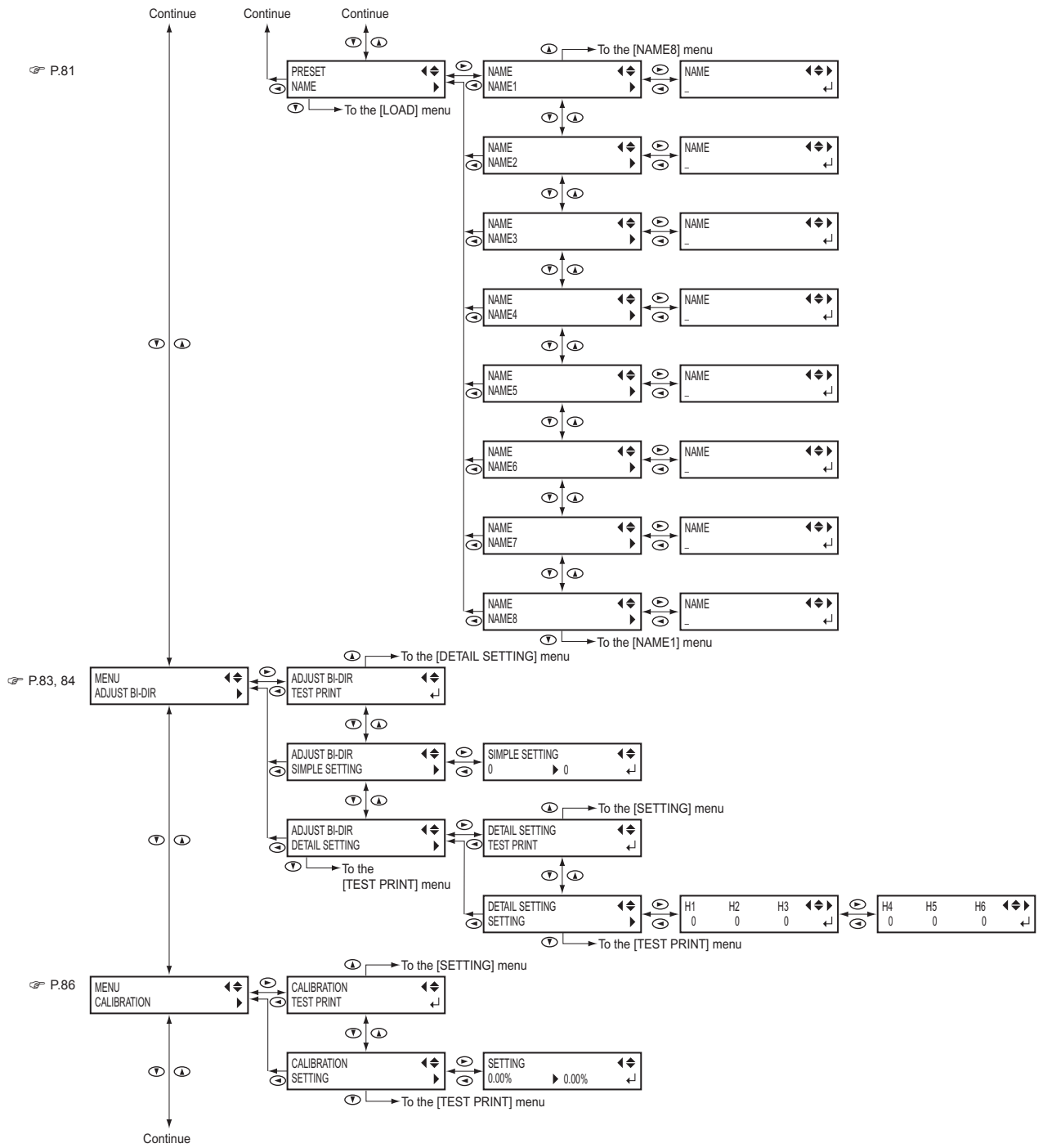

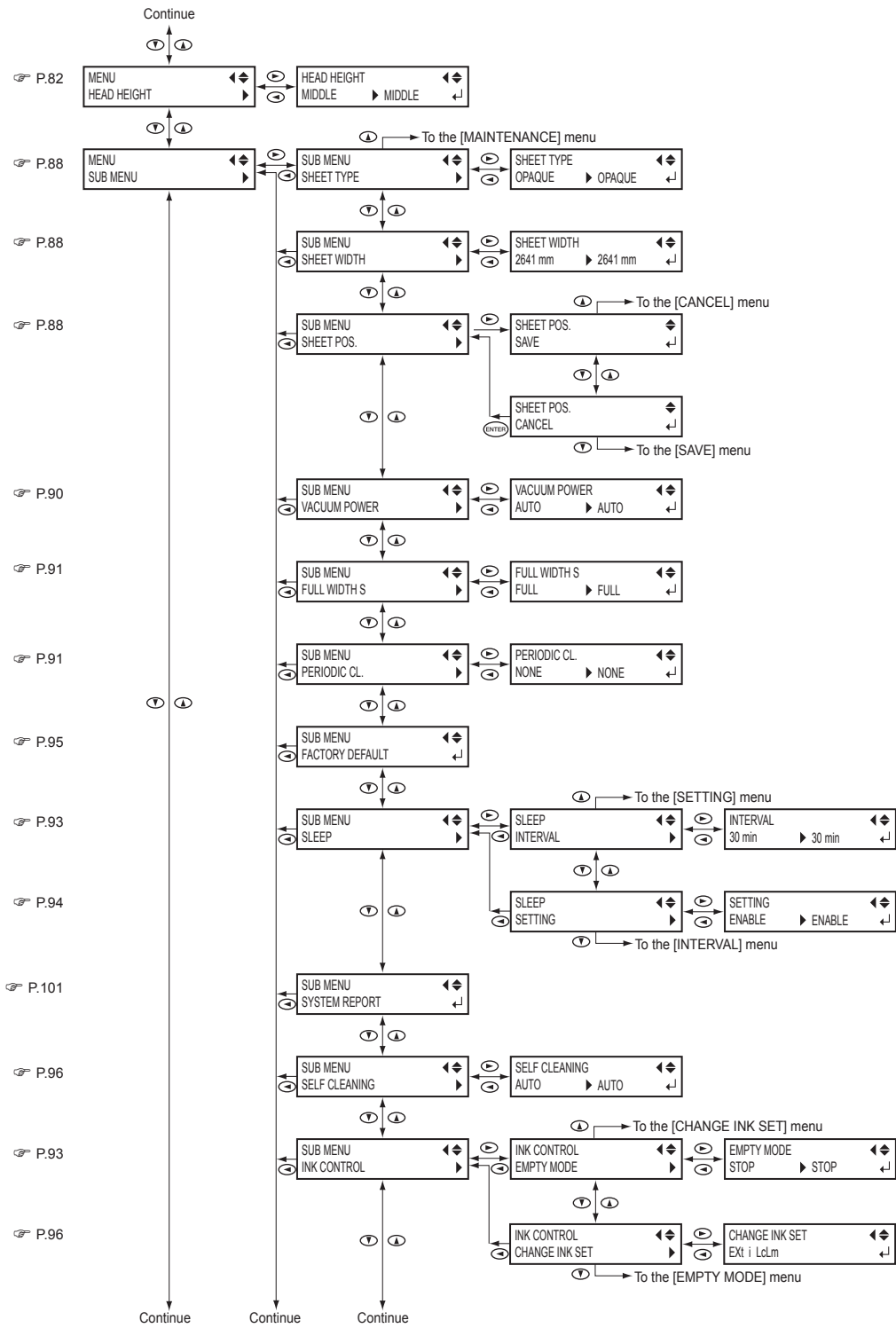

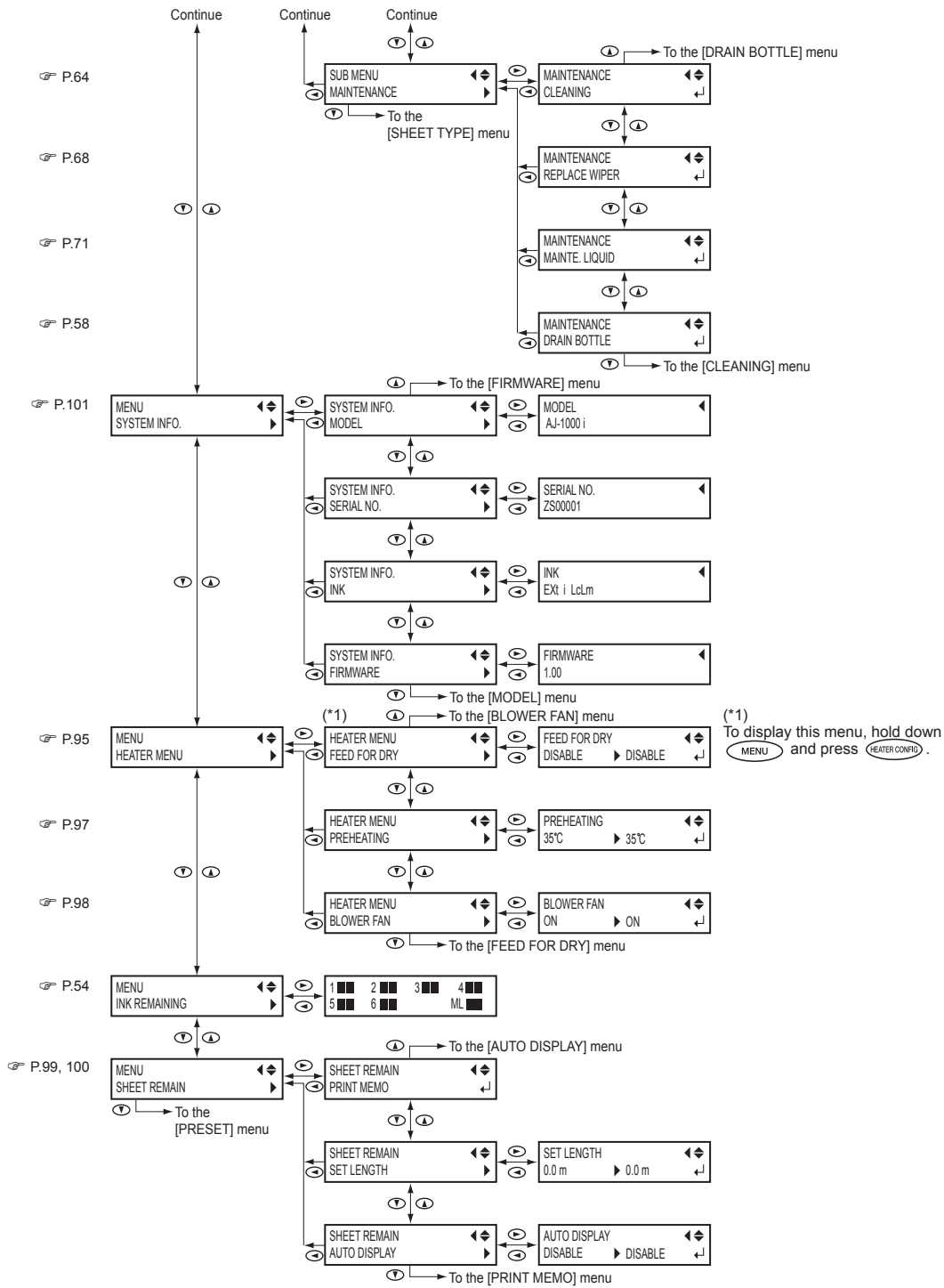

Language and Unit Menu

Hold down **MENU** and switch on the sub power.

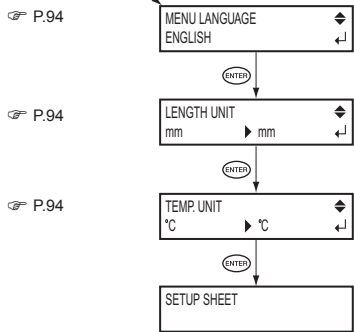

Cleaning Menu

Press **CLEANING**

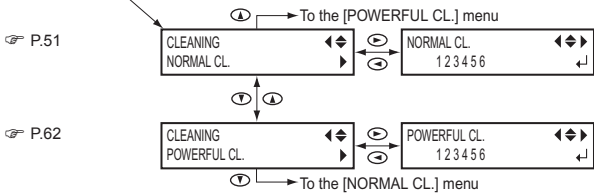

Hold down **CLEANING** for one second or longer

P.52 (Cleaning for all heads starts)

Media Heating System Configuration Menu

Press **HEATER CONFIG**

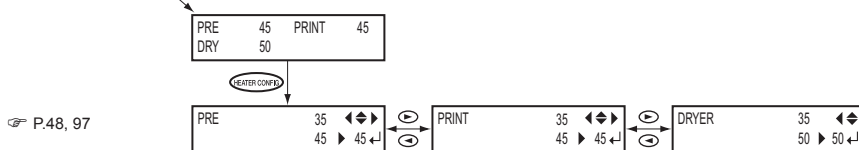

P.48, 97

Chapter 5

What to Do If

5-1 The Machine Doesn't Run

The Printer Unit Doesn't Run

Is the power switched on?

Switch on the printer's main power, then press the sub power switch and make sure the sub power switch lights up.

Is **SET UP** illuminated?

Printing is not performed when **SET UP** is not illuminated. Pull back the loading lever, close the front cover, and press **SET UP**.

Is the front cover open?

Close the front cover.

Is the top menu displayed?



If the top menu isn't displayed, printing doesn't start even when data is sent from the computer. To go to the top menu, press **MENU**, then press **◀**.

Is **PAUSE** illuminated?

When **PAUSE** lights up, operation is paused. To resume, press **PAUSE**. **PAUSE** goes dark and printing resumes.

Has ink run out?



If a warning beep sounds and the screen shown in the figure appears, the ink cartridge indicated by the flashing number is empty. Replace it with a new ink cartridge.

At the [EMPTY MODE] menu, you can make the setting that determines whether printing starts when the printer receives printing data while an ink cartridge is empty.

☞ P.93, "Determining What Happens When an Ink Cartridge Is Empty"

Is a message displayed on the screen?

☞ P.115, "If a Message Appears"

☞ P.116, "If an Error Message Appears"

Is the power cord connected?

Connect the power cord securely.

The Media Take-up or Feed System Doesn't Run

Is the power switched on?

Switch on both the printer's main power switch and the power switch for the take-up and feed units. To perform take-up and feed automatically during printing, also make the setting for the AUTO switch.

Is the cover closed securely?

The take-up and feed units do not operate unless the cover is securely closed.

Is media loaded correctly?

Make sure the media is passed through the guide roller and dancer rollers correctly.

The Dryer Doesn't Warm Up

Is the main power switch for the dryer turned on?

Turn on the main power switch for the dryer.

Is the dryer's power cord connected?

Connect the power cord securely.

Is media loaded?

The dryer does not warm up to the preset temperature when **SET UP** is dark (unless the default setting has been changed). Load media, press **SET UP**, and wait for the machine to warm up.

☞ P.97, "Determining How the Media Heating System Operates"

Is the temperature of the room too low?

Use the machine in an environment where the temperature is 20 to 32°C (68 to 90°F).

Is the power supply the right voltage?

This machine requires 200 to 240 V power. Please note that it will not operate correctly at a lower voltage.

The Preheater and Print Heater Don't Warm Up

Is media loaded?

The preheater and print heater do not warm up to the preset temperature when **SET UP** is dark (unless the default setting has been changed). Load media, press **SET UP**, and wait for the machine to warm up.

☞ P.97, "Determining How the Media Heating System Operates"

Is the temperature of the room too low?

Use the machine in an environment where the temperature is 20 to 32°C (68 to 90°F).

Is the power supply the right voltage?

This machine requires 200 to 240 V power. Please note that it will not operate correctly at a lower voltage.

5-2 Attractive Printing Is Impossible

Printed Results Are Coarse or Contain Horizontal Stripes

Do the print heads show dot drop-out?

Carry out a printing test and make sure no dot drop-out occurs. If dot drop-out is present, perform head cleaning.

☞ P.51, "Printing Tests and Cleaning"

☞ P.62, "When Head Cleaning Is Not Effective"

Have you carried out feed correction?

Large misalignment in the amount of feed of the media may result in printing that seems coarse or contains horizontal stripes. Either make the setting on the computer to match the type of media you're using, or make the setting for correction on the printer.

☞ P.86, "Performing Feed Correction to Alleviate Horizontal Bands and the Like"

Have you carried out bidirectional correction?

When you are performing bidirectional printing, use the [ADJUST BI-DIR] menu item to carry out correction. The optimal adjustment value may vary, depending mainly on the thickness of the media. Set or select an adjustment value that is suited to the media.

☞ P.83, "Correcting for Misalignment in Bidirectional Printing"

Is the media heating system at a suitable temperature?

If the ink forms lumps or smudges, raise the temperature. Note, however, that a temperature that is too high may degrade the media or cause it to wrinkle.

☞ P.48, "Making the Temperature Settings for the Media Heating System"

Is the temperature of the room too low?

The media heating system may not warm up sufficiently when the temperature is 20°C (68°F) or lower. Also, even when the media heating system reach their preset temperatures, adequate effectiveness may not be apparent if the media is thoroughly chilled. Before printing, allow the media to come to room temperature.

Is the print mode suitable?

If attractive printing is impossible even when the print heater, preheater, and dryer are at a high temperature, try using a higher-quality print mode.

Depending on the media, smudging may occur when using a high-quality print mode, and results may also vary greatly depending on the settings of your RIP program (such as the color-profile selection). Make settings suited to the media you're using.

Is the printer installed in a level and stable location?

Never install the machine in a location where it is tilted or where it may wobble or experience vibration. Also make sure that the

print heads are not exposed to moving air. These factors may lead to missing dots or reduced printing quality.

Is the media loaded and set up correctly?

If the media is not loaded and set up correctly, media feed may not be smooth, or printing may be adversely affected.

☞ P.113, "Media Wrinkles or Shrinks, or Feed Is Unstable"

Are the settings for the [PRESET] menu item appropriate?

If the settings selected with the [PRESET] menu item are not suitable for the type of media, printing may be adversely affected. Choose settings optimized to the media you're using.

☞ P.80, "Saving Optimized Media Settings As Preset Values"

☞ P.81, "Loading a Saved Preset"

Colors Are Unstable or Uneven

Is the media wrinkled?

If the media is wrinkled and comes loose from the platen, colors may be uneven or printing reduce may suffer.

☞ P.113, "Media Wrinkles or Shrinks, or Feed Is Unstable"

Was printing paused partway through?

When printing is paused, the coloring at the seam may be altered when printing resumes. Avoid pausing printing. Printing pauses when ink remaining inside the machine runs out. Before you perform lengthy printing, check the amount of ink remaining in the ink cartridges, and immediately replace any cartridge that becomes empty.

Printing may also pause when data is not sent from the computer quickly enough. We recommend not performing any other tasks with the computer while printing is in progress.

Are the operating parameters set to appropriate values?

Depending on the settings for such menu items as [FULL WIDTH S] and [PERIODIC CL.], uneven colors may occur. If the settings have been changed, try restoring them to their default values.

☞ P.91, "Speeding Up Printing for Narrow Media"

☞ P.91, "Keeping Media from Being Soiled by Ink Drips"

Is the printer installed in a level and stable location?

Never install the machine in a location where it is tilted or where it may wobble or experience vibration. Also, ensure that the printing heads are not exposed to wind or blown air. These factors may lead to missing dots or reduced printing quality.

Are the settings for the [PRESET] menu item appropriate?

If the settings selected with the [PRESET] menu item are not suitable for the type of media, printing may be adversely affected. Choose settings optimized to the media you're using.

☞ P.80, "Saving Optimized Media Settings As Preset Values"

☞ P.81, "Loading a Saved Preset"

The Media Becomes Soiled When Printed

Do the print heads contact the media?

The height of the print heads may be too low. Also, if the media is not loaded and set up correctly, it may wrinkle or come loose and strike the heads.

☞ P.113, "Media Wrinkles or Shrinks, or Feed Is Unstable"

☞ P.82, "Adjusting Head Height to Match Media Thickness"

Are the print heads dirty?

The following may cause ink to drip on the media during printing.

- Buildup of fibrous dust (lint) around the heads
- Ink transferred to the heads due to rubbing against the media.

If this happens, clean the heads using the cleaning kit. We recommend carrying out periodic head cleaning.

☞ P.64, "Cleaning the Heads Using the Cleaning Kit"

Are the pinch rollers dirty?

Periodically clean the pinch rollers.

5-3 The Media Jams

The Media Jams

If an error message is displayed because the media has jammed, immediately correct the problem. Failure to do so may damage the print heads.

☞ P.116, [MOTOR ERROR CAP PRINT HEADS]

☞ P.116, [MOTOR ERROR TURN POWER OFF]

Is the media warped or wrinkled?

Many factors can cause warping or wrinkling. Refer to the following and correct the problem.

☞ P.113, "Media Wrinkles or Shrinks, or Feed Is Unstable"

Is the height of the print heads too low?

Try raising the heads higher. Media may inevitably warp or wrinkle slightly, so adjust the height of the heads to take this into account.

☞ P.82, "Adjusting Head Height to Match Media Thickness"

Are the media clamps installed with the left and right sides oriented correctly?

The media clamps have distinct left and right sides. Make sure of the orientation and install correctly.

☞ P.44, Procedure 7 on "How to Load Media"

5-4 The Media Cannot Be Taken Up Smoothly

The Media Cannot Be Taken Up Smoothly

Is media feed unstable?

Various factors can make media feed unstable. Refer to the following and correct the problem.

☞ P.113, "Media Wrinkles or Shrinks, or Feed Is Unstable"

5-5 Media Wrinkles or Shrinks, or Feed Is Unstable

A variety of problems can occur if the media feed is not smooth. This can cause such problems as poor printing quality, contact with the media by the print heads, misaligned positioning, media jams, or poor take-up. Take action as follows.

Media Wrinkles or Shrinks

Is the media loaded and set up straight and securely?

Feed is not smooth when the media is not straight or tensioned unevenly on the left and right. Reload the media.

Is the feed dancer roller level?

If it is not level, the media may become crooked or wrinkle. Reload the media using the media gauge.

Is media loaded correctly?

Make sure the media is passed through the guide roller and dancer rollers correctly.

Is the positioning of the loaded media displaced to the left or right?

Smooth feed is not possible when the positioning of the loaded media is displaced to the left or right. Reload the media using the media gauge.

Was loaded media allowed to stand for some time?

Media may shrink or wrinkle if it is heated for an extended time. When printing ends, switch off the sub power or remove the media.

Was the media loaded while the media heating system is hot?

Loading media after the media heating system has warmed up causes the temperature of the media to rise suddenly, which may cause the media to shrink or wrinkle during printing. Before loading media, switch off the sub power and allow them to cool.

Is the temperature of the media heating system too high?

Set the temperature to suitable values for the type of media.

☞ P.48, "Settings of the Media Heating System"

Is the roll media sagging?

Sagging of the roll can cause wrinkling or warping. When loading media, be sure to install the reinforcement pipe. Also, when storing media, place it so that it will not sag under its own weight.

☞ P.32, "How to Load Media"

The Media Is Not Straight

Is the media loaded and set up straight and securely?

Feed is not smooth when the media is not straight or tensioned unevenly on the left and right. Reload the media.

Is the feed dancer roller level?

If it is not level, the media may become crooked or wrinkle. Adjust the position of the balance weights to match the width of the media.

Is media loaded correctly?

Make sure the media is passed through the guide roller and dancer rollers correctly.

Is the positioning of the loaded media displaced to the left or right?

Smooth feed is not possible when the positioning of the loaded media is displaced to the left or right. Reload the media using the media gauge.

Media Feed Is Not Smooth

Do the media or the dancer rollers strike some other object?

Make sure the media and the dancer rollers do not touch anything else. This may affect printing, even when feed appears to be smooth.

Is the media too thick?

Media that is too thick may not only cause unstable feed, but may scrape the print heads, resulting in malfunction. Never use such media.

Are the grit rollers dirty?

Check to make sure the grit rollers are free of buildup of foreign material such as media scraps.

5-6 The Print Heads Stopped Moving

If the print-head carriage stops over the platen, take action immediately to prevent the heads from drying out.

What to Do First

If the message [MOTOR ERROR CAP PRINT HEADS] appears, first eliminate the cause of the error, then press **ENTER**. When the print-head carriage has moved to the standby position (inside the right side cover), switch off the sub power.

If the print-head carriage doesn't move, switch the sub power off, then back on again. (If the media is jammed, then remove the media as well.)

If the print-head carriage still doesn't move, try switching off the main power, then switching on first the main power, then the sub power.

If the Heads Still Do Not Move

If the heads still do not move, carry out the following emergency response measure, then contact your authorized Roland DG Corp. dealer.

1. Switch off the main power and detach the right side cover.
2. Open the front cover.
3. Gently move the cap unit by hand to the position shown in the figure.

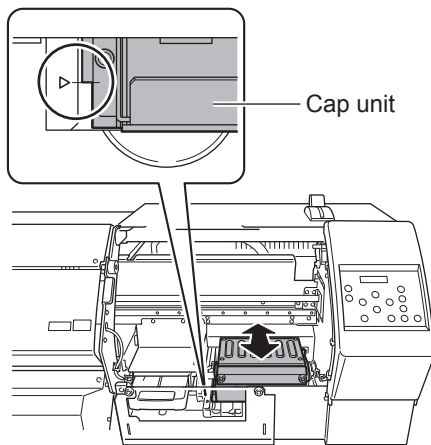

4. Gently move the print-head carriage by hand as far as the standby position.

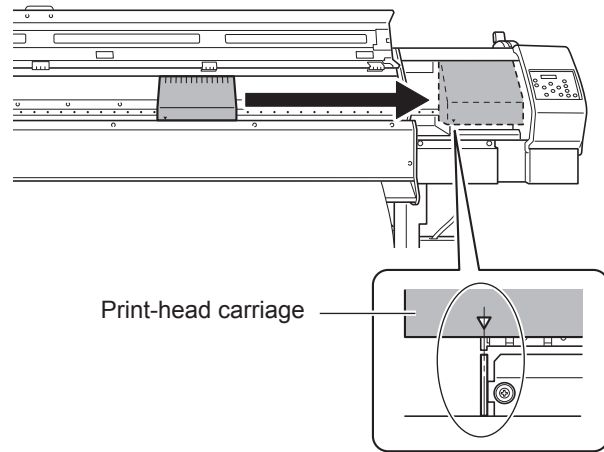

5. Insert the head-unit tool into the hole on the bottom of the machine and turn gently. The print heads descend.

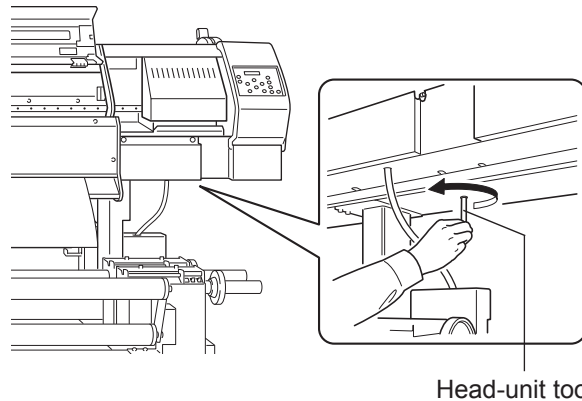

6. Make the guides at the edges of the print heads line up with the guides at the edges of the cap unit. Turn the tool further to bring the print heads near the cap unit.

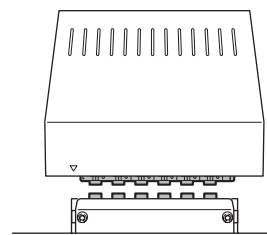

7. When the print heads make contact with the cap unit, turn the tool three more turns.

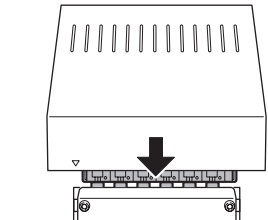

Make sure the print heads are capped tightly.

5-7 If a Message Appears

These are the main messages that appear on the machine's display to prompt correct operation. They do not indicate any error. Follow the prompts and take action accordingly.

[1 ■ 2 ■ 3 ■ 4 ■ ...]

Only a small amount of ink remains. Replace the cartridge indicated by the flashing number with a new cartridge.

[CHECK DRAIN BOTTLE]

This appears when a certain amount of discharged fluid collects in the drain bottle. To clear the message, press **ENTER**. If this screen appears, go to the [DRAIN BOTTLE] menu and discard the discharged fluid in the bottle.

☞ P.58 "Disposing of Discharged Ink"

[CLOSE SLOT COVER]

Close the cartridge-slot cover. This appears if the cover is open when the printer receives printing data. Printing starts when the cover is closed.

[CLOSE THE COVER (RIGHT SIDE COVER/FRONT COVER)]

Close the right side cover, the front cover, or both. For safety, the carriage does not operate while a cover is open.

[DO NOT USE MEDIA CLAMPS]

Make sure the media clamps have been removed. The media clamps cannot be used when the height of the print heads is set to "LOW." (Using them may cause malfunction.) After verifying, press **ENTER**.

[INSTALL DRAIN BOTTLE]

Check whether the drain bottle is installed. Install the drain bottle, then press **ENTER**.

[NOW HEATING...]

Wait until the preheater, print heater and dryer reach the preset temperature. Printing starts when **HEATER CONFIRM** lights up.

You can stop printing by holding **SET UP** for one second or longer while this is displayed. Pressing **PAUSE** makes printing start immediately, without waiting to reach the preset temperature.

[NOW WARMING UP]

Wait until the message disappears. Printing cannot be started until the message disappears. Holding down **SET UP** for one second or longer while this message is displayed quits printing.

[SHEET NOT LOADED PRESS SETUP KEY]

Load media and press **SET UP**. This message appears when an attempt to perform a printing test was made while no media was loaded.

[SET CARTRIDGE]

Insert the ink cartridge indicated by the flashing number. This message appears at times such as during cartridge replacement.

[SET HEAD HEIGHT TO ***, SURE?]

This appears when the height of the print heads is higher than the head height set on the computer. Pressing **ENTER** changes the head height to the computer's setting and starts printing. Pressing **▶** lets you set the head height without change.

[TIME FOR MAINTENANCE]

It is time to clean the heads using the cleaning kit. After verifying, press **ENTER**.

☞ P.64, "Cleaning the Heads Using the Cleaning Kit"

[TIME FOR WIPER REPLACE]

It is time to replace the wiper. After verifying, press **ENTER**.

☞ P.68, "Replacing the Wipers"

5-8 If an Error Message Appears

This describes the error messages that may appear on the machine's display, and how to take action to remedy the problem. If the action described here does not correct the problem, or if an error message not described here appear, contact your authorized Roland DG Corp. dealer.

[AVOIDING DRY-UP TURN POWER OFF]

The print heads were forced to standby position to prevent them from drying out.

Operation cannot be continued. Switch the sub power off, then back on. Opening the front cover while printing is in progress causes an emergency stop. Never allow the print heads to stand in this state.

[CANCELED FOR WIPER PROTECTION]

Operation stopped because the maintenance liquid has run out completely.

Press **ENTER** clears the error message, but printing cannot be executed. Execute the printer's [MAINTE. LIQUID] menu item and replace the maintenance liquid cartridge with a new one. If the machine is allowed to stand with the error uncorrected, the print heads may dry out and become damaged.

☞ P.71, "Replacing the Maintenance Liquid Cartridge"

[CHECK THE FEED UNIT]

The feed system stopped without feeding out any media.

If media has run out, stop printing and load new media.

[DATA ERROR CANCELING...]

Output was stopped because a problem was found in the data received.

Operation cannot be continued. Check for problems with the connector cable or the computer, then redo the operation, starting with reloading the media.

[FEED UNIT LOCKED]

Printing stopped automatically because the feed system stopped.

Press **ENTER** to clear the error message. Eliminate the cause that made the feed system stop, then carry out the next printing operation.

[HEATING TIMEOUT CONTINUE?]

The preheater or print heater did not reach the preset temperature.

This occurs because the temperature of the location where the machine is installed is too low. We recommend raising the

temperature. To quit printing, hold down **SET UP** for one second or longer. To continue waiting for the temperature to rise, press **ENTER**. To start printing immediately, press **PAUSE**.

[MOTOR ERROR CAP PRINT HEADS]

A motor error occurred.

Eliminate the cause of the error, then press **ENTER**. The heads move to the standby position. After the heads have moved, switch off the sub power. If the machine is allowed to stand with the error uncorrected, the print heads may dry out and become damaged.

This error may be caused by such factors as a mistake in loading the media, a media jam, or an operation that pulls the media with excessive force.

The media is loaded incorrectly.

Check how the media is threaded through the rollers. Also make sure the AUTO switches for the feed and take-up units are set correctly.

The media has jammed.

Carefully remove the jammed media. The print heads may also be damaged. Perform head cleaning, then perform a printing test and check the results.

The media was pulled with excessive force.

Excessive tension was applied to the media, and additional action is necessary to recover from this state. First, move the loading lever to the rear and open the cover for the feed and take-up units. Adjust the media to create a small amount of slack, then switch on the sub power.

[MOTOR ERROR TURN POWER OFF]

A motor error occurred.

Operation cannot be continued. Switch off the sub power. Next, eliminate the cause of the error, then immediately switch on the sub power. If the machine is allowed to stand with the error uncorrected, the print heads may dry out and become damaged. This error may be caused by such factors as a mistake in loading the media, a media jam, or an operation that pulls the media with excessive force.

The media is loaded incorrectly.

Check how the media is threaded through the rollers. Also make sure the AUTO switches for the feed and take-up units are set correctly.

The media has jammed.

Carefully remove the jammed media. The print heads may also be damaged. Perform head cleaning, then perform a printing test and check the results.

The media was pulled with excessive force.

Excessive tension was applied to the media, and additional action is necessary to recover from this state. First, move the loading lever to the rear and open the cover for the feed and take-up units. Adjust the media to create a small amount of slack, then switch on the sub power.

[NO MAINTENANCE LIQUID]**The maintenance liquid cartridge is empty.**

Press **ENTER** to clear the error message. Execute the printer's [MAINTENANCE LIQUID] menu item and replace the maintenance liquid cartridge with a new one. If the machine is allowed to stand with the error uncorrected, the print heads may dry out and become damaged.

☞ P.71, "Replacing the Maintenance Liquid Cartridge"

[PINCHROLL ERROR LOWER PINCHROLL]****SET UP** was pressed without first lowering the pinch rollers.**

Press any key to clear the error. Pull back the loading lever, then press **SET UP**.

The pinch rollers were raised while **SET UP was illuminated.**

The error is cleared automatically after a short wait. Never move the loading lever while printing is in progress.

[SERVICE CALL xxxx]**An unrecoverable error occurred, or part replacement that must be performed by a service technician is required.**

Note the number displayed, then switch off the sub power. After you switch off the power, inform your authorized Roland DG Corp. dealer of the number that appeared on the display.

[SHEET SET ERROR SET AGAIN]****SET UP** was pressed even though no media is loaded.**

Press any key to clear the error. Load media and pull back the loading lever, then press **SET UP**.

Transparent media was loaded even though [SHEET TYPE] is set to "OPAQUE."

Press any key to clear the error. Set the [SHEET TYPE] menu item to "CLEAR," then reload the media.

☞ P.88, "Using Transparent Media"

The positioning of the loaded media is displaced to the left.

Press any key to clear the error. Reload the media at the correct position, then press **SET UP**.

The platen is dirty.

Press any key to clear the error. The machine cannot sense the width of the media because of soiling. Clean the platen.

[TEMPERATURE IS TOO HIGH]**The temperature of the location where the machine****is installed has risen above the ambient temperature at which the machine can operate.**

Operation cannot be continued. Switch off the sub power. Bring the installed location to a temperature at which operation is possible (20 to 32°C) and allow the machine to come to room temperature, then turn on the power.

[TEMPERATURE IS TOO LOW]**The temperature of the location where the machine is installed has fallen below the ambient temperature at which the machine can operate.**

Operation cannot be continued. Switch off the sub power. Bring the installed location to a temperature at which operation is possible (20 to 32°C) and allow the machine to come to room temperature, then turn on the power.

[WRONG CARTRIDGE]**A cartridge that cannot be used was installed.**

Remove the cartridge to clear the error. Use a cartridge of the specified type.

[WRONG WIDTH UNDER 1220mm (or 48")]**The width of the loaded media is too narrow.**

Press **ENTER** to clear the error. Note, however, that performing printing without making any changes causes the media to be fed incorrectly, which may result in malfunction or damage to the machine. Replace with media of usable size.

Chapter 6

Specifications

6-1 Usable Media

Conditions for Usable Media

Media width

AJ-1000i: 1,220 to 2,641 mm (48 to 104 inches)

AJ-740i: 1,220 to 1,910 mm (48 to 75 inches)

Roll outer diameter (A)

Maximum 250 mm (9.8 inches)

Paper tube (core) inner diameter (B)

76.2 mm (3 inches)

Media thickness (C)

Maximum 1.0 mm (39 mil)

Roll weight

Maximum 100 kg (220 lb.)

Other conditions

Media such as the following cannot be used.

- Media whose end is attached to the paper tube (core)
- Media which is severely warped or which has a strong tendency to reroll
- Media that cannot withstand the heat of the media heating system
- Media that cannot withstand the tensioning of the media take-up or feed system
- Media whose paper tube (core) is bent or crushed
- Media that bends under its own weight when loaded

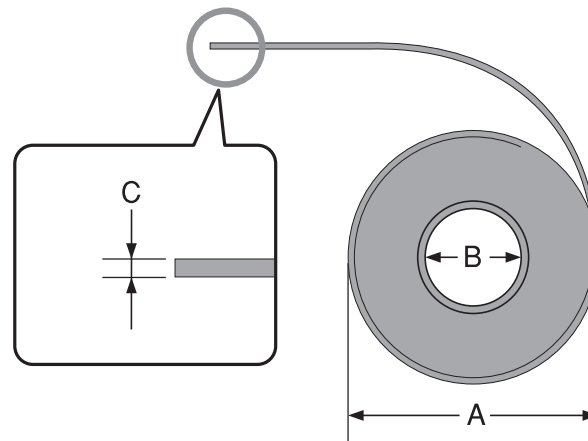

This machine cannot necessarily print every kind of media. When selecting media, be sure to carry out testing in advance to make sure that satisfactory printing quality is obtained.

6-2 Printing Area

Printing Area and Margins

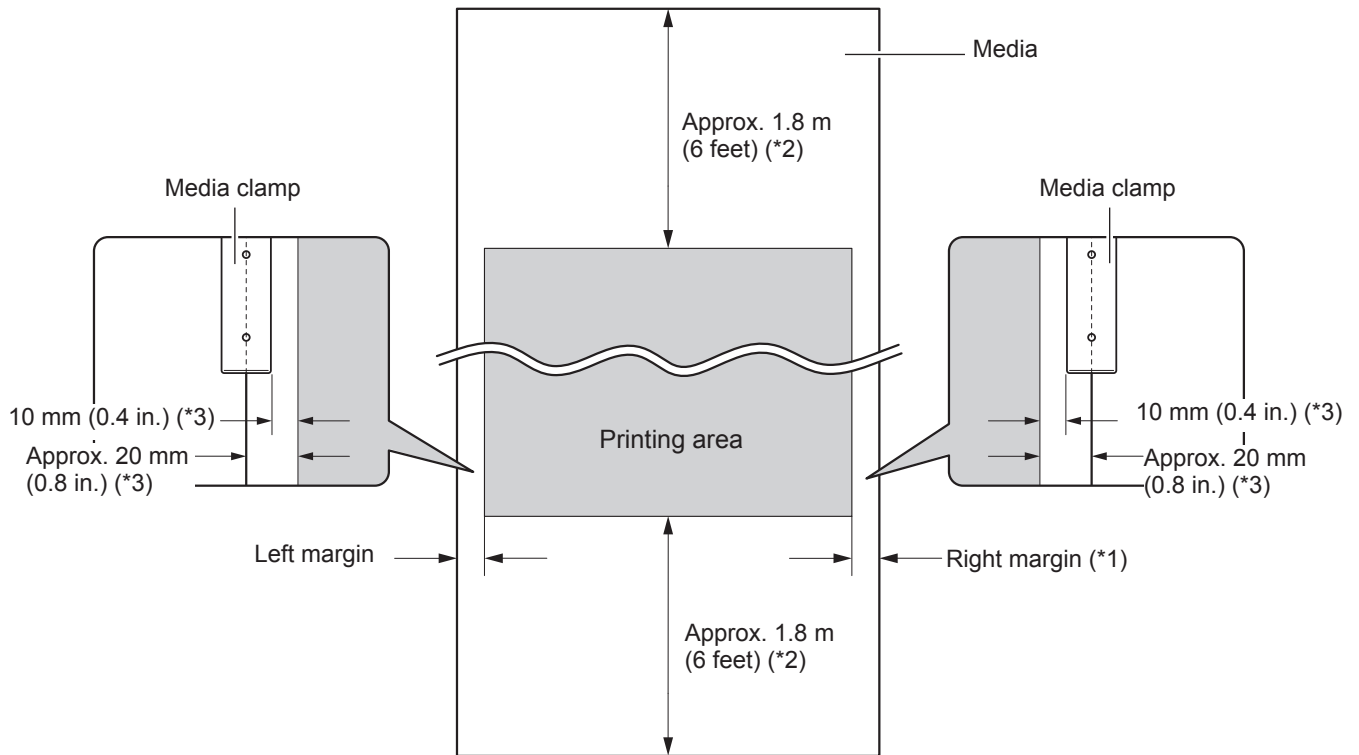

*1 The amount of margin can be changed by using **BASE POINT**.

*2 Margin length required by the media take-up and feed systems.

*3 Margin set automatically (default value; for media whose width is detectable)

6-3 Locations of the Power Rating and Serial Number Labels

Serial Number

This is required when you seek maintenance, servicing, or support. Never peel off the label or let it get dirty.

Power Rating

Use an electrical outlet that meets the requirements for voltage, frequency, and amperage given here.

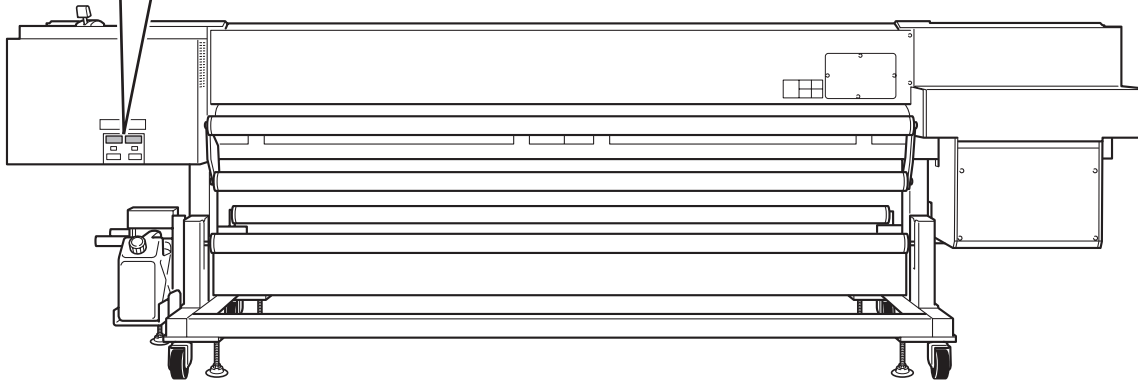

6-4 Specifications

		AJ-1000i	AJ-740i
Printing method		Piezo ink-jet method	
Loadable media width		1,220 to 2,641 mm (48 to 104 in.)	1,220 to 1,910 mm (48 to 75.2 in.)
Printable area		Maximum width: 2,600 mm (102.3 in.)	Maximum width: 1,870 mm (73.6 in.)
Ink	Type	EcoXtreme i, EcoXtreme LT Ink	
	Colors	6 colors (cyan, magenta, yellow, black, light-cyan, and light-magenta)	
Resolution		Maximum 720 dpi	
Printing speed		Maximum approx. 45 m ² /h	Maximum approx. 44 m ² /h
Distance accuracy(*1)		Error of less than ±0.3% of distance traveled, or 0.3 mm, whichever is greater	
Media take-up system	Roll outer diameter	Maximum 250 mm (9.8 in.)	
	Roll weight	Maximum 100 kg (220 lb.)	
Media feed system	Roll outer diameter	Maximum 250 mm (9.8 in.)	
	Roll weight	Maximum 100 kg (220 lb.)	
Media dryer(*2)		Heating method (Used in combination with the blower fan), setting range for the preset temperature: 35 to 60°C (95 to 140°F)	
Ink-fixing device(*2)		Preheater and print heater, setting range for the preset temperature: 30 to 50°C (86 to 122°F)	
Interface		Ethernet (10BASE-T/100BASE-TX, automatic switching)	
Power-saving function		Automatic sleep	
Power supply	Voltage and frequency	Printer unit: AC 200 to 240 V ±10%, 50/60 Hz Dryer: AC 200 to 240 V ±10%, 50/60 Hz	
	Required power capacity	Printer unit: 10 A, Dryer: 10 A	Printer unit: 8.5 A, Dryer: 8.5 A
Power consumption	During operation	Printer unit: Approx. 1,600 W Dryer: Approx. 2,300 W	Printer unit: Approx. 1,190W Dryer: Approx. 1,620 W
	Sleep mode	Approx. 60 W	
Acoustic noise level	During operation	70 dB (A) or less	
	During standby	40 dB (A) or less	
Dimensions		4,299 (W) x 1,115 (D) x 1,413 (H) mm (169.3 (W) x 43.9 (D) x 55.7 (H) in.)	3,632 (W) x 1,115 (D) x 1,359 (H) mm (143 (W) x 43.9 (D) x 53.5 (H) in.)
Weight		598 kg (1,319 lb.)	478 kg (1,050 lb.)
Environment	Power on (*3)	Temperature: 20 to 32°C (68 to 89.6°F), humidity: 35 to 80% (no condensation)	
	Power off	Temperature: 5 to 40°C (41 to 104°F), humidity: 20 to 80% (no condensation)	
Included items		Power cords, roll shafts, end caps, spacers, media reinforcement pipe, paper tube, drain bottle, media gauge, media clamps, hexagonal wrenches, Head-unit tool, cleaning kit, syringe, tube, maintenance liquid cartridge, software RIP, Roland-PrintServer CD-ROM, User's Manual, Setup Guide, Roland-PrintServer Network Settings Guide	

*1

○ At Roland PET film, print travel: 1 m

○ Temperature: 20°C (68°F), humidity: 50%

○ Not assured when the media heating system is used.

*2

○ Warm-up is required after powerup. This may require 5 to 20 minutes, depending on the operating environment.

○ Depending on the ambient temperature and media width, the preset temperature fail to be reached.

6-4 Specifications

*3

Environment

