

MODEL APRO II

AUTOMATIC TOOL CHANGER

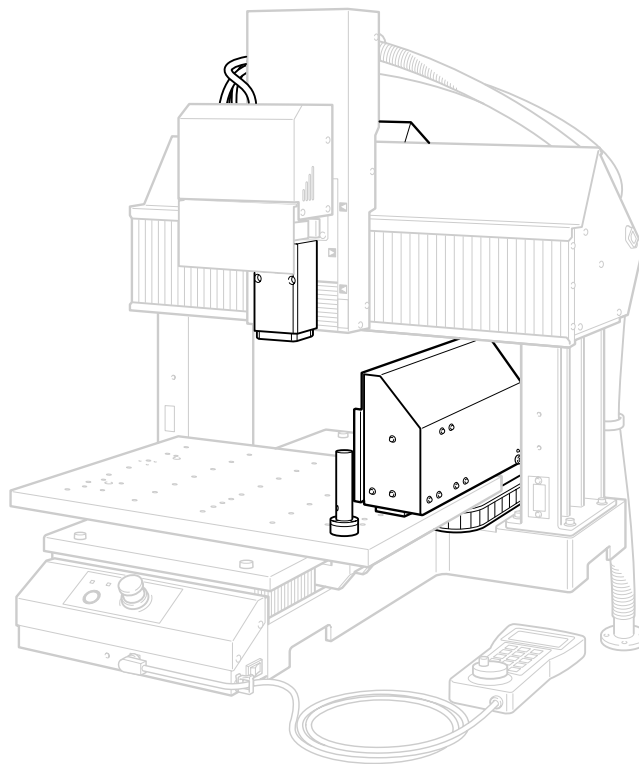

ZAT-540 USER'S MANUAL



Thank you very much for purchasing this product.

- To ensure correct and safe usage with a full understanding of this product's performance, please be sure to read through this manual completely and store it in a safe location.
- Unauthorized copying or transferral, in whole or in part, of this manual is prohibited.
- The contents of this operation manual and the specifications of this product are subject to change without notice.
- The operation manual and the product have been prepared and tested as much as possible. If you find any misprint or error, please inform us.
- Roland DG Corp. assumes no responsibility for any direct or indirect loss or damage which may occur through use of this product, regardless of any failure to perform on the part of this product.
- Roland DG Corp. assumes no responsibility for any direct or indirect loss or damage which may occur with respect to any article made using this product.

Contents

 To Ensure Safe Use	4
 Pour utiliser en toute sécurité	12
Important Notes on Handling and Use	21
Chapter 1 Introduction	23
1-1 Introduction	24
Features	24
Installable Model	24
Organization of the Documentation	24
1-2 Names and Functions	25
External View	25
VPanel	26
Chapter 2 Installation	27
2-1 Before Installing	28
Checking the Included Items	28
Preparing the Compressed-air Source	29
Preparing the Tool Holders	30
Overview of the Installation Procedure	31
Required Setup Operations for the MDX-540A (ATC-equipped Model)	31
2-2 Step 1: Attach the Control Box	32
Attach the Control Box	32
2-3 Step 2: Attach the Magazine Unit	33
For a Standard Table	33
For a T-slot Table	36
2-4 Step 3: Attach the Spindle and Cylinder	39
Attach the Spindle and Cylinder	39
2-5 Step 4: Connect and Secure the Cables	42
Connect and Secure the Cables	42
2-6 Step 5: Supply Compressed Air	45
Supply Compressed Air	45
2-7 Step 6: Adjust the Tool-change Location	46
Adjust the Tool-change Location	46
Chapter 3 Basic Operation	49
3-1 Starting and Quitting	50
How to Start the Machine	50
How to Shut down	51
3-2 Mounting the Tool Holders	52
Mounting Tool Holders in the Magazine	52
About the Stocker Numbers	54
3-3 Manual Tool-change	55
Grasping a Tool Holder by Manual Operation	55
Chapter 4 Tool-length Offset	57
4-1 What's the Tool-length Offset?	58
What's the Tool-length Offset?	58
How to Determine the Adjustment Values	58
4-2 Automatic Measurement of Tool Length	59
What's Automatic Measurement of Tool Length?	59
Automatic-measurement Procedure	59
4-3 Entering Adjustment Values Yourself	62
Entering Adjustment Values	62

Fine-tuning the Results of Automatic Measurement of Tool Length	63
4-4 Starting Tool-length Offset	64
When Tool-length Offset Starts	64
Tool-length Offset in a Manual Tool-change	64
Correspondences Between Stocker Numbers and Offset Numbers	64
Chapter 5 Getting Ready for and Performing Cutting	65
5-1 Cutting Area	66
Workpiece Size and Location Where Secured in Place	66
Actual Size That Can Be Cut	67
5-2 Examples of Usage of Tool-length Offset (RML-I Mode)	68
Example of Operations up to Starting Cutting	68
Example of Setting the Z-axis Origin	68
5-3 Examples of Usage of Tool-length Offset (NC-code Mode)	69
Example of Operations up to Starting Cutting	69
Example of Setting the Z-axis Origin	70
Chapter 6 Handy Panel	71
6-1 Features Added to the Handy Panel	72
Features Added to the Handy Panel	72
6-2 Manual Operation of the ATC	73
Basic Operation of the ATC	73
Chapter 7 Appendix	75
7-1 Daily Care	76
Cleaning	76
Bleeding Off Air Pressure	76
Cleaning Inside the Magazine Cover	77
Care and Maintenance of the Tool Holders and Spindle Nose	77
Adjusting the Air Pressure	77
Care and Maintenance of the Air Regulator	78
7-2 Inspection and Maintenance	79
Checking the Total Working Time	79
Lubricating the Spindle	79
When to Replace the Spindle	80
7-3 What to Do If... ..	81
Important Notes on Performing Continuous Cutting for a Prolonged Period	81
The ATC doesn't operate.	81
Tool-change operations fail.	81
The spindle belt is crooked.	81
Responding to an Error Message	81
7-4 NC Code Specifications	83
Items Related to the Mechanical Specifications of the Machine	83
7-5 Unit Specifications	84
Dimensional Drawings	84
Main Specifications	86

Company names and product names are trademarks or registered trademarks of their respective holders.

Copyright© 2006 Roland DG Corporation

<http://www.rolanddg.com/>





To Ensure Safe Use



Improper handling or operation of this machine may result in injury or damage to property. Points which must be observed to prevent such injury or damage are described as follows.

 Please also read the important safety information in the user's manual for the modeling machine.

About WARNING and CAUTION Notices

 WARNING	Used for instructions intended to alert the user to the risk of death or severe injury should the unit be used improperly.
 CAUTION	Used for instructions intended to alert the user to the risk of injury or material damage should the unit be used improperly. * Material damage refers to damage or other adverse effects caused with respect to the home and all its furnishings, as well to domestic animals or pets.

About the Symbols

	The  symbol alerts the user to important instructions or warnings. The specific meaning of the symbol is determined by the design contained within the triangle. The symbol at left means "danger of electrocution."
	The  symbol alerts the user to items that must never be carried out (are forbidden). The specific thing that must not be done is indicated by the design contained within the circle. The symbol at left means the unit must never be disassembled.
	The  symbol alerts the user to things that must be carried out. The specific thing that must be done is indicated by the design contained within the circle. The symbol at left means the power-cord plug must be unplugged from the outlet.

 **Incorrect operation may cause injury**

 **WARNING**

 **Be sure to follow the operation procedures described in this documentation. Never allow anyone unfamiliar with the usage or handling of the machine to touch it.**
Incorrect usage or handling may lead to an accident.

 **Keep children away from the machine.**
The machine includes areas and components that pose a hazard to children and may result in injury, blindness, choking, or other serious accident.

 **Never operate the machine while tired or after ingesting alcohol or any medication.**
Operation requires unimpaired judgment. Impaired judgment may result in an accident.

 **Conduct operations in a clean, brightly lit location.**
Working in a location that is dark or cluttered may lead to an accident, such as becoming caught in the machine as the result of an inadvertent stumble.

 **Before switching on the power, check and ensure the safety of the surrounding area.**
Make sure that movement of the machine poses no danger, including making sure no person is inside the machine's area of operation.

 **Never use the machine for any purpose for which it is not intended, or use the machine in an undue manner that exceeds its capacity.**
Doing so may result in injury or fire.

 **Never use a cutting tool that has become dull. Perform frequent maintenance to keep and use the machine in good working order.**
Unreasonable usage may result in fire or injury.

 **For accessories (optional and consumable items, AC adapter, power cord, and the like), use only genuine articles compatible with this machine.**
Incompatible items may lead to an accident.

 **WARNING**

 **Before attempting cleaning, maintenance, or attachment or detachment of optional items, disconnect the power cord.**
Attempting such operations while the machine is connected to a power source may result in injury or electrical shock.

 **Never attempt to disassemble, repair, or modify the machine.**
Doing so may result in fire, electrical shock, or injury. Entrust repairs to a trained service technician.

 **The cutting waste or workpiece may catch fire or pose a health hazard.**

 **WARNING**

 **Never attempt to cut magnesium or any other such flammable material.**
Fire may occur during cutting.

 **Keep open flame away from the work area.**
Cutting waste may ignite. Powdered material is extremely flammable, and even metal material may catch fire.

 **When using a vacuum cleaner to take up cutting waste, exercise caution to prevent fire or dust explosion.**
Taking up fine cuttings using an ordinary vacuum cleaner may cause danger of fire or explosion. Check with the manufacturer of the vacuum cleaner. When the safety of use cannot be determined, clean using a brush or the like, without using the vacuum cleaner.

 **CAUTION**

 **Wear dust goggles and a mask. Wash away any cutting waste remaining on the hands.**
Accidentally swallowing or inhaling cutting waste may be hazardous to the health.

 **Danger of pinching, entanglement, and burns.**

 **WARNING**

 **Never attempt operation while wearing a necktie, necklace, loose clothing, or gloves. Bind long hair securely.**
Such items may become caught in the machine, resulting in injury.

 **Securely fasten the cutting tool and workpiece in place. After securing in place, make sure no wrenches or other articles have inadvertently been left behind.**
Otherwise such articles may be thrown from the machine with force, posing a risk of injury.

 **Exercise caution to avoid being pinched or becoming caught.**
Inadvertent contact with certain areas may cause the hand or fingers to be pinched or become caught. Use care when performing operations.

 **WARNING**

 **Caution: cutting tool.**
The cutting tool is sharp. To avoid injury, exercise caution.

 **Caution: high temperatures.**
The cutting tool and spindle motor become hot. Exercise caution to avoid fire or burns.

 **Danger of electrical short, shock, electrocution, or fire**

 **WARNING**

 **Never use out of doors or in any location where exposure to water or high humidity may occur. Never touch with wet hands.**
Doing so may result in fire or electrical shock.

 **Never allow any foreign object to get inside. Never expose to liquid spills.**
Inserting objects such as coins or matches or allowing beverages to be spilled into the ventilation ports may result in fire or electrical shock. If anything gets inside, immediately disconnect the power cord and contact your authorized Roland DG Corp. dealer.

 **Never place any flammable object nearby. Never use a combustible aerosol spray nearby. Never use in any location where gases can accumulate.**
Combustion or explosion may be a danger.

 **WARNING**

 **Never use cutting oil.**
This machine is not designed for the flow of cutting oil. Oil may get inside the machine and cause fire or electrical shock.

 **Never use a pneumatic blower.**
This machine is not compatible with a pneumatic blower. Cutting waste may get inside the machine and cause fire or electrical shock.

 **If sparking, smoke, burning odor, unusual sound, or abnormal operation occurs, immediately unplug the power cord. Never use if any component is damaged.**
Continuing to use the machine may result in fire, electrical shock, or injury. Contact your authorized Roland DG Corp. dealer.

 **Danger exists of components being thrown off or damaged.**

 **WARNING**

 **Connect the air hose securely, so that it will not come loose.**
A pressurized hose that comes loose may whip about uncontrolled, posing a hazard. Connect securely.

 **Before attempting cleaning, maintenance, or attachment or detachment of the air hose or any optional items, stop the supply of compressed air and allow the pressure to escape.**
Allowing the equipment to remain under pressure poses a hazard of flying components.

 **When the machine will be out of use for a prolonged period, stop supply of compressed air and bleed off the air pressure.**
This can prevent an accident.

 **Use an air hose of the specified diameter and having adequate pressure resistance.**
Otherwise the article may come loose or rupture.

 **Keep the supply of compressed air within the specified pressure range.**
Exceeding the specified pressure may result in rupture or other major accident.

 **Ensure no contamination of the supplied compressed air by any water, oils, chemicals, or foreign objects.**
Components may deteriorate or rupture, or the contaminants may be scattered, posing a hazard.

 **Never use in a location exposed to cutting oil, solvents, chemicals, or other such substances.**
Components may deteriorate or rupture under the pressure of compressed air.

 **Never use in a location exposed to direct sunlight.**
Components may deteriorate or rupture under the pressure of compressed air.

 **WARNING**

 **Never strike or subject the object to impact.**
Components may suffer damage or rupture under the pressure of compressed air.

 **Keep the temperature of the installation area within the specified range. Never place a stove or heater nearby.**
Components may deteriorate or rupture under the pressure of compressed air.

 **Never damage the air hose, or bend or twist it with undue force. Never use an item that has deteriorated.**
A damaged air hose may rupture.

 **Important notes about the end (cut edge) of the air hose**

Failure to observe these cautions may result in air leakage or easy dislodgement of the air hose. Also, when a hose has been detached, cut off the end before reattaching the hose.

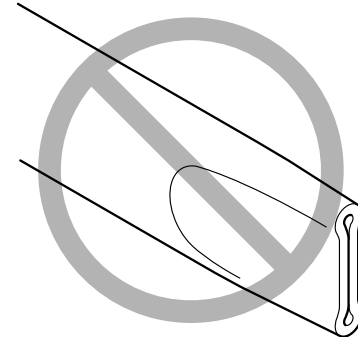
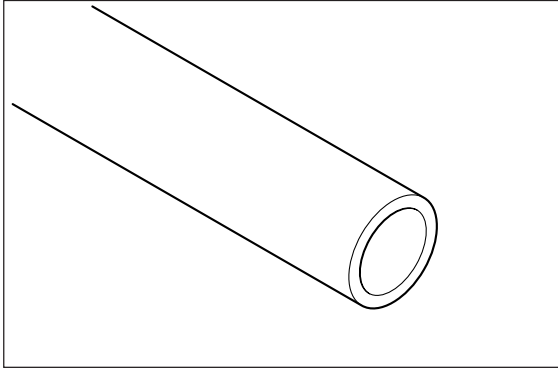

Ensure that it is not crushed.

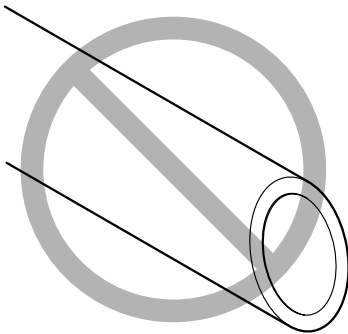

Make the cut edge straight.

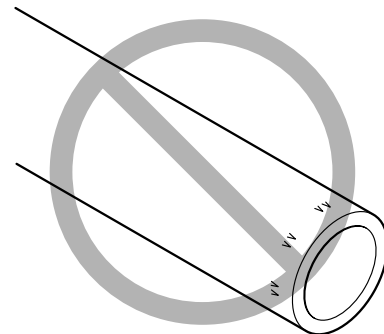

Keep free from damage or soiling.

⚠ Warning Labels

Warning labels are affixed to make areas of danger immediately clear. The meanings of these labels are as follows. Be sure to heed their warnings.

Also, never remove the labels or allow them to become obscured.

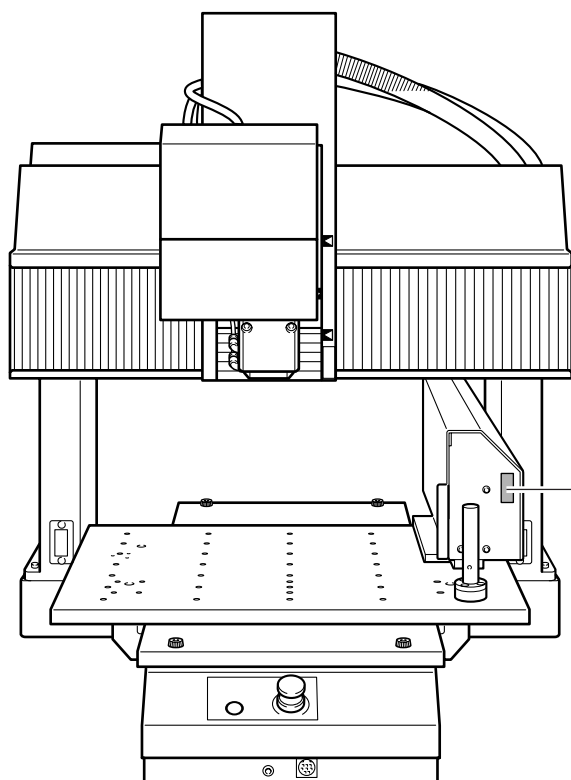

Caution: Pinching Hazard
Contact during operation may cause the hand or fingers to become pinched, resulting in injury.





Pour utiliser en toute sécurité

La manipulation ou l'utilisation inadéquates de cet appareil peuvent causer des blessures ou des dommages matériels. Les précautions à prendre pour prévenir les blessures ou les dommages sont décrites ci-dessous.









Lire sans faute les importants renseignements sur la sécurité dans le guide de l'utilisateur de la machine à modeler.

Avis sur les avertissements

 ATTENTION	Utilisé pour avertir l'utilisateur d'un risque de décès ou de blessure grave en cas de mauvaise utilisation de l'appareil.
 PRUDENCE	Utilisé pour avertir l'utilisateur d'un risque de blessure ou de dommage matériel en cas de mauvaise utilisation de l'appareil. * Par dommage matériel, il est entendu dommage ou tout autre effet indésirable sur la maison, tous les meubles et même les animaux domestiques.

À propos des symboles

	Le symbole  attire l'attention de l'utilisateur sur les instructions importantes ou les avertissements. Le sens précis du symbole est déterminé par le dessin à l'intérieur du triangle. Le symbole à gauche signifie "danger d'électrocution".
	Le symbole  avertit l'utilisateur de ce qu'il ne doit pas faire, ce qui est interdit. La chose spécifique à ne pas faire est indiquée par le dessin à l'intérieur du cercle. Le symbole à gauche signifie que l'appareil ne doit jamais être démonté.
	Le symbole  prévient l'utilisateur sur ce qu'il doit faire. La chose spécifique à faire est indiquée par le dessin à l'intérieur du cercle. Le symbole à gauche signifie que le fil électrique doit être débranché de la prise.

 **L'utilisation incorrecte peut causer des blessures**

 **ATTENTION**

 **S'assurer de suivre les procédures d'utilisation décrites dans la documentation. Ne jamais permettre à quiconque ne connaît pas le fonctionnement ou la manutention de l'appareil de le toucher.**
L'utilisation ou la manutention incorrectes peuvent causer un accident.

 **Garder les enfants loin de l'appareil.**
L'appareil comporte des zones et des composants qui présentent un danger pour les enfants et qui pourraient causer des blessures, la cécité, la suffocation ou d'autres accidents graves.

 **Ne jamais faire fonctionner l'appareil après avoir consommé de l'alcool ou des médicaments, ou dans un état de fatigue.**
L'utilisation de l'appareil exige un jugement sans faille. L'utilisation avec les facultés affaiblies pourrait entraîner un accident.

 **Utiliser l'appareil dans un endroit propre et bien éclairé.**
Travailler dans un endroit sombre ou encombré peut causer un accident; l'utilisateur risque, par exemple, de trébucher malencontreusement et d'être coincé par une partie de l'appareil.

 **Avant de mettre l'appareil sous tension, vérifier et s'assurer que les environs sont sécuritaires.**
S'assurer que les mouvements de l'appareil ne présentent aucun danger; s'assurer en particulier que personne ne se trouve dans la zone de fonctionnement de l'appareil.

 **Ne jamais utiliser l'appareil à des fins autres que celles pour lesquelles il est conçu. Ne jamais l'utiliser de manière abusive ou d'une manière qui dépasse sa capacité.**
Le non-respect de cette consigne peut causer des blessures ou un incendie.

 **Ne jamais utiliser un outil de coupe émoussé. Procéder fréquemment aux travaux d'entretien pour garder l'appareil en bon état de fonctionnement.**
L'usage abusif peut causer un incendie ou des blessures.

 **ATTENTION**

 **Utiliser uniquement des accessoires d'origine (accessoires en option, articles consommables, adaptateur CA, câble d'alimentation et autres articles semblables), compatibles avec l'appareil.**
Les articles incompatibles risquent de causer des accidents.

 **Débrancher le câble d'alimentation avant de procéder au nettoyage ou à l'entretien de l'appareil, et avant d'y fixer ou d'en retirer des accessoires en option.**
Tenter ces opérations pendant que l'appareil est branché à une source d'alimentation peut causer des blessures ou un choc électrique.

 **Ne jamais tenter de démonter, de réparer ou de modifier l'appareil.**
Le non-respect de cette consigne risque de provoquer un incendie, un choc électrique ou des blessures. Confier les réparations à un technicien ayant la formation requise.

 **Les débris de coupe peuvent s'enflammer ou présenter un risque pour la santé.**

 **ATTENTION**



Ne jamais tenter de couper du magnésium ni aucun autre matériau inflammable.

Un incendie pourrait se produire pendant la coupe.



Ne pas approcher une flamme nue de l'espace de travail.

Les rognures de coupe peuvent s'enflammer. Les matériaux pulvérisés sont extrêmement inflammables et même le métal peut s'enflammer.



Si un aspirateur est utilisé pour ramasser les rognures de coupe, faire preuve de prudence pour empêcher que la poussière s'enflamme ou explose.

Ramasser des rognures fines à l'aide d'un aspirateur ordinaire peut créer un risque d'incendie ou d'explosion. Vérifier auprès du fabricant de l'aspirateur. Dans les cas où il est impossible de déterminer si un aspirateur peut être utilisé sans danger, se servir d'une brosse ou d'un article semblable plutôt que d'un aspirateur.

 **PRUDENCE**



Porter des lunettes de protection et un masque. Rincer toutes les rognures de coupe qui pourraient rester collées aux mains.

Avaler ou respirer accidentellement des rognures de coupe peut être dangereux pour la santé.

 **Certains éléments peuvent présenter un risque de pincement, d'emmêlement, de brûlure ou d'autres dangers.**

 **ATTENTION**

 **Ne jamais faire fonctionner l'appareil si on porte une cravate, un collier, des vêtements amples ou des gants. Bien attacher les cheveux longs.**

Ces vêtements ou ces objets peuvent être coincés dans l'appareil, ce qui causerait des blessures.

 **Fixer solidement l'outil de coupe et la pièce à travailler. Une fois qu'ils sont fixés solidement, s'assurer qu'aucun outil ni aucun autre objet n'a été laissé en place.**

Si tel était le cas, ces objets pourraient être projetés avec force hors de l'appareil et causer des blessures.

 **Faire preuve de prudence pour éviter l'écrasement ou le coincement.**

La main ou les doigts peuvent être écrasés ou coincés s'ils entrent en contact avec certaines surfaces par inadvertance. Faire preuve de prudence pendant l'utilisation de l'appareil.

 **ATTENTION**

 **Attention : outil de coupe.**
L'outil de coupe est acéré. Faire preuve de prudence pour éviter les blessures.

 **Attention : températures élevées.**
L'outil de coupe et le moteur chauffent. Faire preuve de prudence pour éviter un incendie ou des brûlures.

 **Risque de décharge ou de choc électrique, d'électrocution ou d'incendie**

 **ATTENTION**



Ne jamais utiliser à l'extérieur ni à un endroit où l'appareil risque d'être exposé à de l'eau ou à une humidité élevée. Ne jamais toucher l'appareil avec des mains mouillées.

Le non-respect de cette consigne risque de provoquer un incendie ou un choc électrique.



Ne jamais insérer d'objet étranger dans l'appareil. Ne jamais exposer l'appareil aux déversements de liquides.

L'insertion d'objets comme des pièces de monnaie ou des allumettes, ou le déversement de liquides dans les orifices de ventilation peuvent causer un incendie ou un choc électrique. Si un objet ou du liquide s'infiltré dans l'appareil, débrancher immédiatement le câble d'alimentation et communiquer avec le représentant Roland DG Corp. autorisé.



Ne jamais placer d'objet inflammable à proximité de l'appareil. Ne jamais utiliser de produit inflammable en aérosol à proximité de l'appareil. Ne jamais utiliser l'appareil dans un endroit où des gaz peuvent s'accumuler.

Une combustion ou une explosion pourraient se produire.

 **ATTENTION**



Ne jamais utiliser d'huile de coupe.

Cet appareil n'est pas conçu pour traiter l'huile de coupe. L'huile peut s'infiltrer à l'intérieur et causer un incendie ou un choc électrique.



Ne jamais utiliser d'air sous pression.

Cet appareil n'est pas conçu pour être nettoyé à l'aide d'un appareil soufflant. Des rognures de coupe peuvent s'infiltrer à l'intérieur et causer un incendie ou un choc électrique.





S'il se produit des étincelles, de la fumée, une odeur de brûlé, un bruit inhabituel ou un fonctionnement anormal, débrancher immédiatement le câble d'alimentation. Ne jamais utiliser si un composant est endommagé.

Continuer à utiliser l'appareil peut causer un incendie, un choc électrique ou des blessures. Communiquer avec le représentant Roland DG Corp. Autorisé.

 **Il y a risque que des composants soient projetés ou endommagés.**

 **ATTENTION**

 **Connecter solidement le tuyau à air pour éviter qu'il se détache.**
Un tuyau sous pression qui se détache peut fouetter l'air de manière désordonnée et créer une situation dangereuse. Le fixer solidement.

 **Avant de procéder au nettoyage ou à la maintenance de l'appareil, d'y fixer ou d'en détacher le tuyau à air ou un accessoire en option, arrêter l'alimentation en air comprimé et laisser la pression s'échapper.**
Si l'équipement est laissé sous pression, il y a risque que des éléments soient projetés.

 **Si l'appareil doit rester inutilisé pendant une longue période, couper l'alimentation en air comprimé et purger la pression.**
Cette précaution peut prévenir un accident.

 **Utiliser un tuyau à air du diamètre spécifié et ayant une résistance appropriée à la pression.**
Sinon, le tuyau risque de se détacher ou de se rompre.

 **Garder l'alimentation en air comprimé à la pression spécifiée.**
Appliquer une pression supérieure à la pression spécifiée risque de faire rompre le tuyau ou de causer un accident grave.

 **S'assurer que l'air comprimé n'est pas contaminé par de l'eau, de l'huile, des produits chimiques ou des objets étrangers.**
Les composants pourraient se détériorer ou se rompre et les contaminants seraient projetés, ce qui créerait un danger.

 **Ne jamais utiliser dans un endroit exposé à de l'huile de coupe, à des solvants, à des produits chimiques ou à d'autres substances similaires.**
Les composants pourraient se détériorer ou se rompre sous la pression de l'air comprimé.

 **Ne jamais utiliser dans un endroit exposé directement aux rayons du soleil.**
Les composants pourraient se détériorer ou se rompre sous la pression de l'air comprimé.

 **ATTENTION**

 **Ne jamais frapper ni soumettre l'objet à un impact.**
Les composants pourraient être endommagés ou se rompre sous la pression de l'air comprimé.

 **Garder la température de l'endroit où l'appareil est installé dans les limites spécifiées. Ne jamais placer un four ou un appareil de chauffage à proximité.**
Les composants pourraient se détériorer ou se rompre sous la pression de l'air comprimé.

 **Ne jamais endommager le tuyau à air, le plier ou le tordre avec une force excessive. Ne jamais utiliser un article détérioré.**
Un tuyau à air endommagé risque de se rompre.

 Remarques importantes relativement à l'extrémité (bord coupé) du tuyau à air.

Le non-respect de ces consignes de sécurité peut causer une fuite d'air ou le débranchement du tuyau à air. En outre, si le tuyau à air a été débranché, en couper l'extrémité avant de le rebrancher.

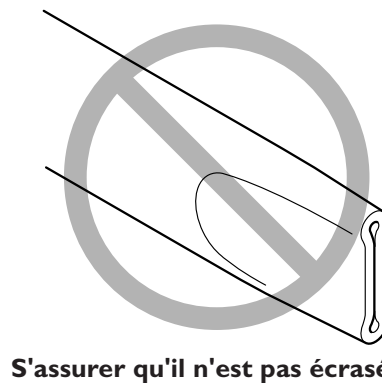
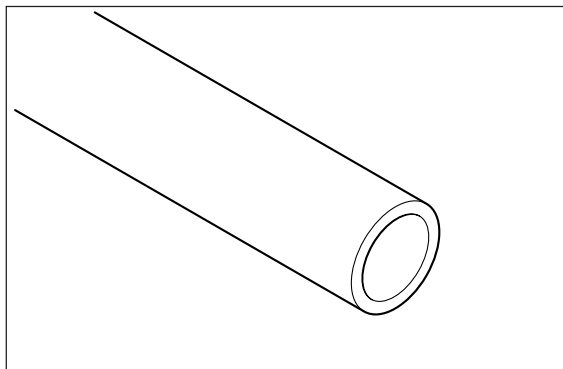

S'assurer qu'il n'est pas écrasé

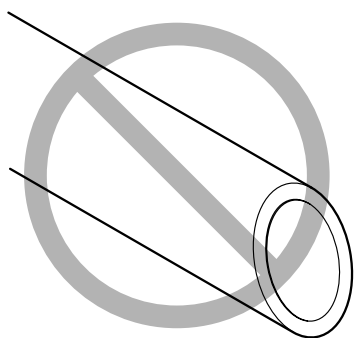

Le bord coupé doit être droit

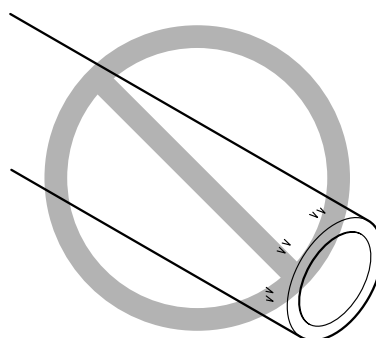

Le garder en bon état et propre

⚠ Vignettes d'avertissement

Des vignettes d'avertissement sont apposées pour qu'il soit facile de repérer les zones dangereuses. La signification des vignettes est donnée ci-dessous. Respecter les avertissements. Ne jamais retirer les vignettes et ne pas les laisser s'encrasser.

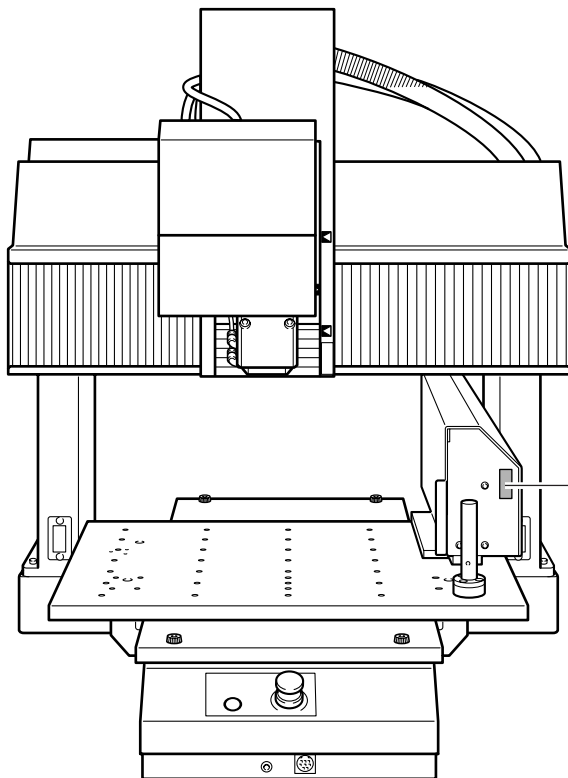

Attention : risque de pincement

Un contact pendant le fonctionnement peut coincer la main ou les doigts ce qui risque de causer des blessures.

Important Notes on Handling and Use

This machine is a precision device. To ensure the full performance of this machine, be sure to observe the following important points. Failure to observe these may not only result in loss of performance, but may also cause malfunction or breakdown.

ATC Unit

This machine is a precision device.

- Handle carefully, and never subject the machine to impact or excessive force.
- Use within the range of specifications.
- Diligently keep clean of cutting waste.
- Never attempt to move the magazine cover by hand with undue force.

Install in a suitable location.

- Install in a location that meets the specified conditions for temperature, relative humidity, and the like.
- Install in a quiet, stable location offering good operating conditions.

This machine becomes hot.

- Never cover the ventilation holes with cloth, tape, or anything else.

Chapter 1

Introduction

I-I Introduction

Features

- This is an optional unit for adding an automatic tool changer (ATC) to the MODELA Pro II from Roland DG Corp.
- The bolt-on design allows easy installation.
- The tool-length offset feature and automatic tool-length measurement feature also make it easy to selectively use tools of different lengths.
- Use in combination with a rotary axis unit is possible.

Installable Model

Supported Model

MODELA Pro II MDX-540

- Installation on a machine equipped with either the standard table or the T-slot table is possible.
- Use in combination with a rotary axis unit is possible.
- A compressor or other source of compressed air must be provided separately.
- An air hose for connecting the compressed-air source to the unit must be provided separately.
- The tool holders are not included. They must be provided separately.

Organization of the Documentation

Installation and operation this unit require prior knowledge of the handling and operation of the modeling machine. Before you read this document, be sure to familiarize yourself with the handling and operation of the modeling machine.

This document describes the following.

- How to install the unit
- How to adjust and perform maintenance for the unit
- Explanations of features added by the unit

For matters not described by this document, refer to the documentation included with the modeling machine.

User's Manual for the MDX-540A (ATC-equipped Model)

Read the "MDX-540 User's Manual" together with this manual. This manual describes only matters related to the ATC unit. Basic matters related to the modeling machine are described in the "MDX-540 User's Manual."

I-2 Names and Functions

External View

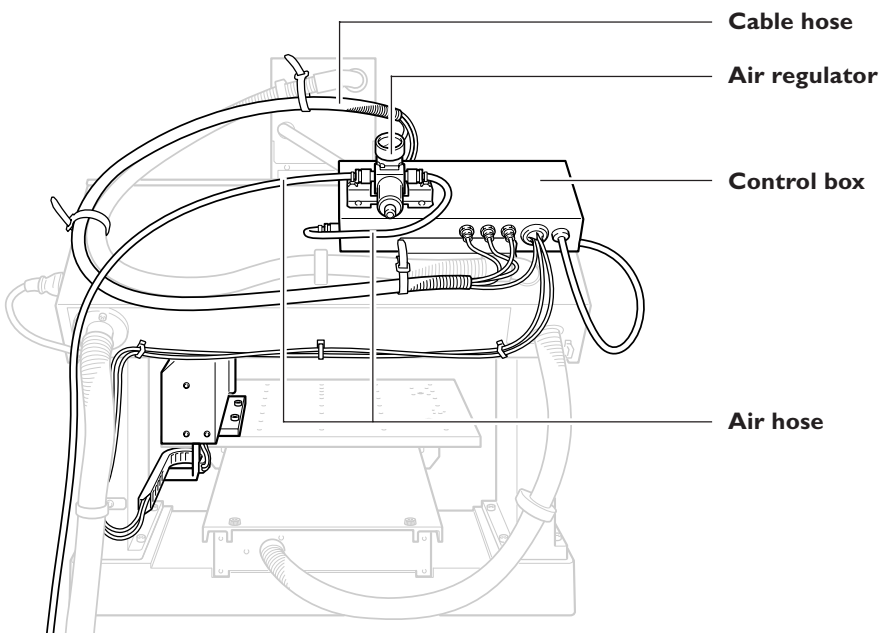
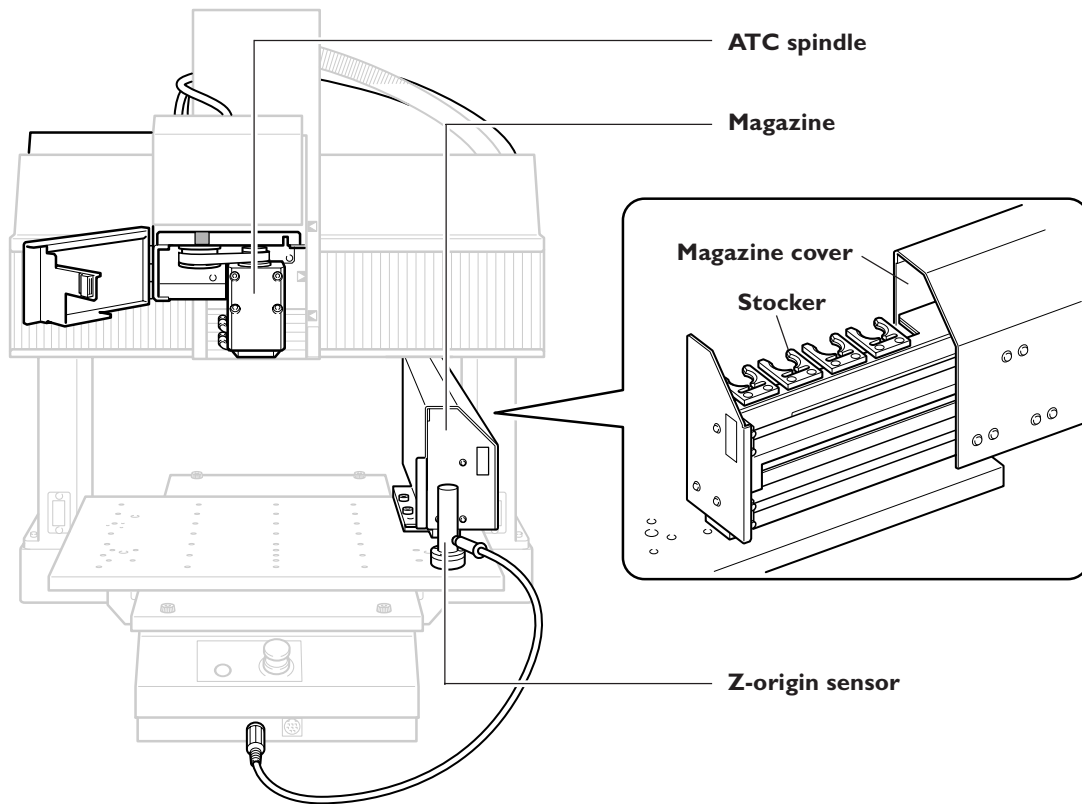

VPanel

Installing the ATC unit enables you to perform operations for items that involve the ATC unit.

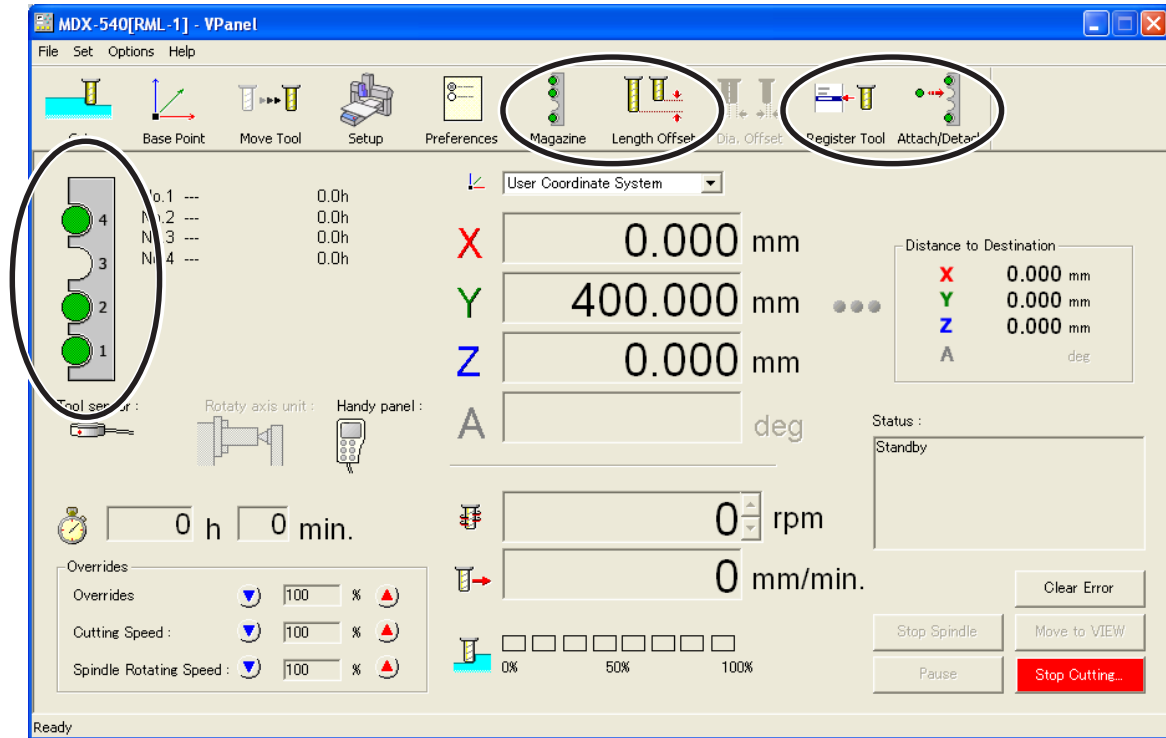









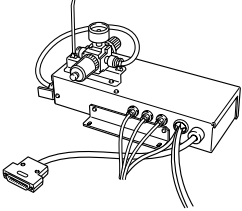
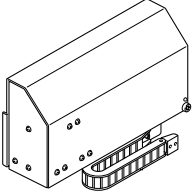
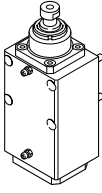
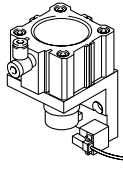
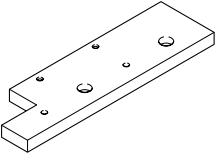
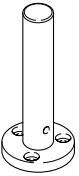

Chapter 2

Installation

2-1 Before Installing

Checking the Included Items

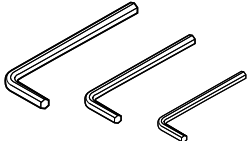
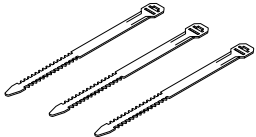
The following items are included with the unit. Make sure they are all present and accounted for.

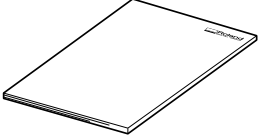
 Control box ^{(#1)(#2)}	 Magazine unit ^(#1)	 ATC spindle	 Air cylinder
 Base plate ^(#3)	 Z-origin sensor ^(#5)	 Spacer ^{(#3)(#5)}	 Stripper bolts (d8 x L15 mm) x2
 Cap screws (M8 x 20 mm) x2 ^(#3)	 Cap screws (M8 x 16 mm) x4	 Cap screws (M4 x 30 mm) x3 ^{(#3)(#5)}	 Cap screws (M4 x 15 mm) x3 ^{(#4)(#5)}
 Cap screws (M4 x 8 mm) x2	 Hexagonal wrenches (6 mm, 5 mm, 3 mm)	 Retaining bands (large) x3	 Cable retainers x3
 User's Manual (this manual)	<p>*1 The magazine unit and control box are connected by cabling. The cabling cannot be detached.</p> <p>*2 The pressure gauge for the air regulator does not face directly upward, but this is intentional and not a defect.</p> <p>*3 Not used on machines installed with a T-slot table.</p> <p>*4 Not used on machines installed with the standard table.</p> <p>*5 Not used in the case of usage in combination with a rotary axis unit (ZCL-540).</p>		

Items Included with the MDX-540A (ATC-equipped Model)

- > On the MDX-540A, the following items are already installed on the machine: Control box, magazine unit, ATC spindle, air cylinder, base plate, cap screws (M8 x 20 mm, M8 x 16 mm, and M4 x 8 mm), stripper bolts, retaining bands, and cable retainers.
- > The following item is not included with the MDX-540A: Hexagonal wrench (6 mm).
- > For information on other items included with the MDX-540A, refer to the "MDX-540 User's Manual."

Preparing the Compressed-air Source

- ⚠ WARNING** The pressure of the compressed air must be not more than 1 MPa. Exceeding this may cause rupture or other serious accident.
- ⚠ WARNING** Ensure no contamination of the supplied compressed air by any water, oils, chemicals, or foreign objects. Components may deteriorate or rupture, or the contaminants may be scattered, posing a hazard.

This unit requires compressed air. Provide a compressor or other source that meets the following conditions.

- Air pressure: 0.7 to 1.0 MPa
- Amount of air: 50 L/min
- Contamination by moisture, oils, chemicals, or other foreign matter is not permitted. The air must be dry.

Attach the piping from the unit as described below. Use a suitable air hose.

- Hose outer diameter: 10 mm (polyurethane tube)

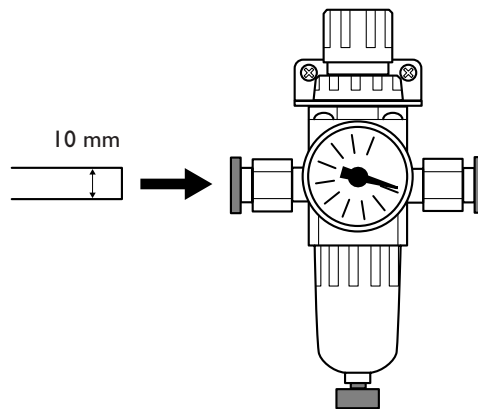

About the Compressor

- Contamination of the compressed air by foreign matter is undesirable. Use an oil-free compressor.
- Moist air may cause rust. Use a device equipped with a dryer.
- Stable pressure is required. Select a source that has an adequate tank capacity.
- Be sure to drain periodically.

Preparing the Tool Holders

Provide tool holders that meet the following conditions.

Dimensions

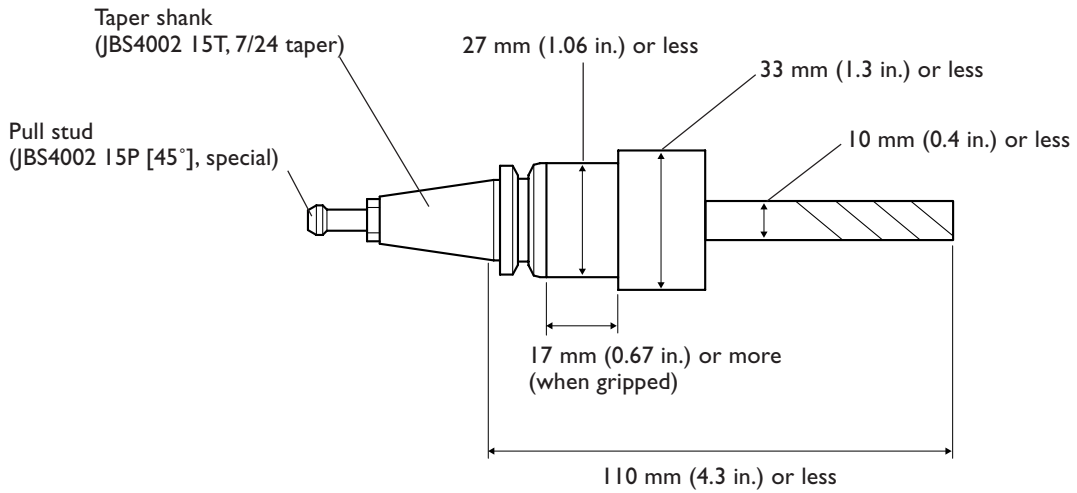

Weight

Ensure that the weight, including the end mill and the like, is not more than 350 g (0.77 lb.).

Taper-shank portion

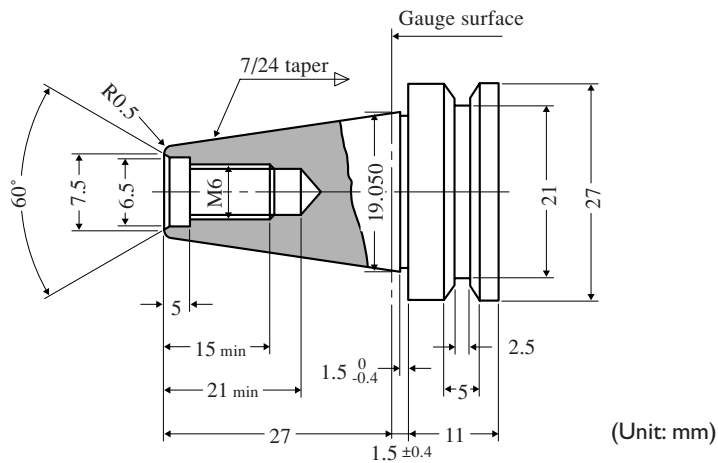

Pull-stud portion

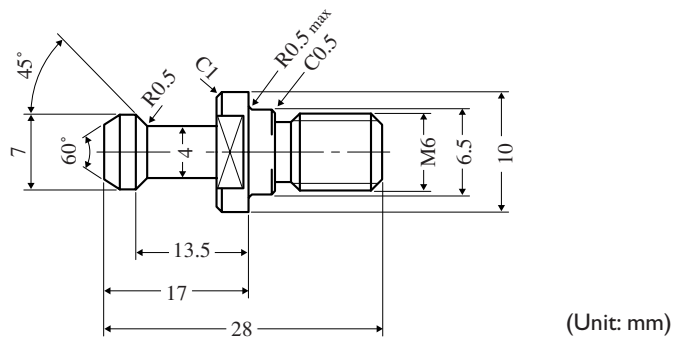

Overview of the Installation Procedure

This is an overview of the installation procedure. For the specific steps required to install this unit, see the following section.

Set Up the Modeling machine

- Finish installing the modeling machine, installing and setting up the program and other software, and connecting the modeling machine to the computer.
- If an optionally available T-slot table is to be used, finish installing it at this time.
- If an optionally available safety cover is to be used, leave it uninstalled at this time.



Install the ATC Unit

Install this unit.



Install the Rotary Axis Unit

When you are using the unit in combination with a rotary axis unit, install the ATC unit first, before you install the rotary axis unit.

Important Notes on Installation Operations

- before installing, clean away any cutting waste and any soiling on the installation surface. Any foreign matter that becomes caught between components may reduce accuracy.
- For several parts, the installation location is determined by butting the part flush against a surface. Because accuracy can be reduced by improper contact when doing this, carry out such procedures especially carefully.

About Use in Combination with a Rotary Axis Unit

If you intend to use this unit in combination with a rotary axis unit, then install this unit first, before you install the rotary axis unit. If the rotary axis unit is already installed on the machine, then it must first be removed.

About Installation of a Safety Cover

If you're using an optionally available safety cover, install this unit first, and then install the safety cover. If the safety cover is already installed, then remove it.

About VPanel Settings

VPanel automatically detects this unit when it is installed. You don't need to make any special settings.

Required Setup Operations for the MDX-540A (ATC-equipped Model)

For the MDX-540A, carry out the following operations.

- In "2-3 Step 2: Attach the Magazine Unit," the procedures for mounting the Z-origin sensor (p. 35 or p. 38)
- The procedures in "2-6 Step 5: Supply Compressed Air" (p. 45)

Other installation and mounting operations are complete at the time the machine is shipped from the factory.

2-2 Step 1: Attach the Control Box

Attach the Control Box

Procedure

1

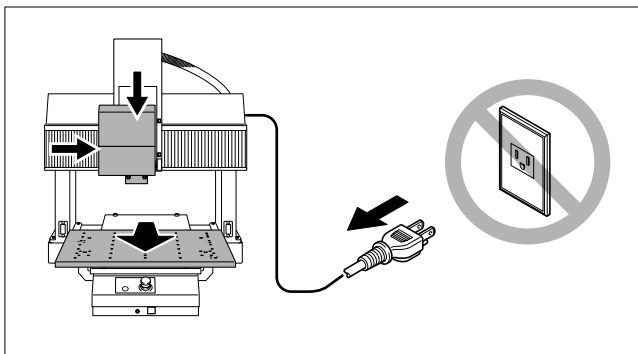

Prepare the modeling machine.

- 1 Perform manual feed to move the table to the front.
- 2 Use manual feed to move the spindle head to a position about halfway along the X axis and at the lowest location on the Z axis.
- 3 Shut down the modeling machine and disconnect the power cable.

⚠ WARNING: Be sure to disconnect the power cable. Failure to do so may result in danger of injury.

2

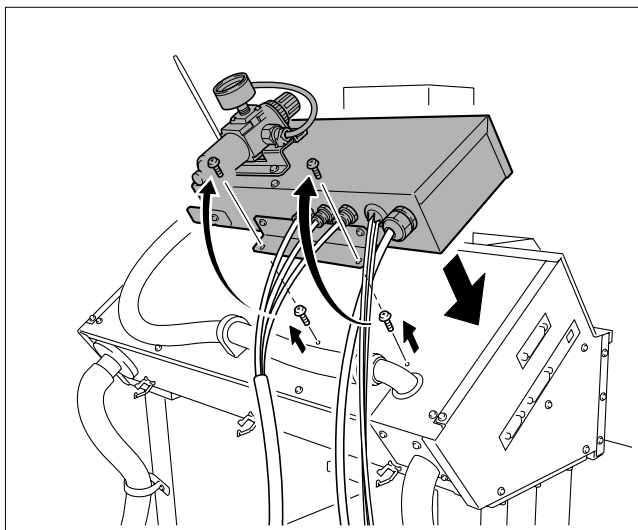

- 1 Remove the two screws.
- 2 Use the screws to attach the control box.

Continue by proceeding with "2-3 Step 2: Attach the Magazine Unit."

2-3 Step 2: Attach the Magazine Unit

For a Standard Table

The installation method differs slightly depending on the type of table. If the original standard table is attached, then follow the procedure below to install.

Procedure

1

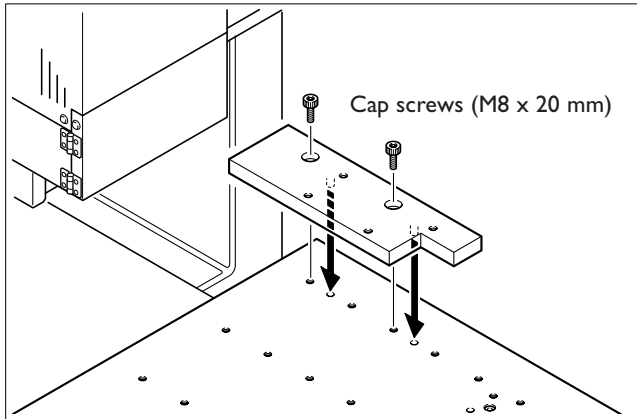

Install the base plate.

2

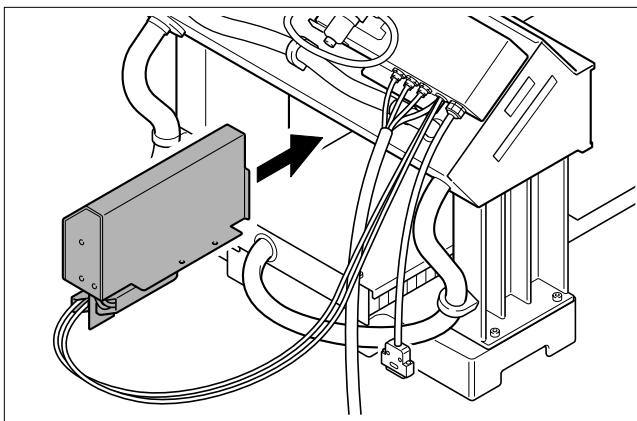

From the rear of the modeling machine, pull in the magazine unit.

3

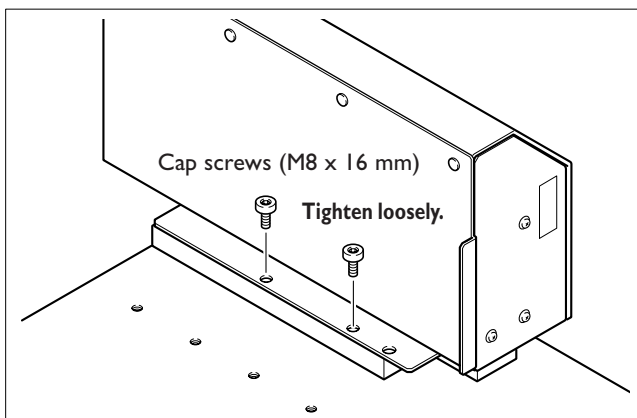

Loosely tighten the magazine unit in place.

2-3 Step 2: Attach the Magazine Unit

- 4 ① Fit the tabs on the underside of the magazine unit into the base plate.
② Tighten the cap screws.

Correct tool-change is impossible if the tabs are not engaged properly. Perform positioning carefully.

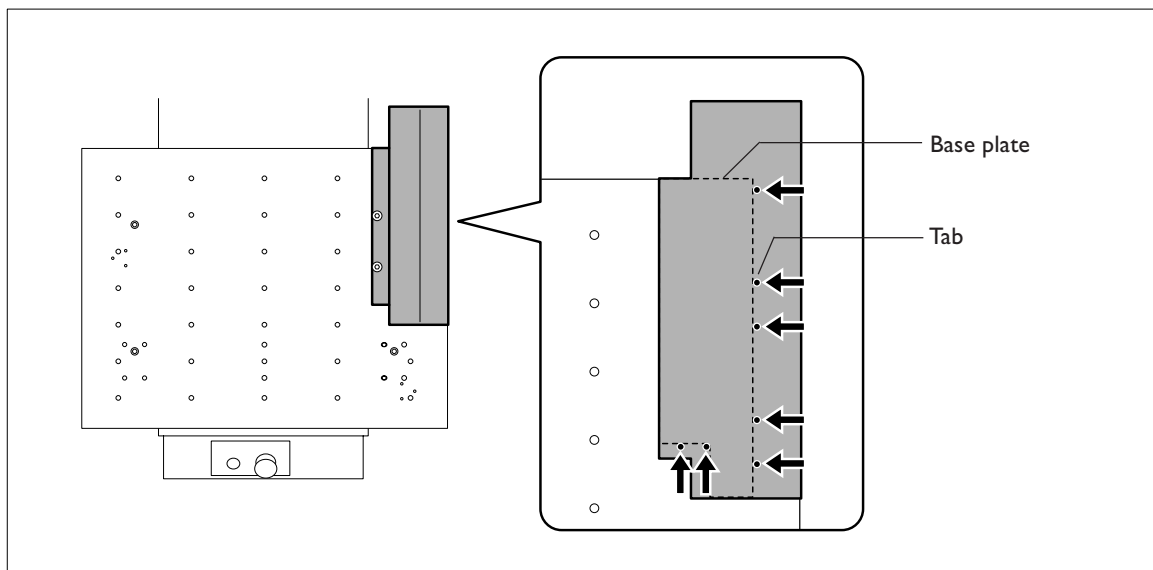

5

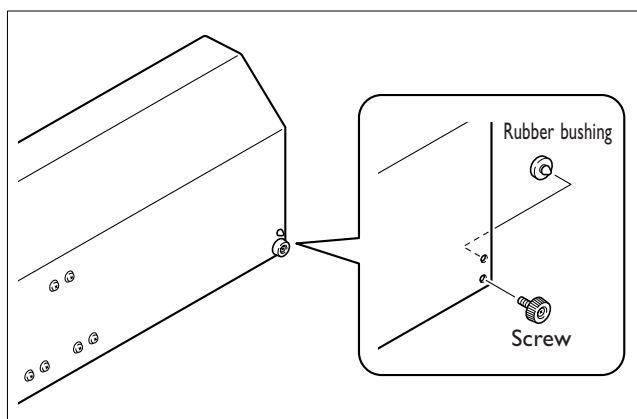

- ① Remove the screw.
② Gently open the magazine cover and remove the rubber bushing.

6

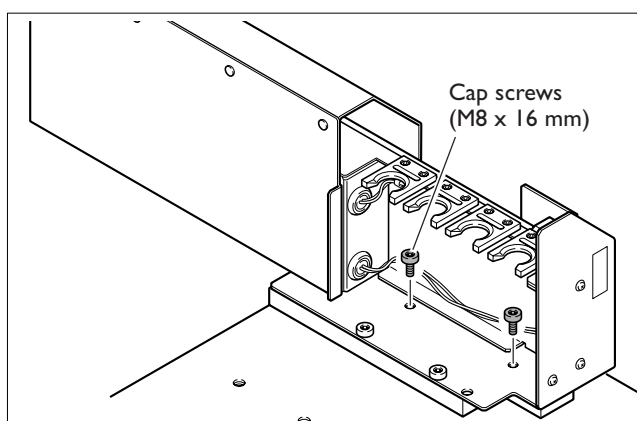

- ① Secure in place with two more cap screws.
② Gently close the magazine cover.

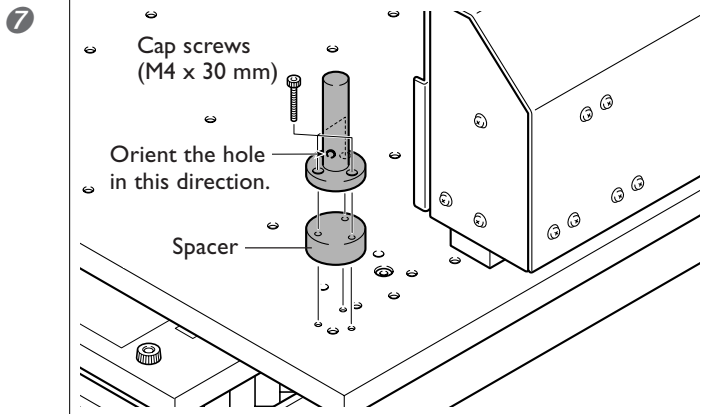

No Rotary Axis Unit
Install the Z-origin sensor.

For Use in Combination with a Rotary Axis Unit
Installation of the Z-origin sensor is not required.

8 Secure the cable carrier in place.

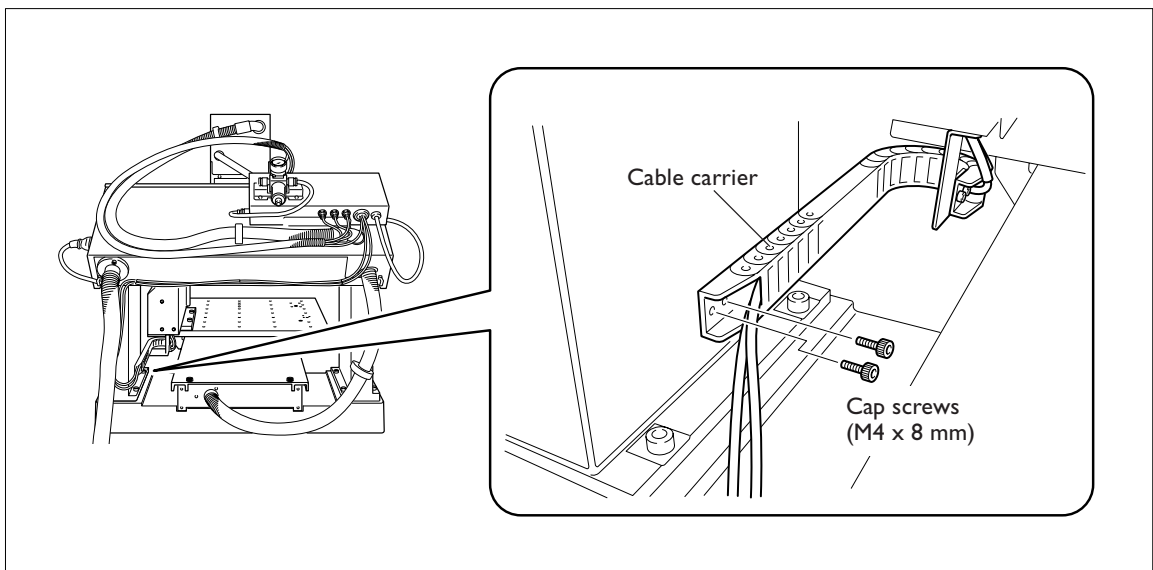

Continue by proceeding with "2-4 Step 3: Attach the Spindle and Cylinder."

For a T-slot Table

The installation method differs slightly depending on the type of table. If an optionally available T-slot table is attached, then follow the procedure below to install.

Procedure

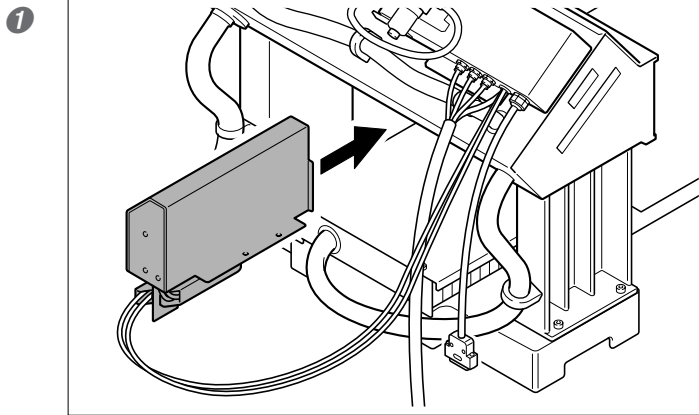

From the rear of the modeling machine, pull in the magazine unit.

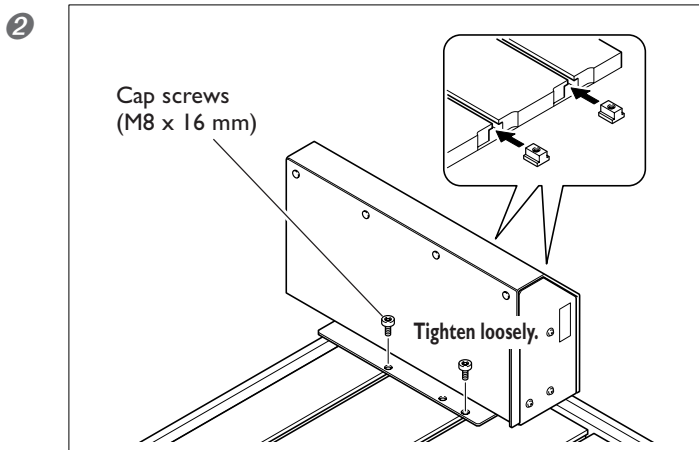

- ① Slide the T-slot nuts into the grooves.
- ② Loosely tighten the magazine unit in place.

The T-slot nuts are included with the T-slot table.

- 3 ① Fit the tabs on the underside of the magazine unit into locations shown in the figure.
 ② Tighten the cap screws.

Correct tool-change is impossible if the tabs are not engaged properly. Perform positioning carefully.

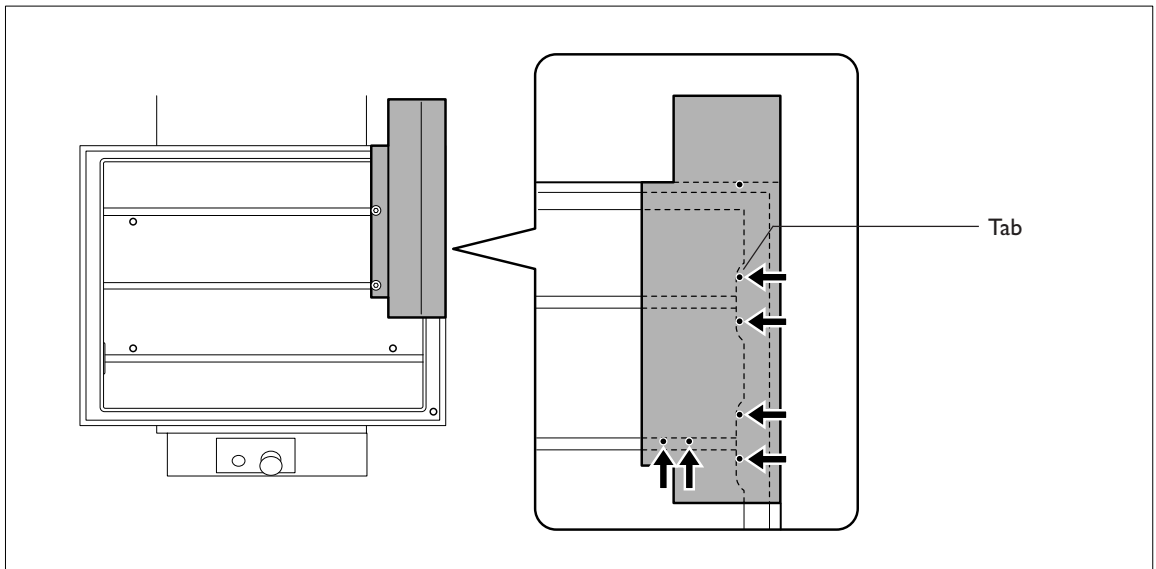

4

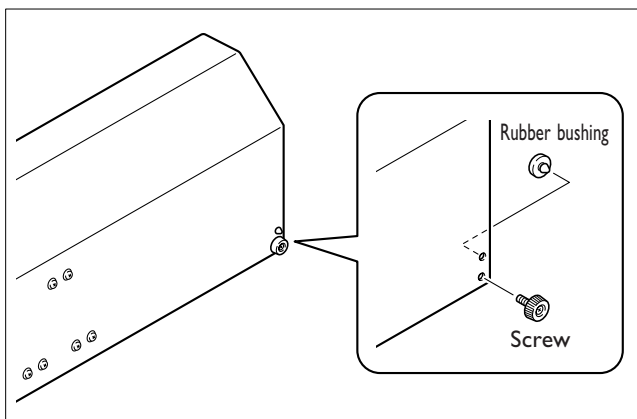

- ① Remove the screws.
 ② Gently open the magazine cover and remove the rubber bushing.

5

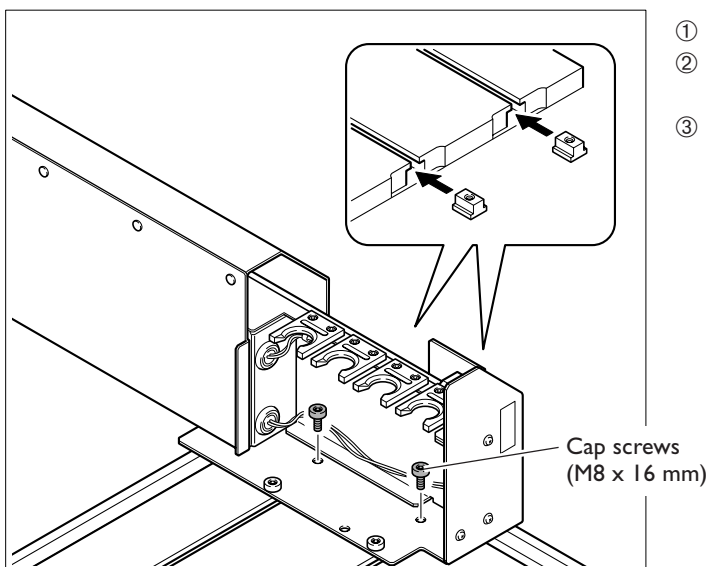

- ① Slide the T-slot nuts into the grooves.
 ② Secure in place with two more cap screws.
 ③ Gently close the magazine cover.

2-3 Step 2: Attach the Magazine Unit

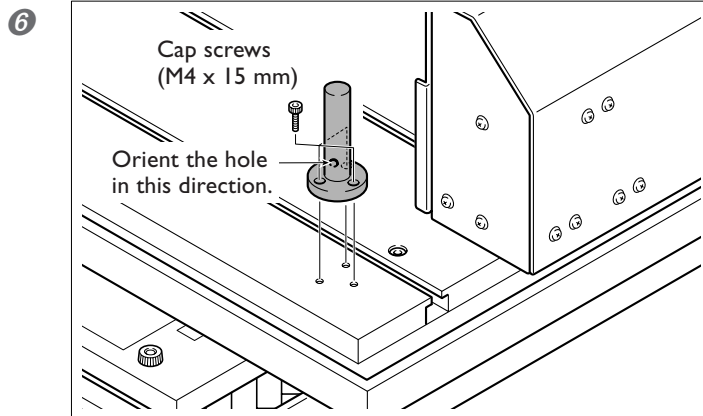

No Rotary Axis Unit
Install the Z-origin sensor.

For Use in Combination with a Rotary Axis Unit
Installation of the Z-origin sensor is not required.

7 Secure the cable carrier in place.

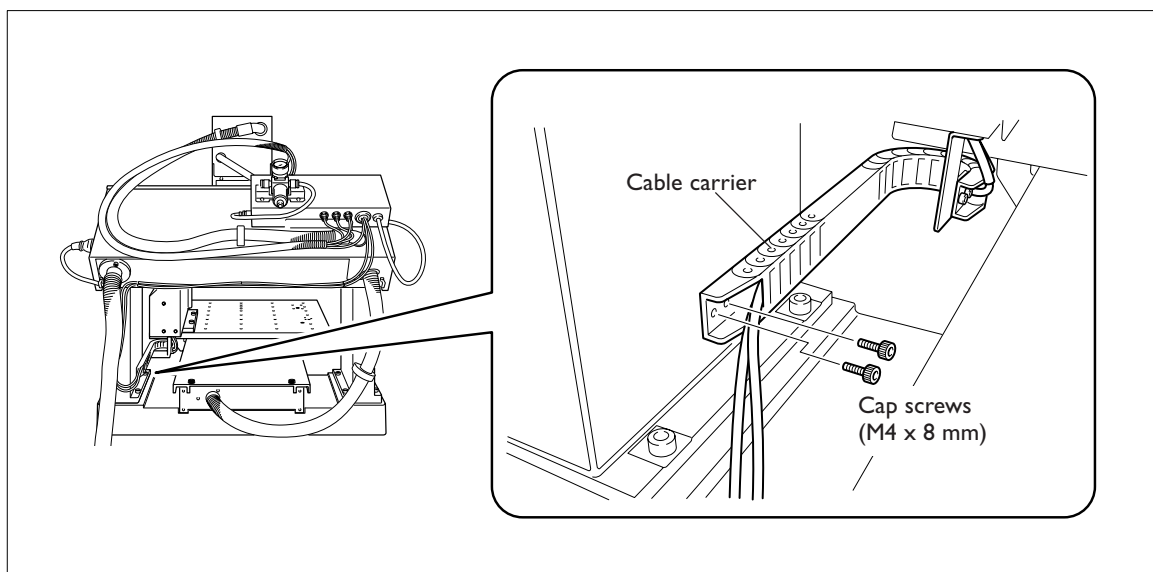

Continue by proceeding with "2-4 Step 3: Attach the Spindle and Cylinder."

2-4 Step 3: Attach the Spindle and Cylinder

Attach the Spindle and Cylinder

Procedure

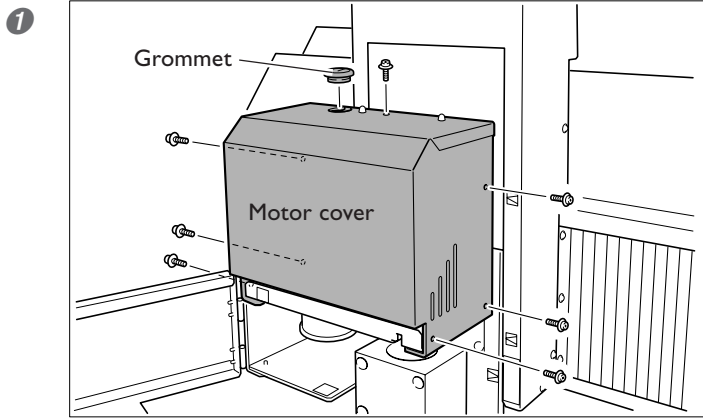

- ① Detach the motor cover.
- ② Remove the grommet.

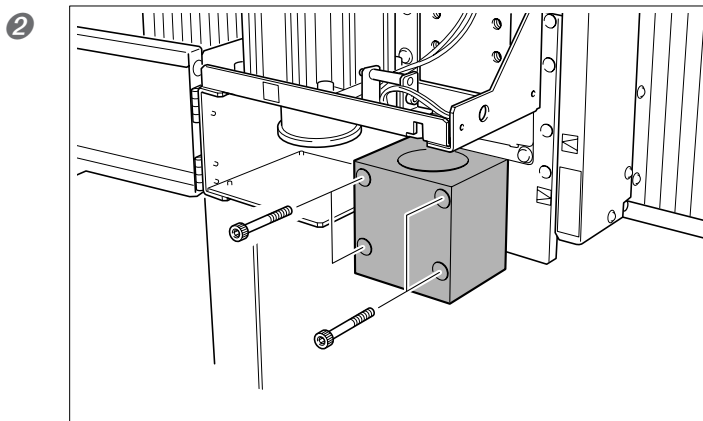

Remove the existing spindle and spindle holder.

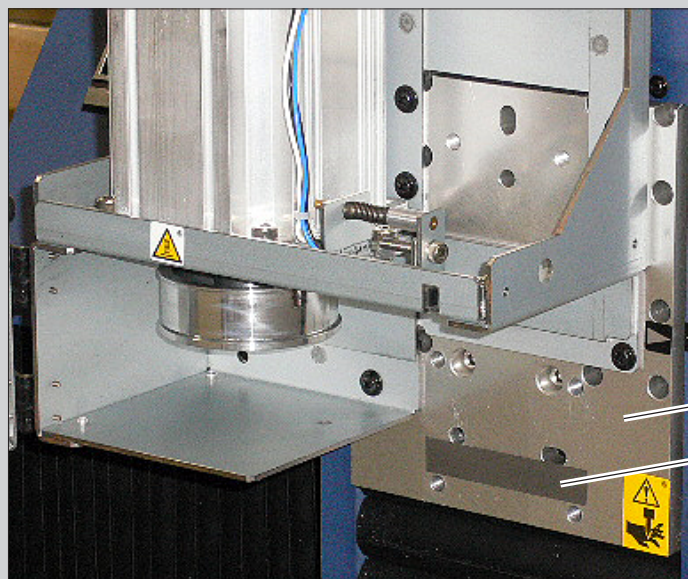
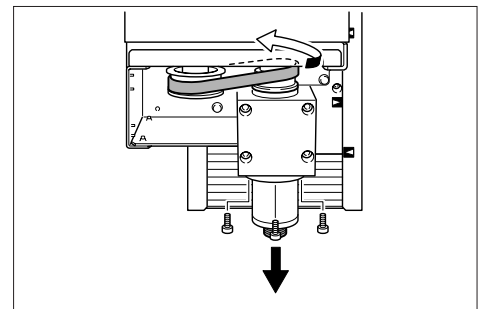

Important Note When Removing the Spindle Holder

A thin spacer (shim) may be present between the spindle holder and the Z-axis rail slider. Reinsert it in its original location, without removing it (step 4). This shim is designed to improve the installation accuracy of the spindle.

Z-axis rail slider

Shim: This must not be removed.

2-4 Step 3: Attach the Spindle and Cylinder

3

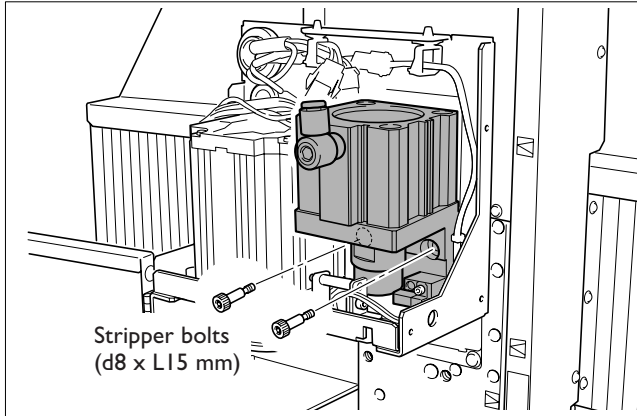

Install the air cylinder.

4

- 1 Pass the belt through the ATC spindle.
 - 2 Attach the ATC spindle. Tighten the cap screws in the sequence shown in the figure.
- For the belt and the cap screws, use the items you removed in step 2.

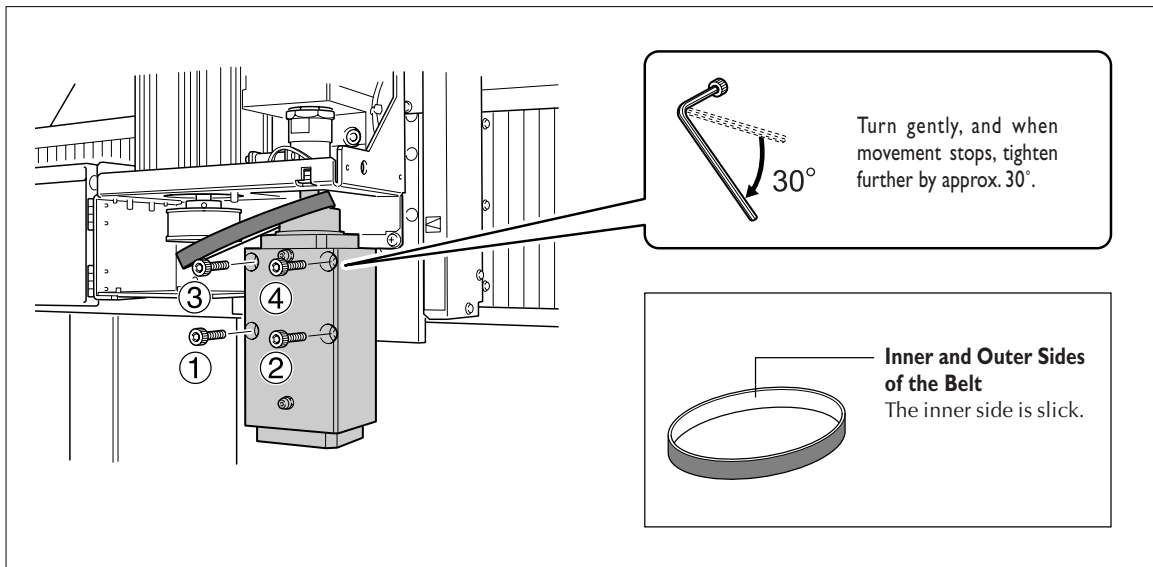

5

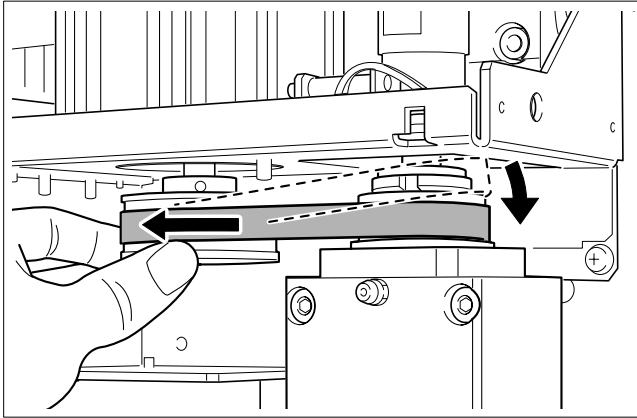

Engage the belt onto the pulley.

6

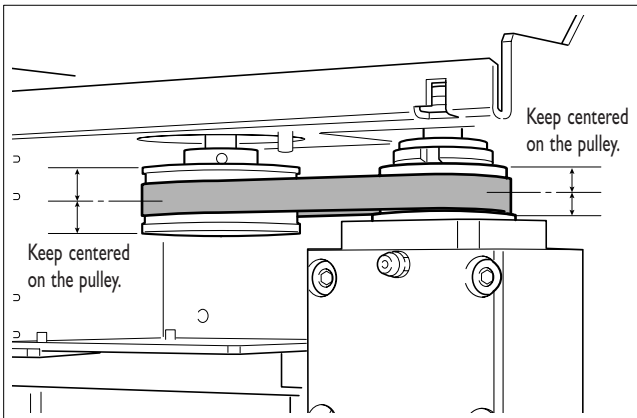

While turning the pulley to break in the belt, keep the belt at the correct position.

Continue by proceeding with "2-5 Step 4: Connect and Secure the Cables."

2-5 Step 4: Connect and Secure the Cables

Connect and Secure the Cables

Procedure

- 1 Secure the cabling connected to the magazine in place with retainers.

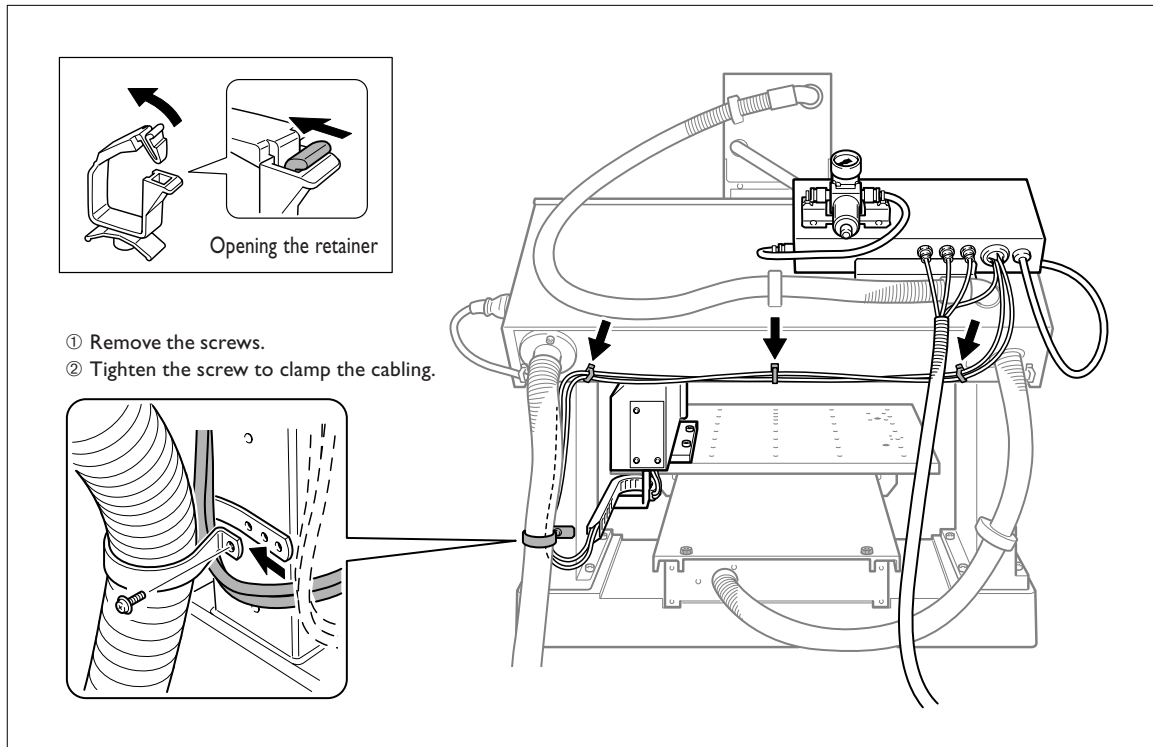

- 2 Arrange the cable hose as shown in the figure.

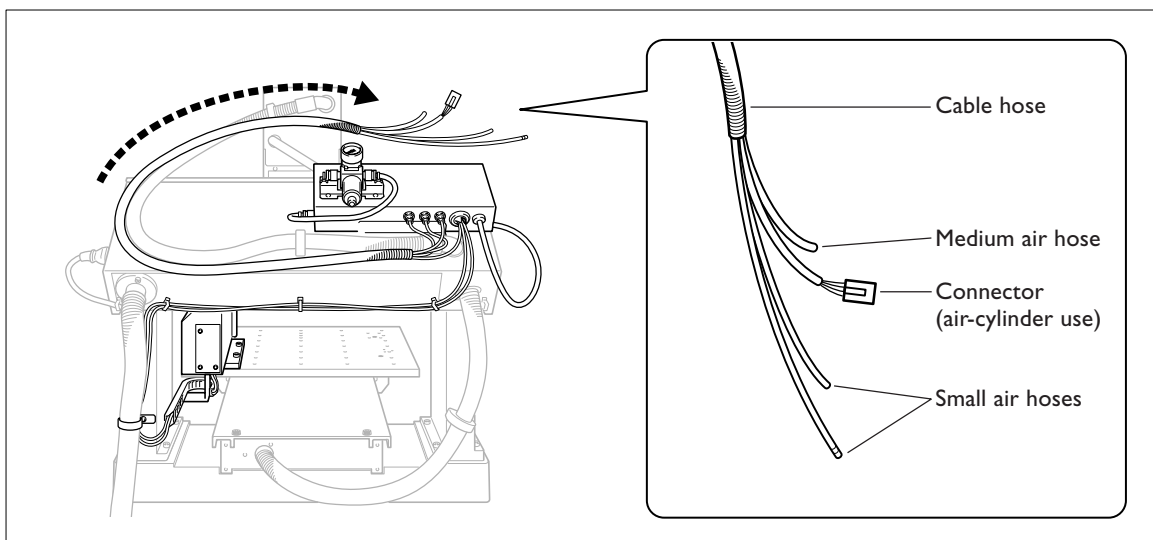

3

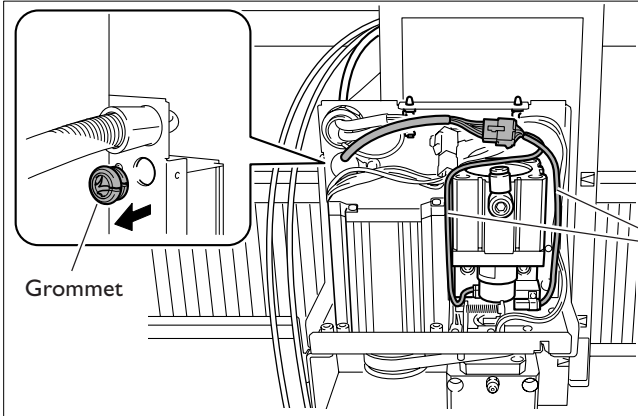

- ① Remove the grommet.
- ② Pass the connector for the air cylinder through the hole.
- ③ Connect the connector.

Pass the cabling for the air cylinder through both sides.

4

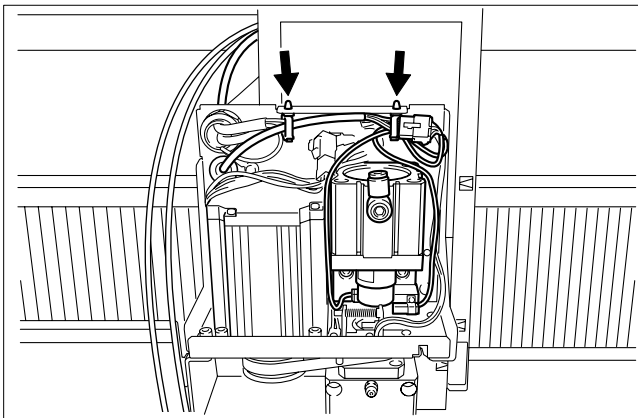

Secure the cabling for the air cylinder in place with retainers.

Be careful to ensure that the cabling does not touch any moving parts.

5

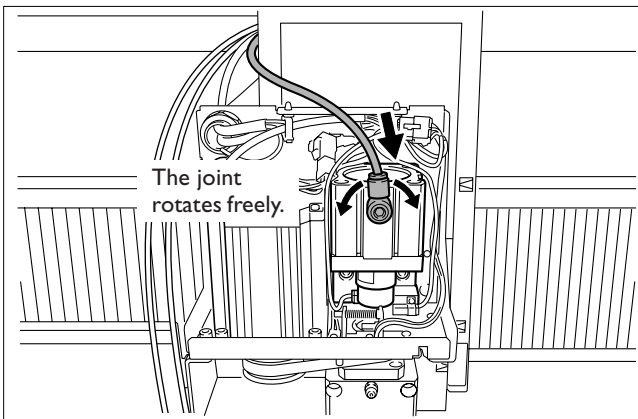

The joint rotates freely.

Connect the medium air hose.

Attaching and detaching the air hose

To connect

Insert firmly as far as it will go.

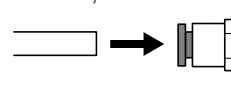

To detach

Press and hold the ring and pull out.

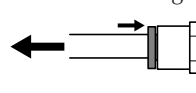

6

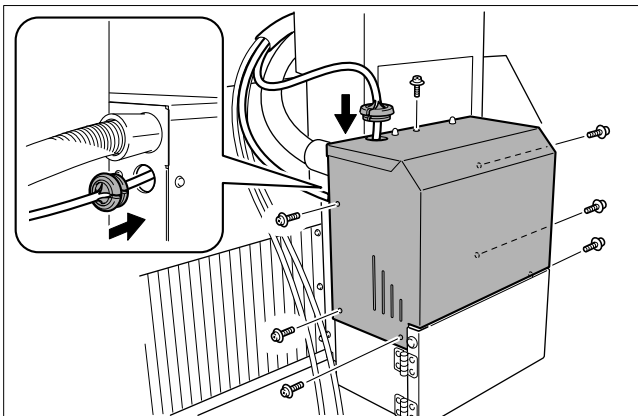

- ① Attach the motor cover at its original location.
- ② Reinsert the two grommets at their original locations.

2-5 Step 4: Connect and Secure the Cables

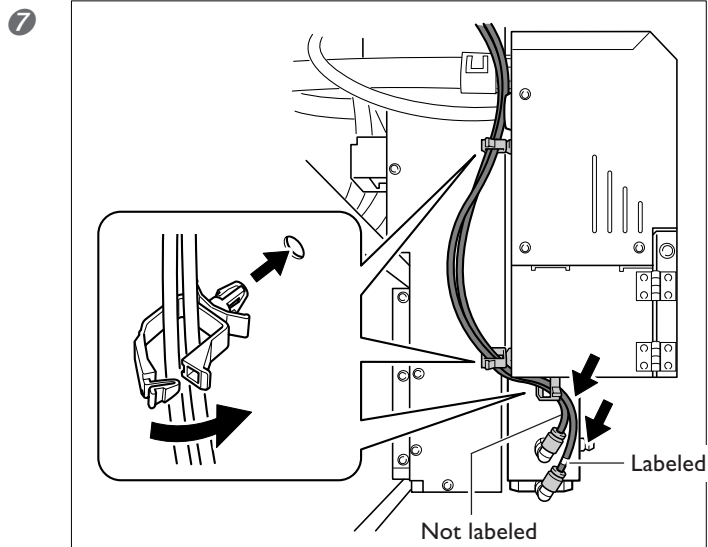

- 1 Attach the cable retainers.
- 2 Connect the two small air hoses.
- 3 Secure the hoses in place with the retainers.

The joint rotates freely.

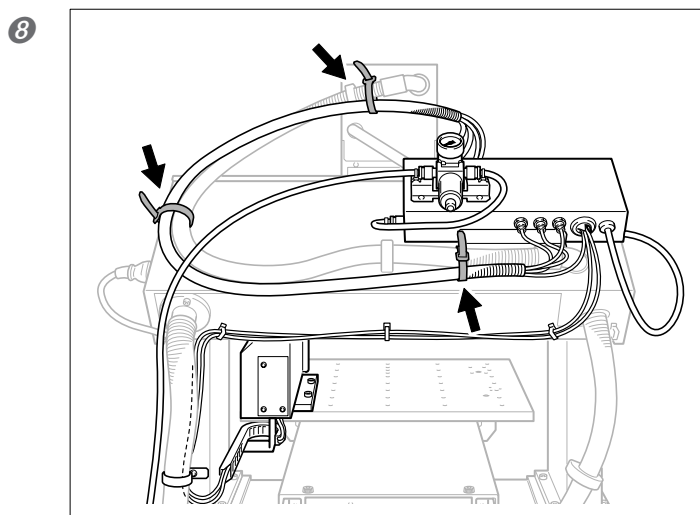

Secure the cable hose in place with large retaining bands.

Ensure that it is not pulled by movement of the spindle.

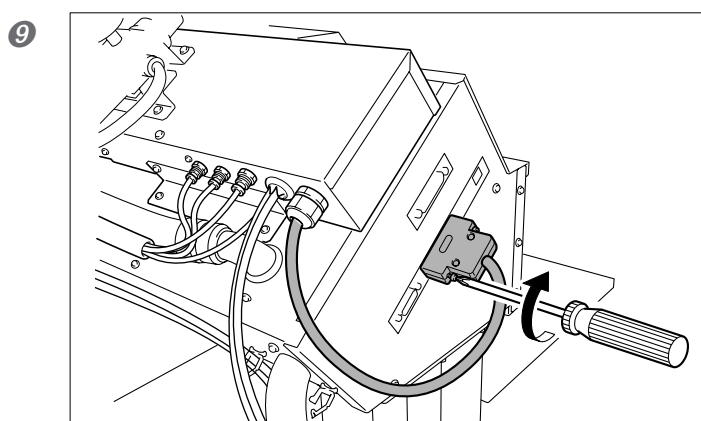

Connect the connector to the modeling machine.

Continue by proceeding with "2-6 Step 5: Supply Compressed Air."

2-6 Step 5: Supply Compressed Air

Supply Compressed Air

⚠ WARNING The pressure of the supplied compressed air must be not more than 1 MPa. Exceeding this may cause rupture or other serious accident.

⚠ WARNING Ensure no contamination of the supplied compressed air by any water, oils, chemicals, or foreign objects. Components may deteriorate or rupture, or the contaminants may be scattered, posing a hazard.

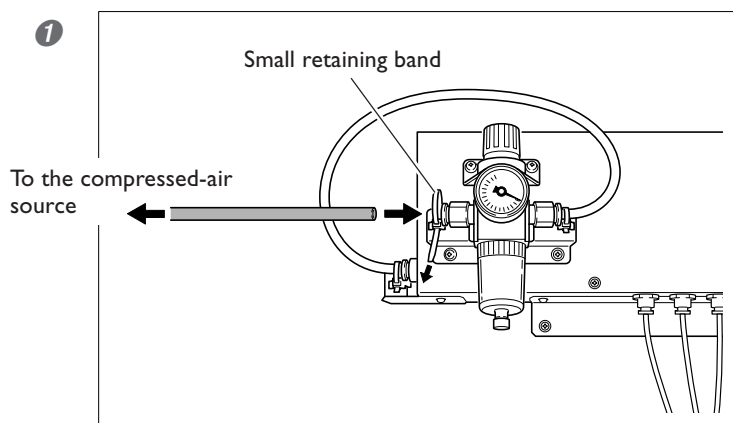

- ① Attach an air hose.
- ② Secure in place with the small retaining band.

Attaching and detaching the air hose

To connect

Insert firmly as far as it will go.

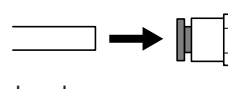

To detach

Press and hold the ring and pull out.

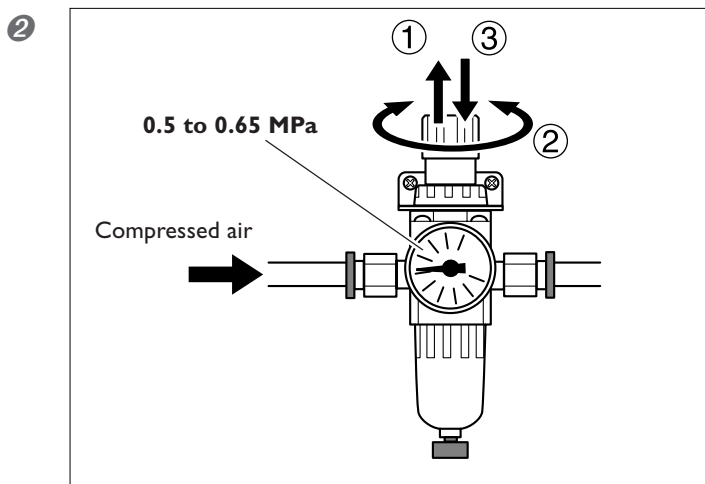
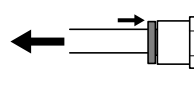

Once compressed air is being supplied, check to make sure no air leaks from connections or other areas.

Next, slowly turn the regulator knob to adjust until the meter reads 0.5 to 0.65 MPa.

Important Note on Adjusting the Pressure

Be sure to adjust to an air pressure of not more than 0.7 MPa. Exceeding this may cause malfunction.

Continue by proceeding with "2-7 Step 6: Adjust the Tool-change Location."

2-7 Step 6: Adjust the Tool-change Location

Adjust the Tool-change Location

Procedure

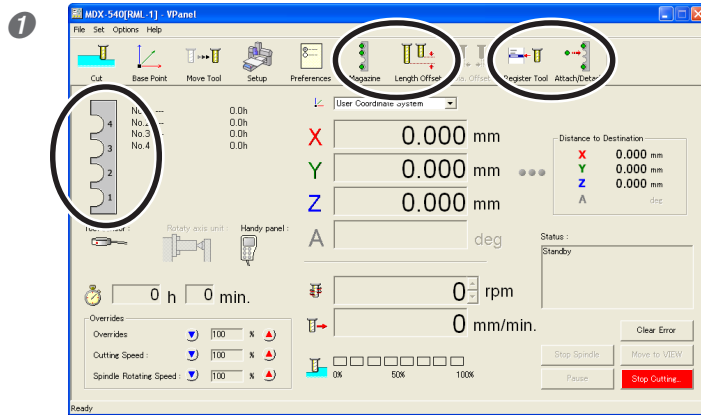

- 1 Start the modeling machine.
- 2 Go to the main window in VPanel and make sure the information for the ATC is displayed.

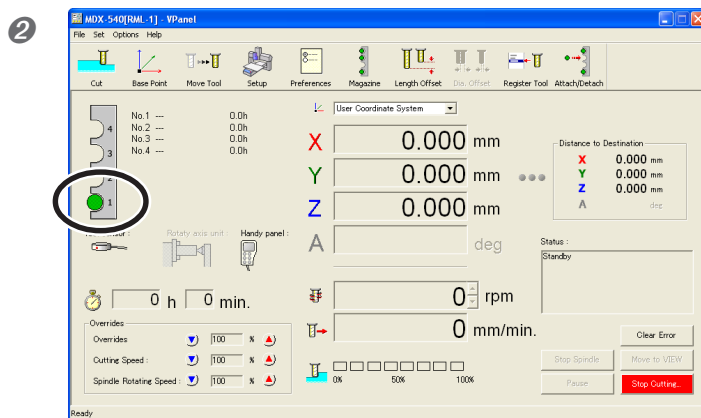

Mount a tool holder in stocker No. 1.

For information on how to mount this, see the following page.

☞ P. 52, "3-2 Mounting the Tool Holders"

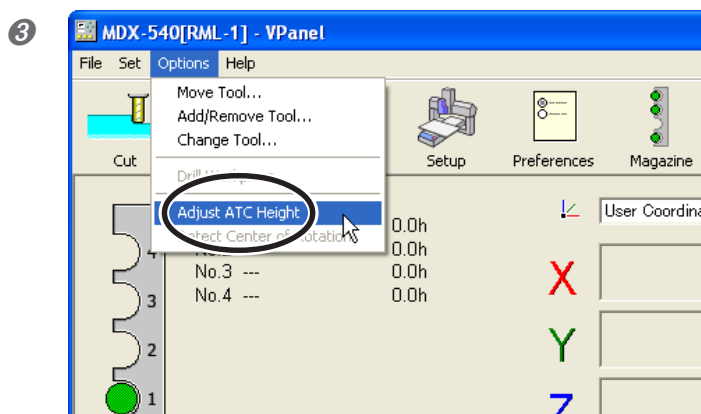

In VPanel, go to the [Options] menu and click [Adjust ATC Height].

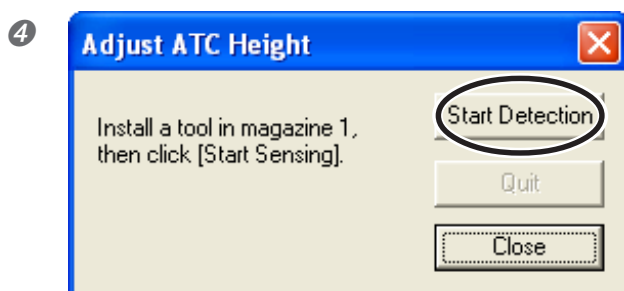

⚠ WARNING: This procedure makes the machine operate. Before you perform this procedure, check to make sure that operation of the machine will not create any hazard or danger. Click [Start Detection].

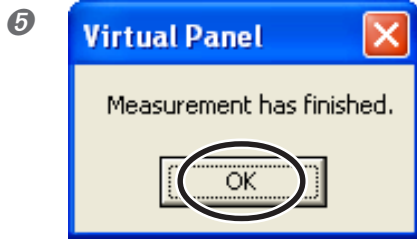

Click [OK] to finish adjustment.

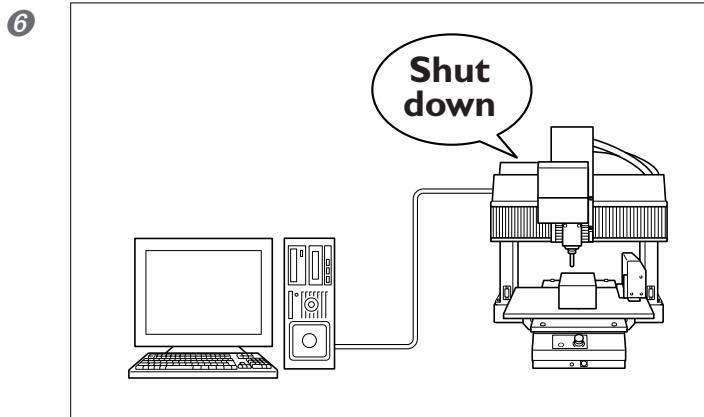

Shut down the modeling machine.

This completes all installation operations.

Chapter 3

Basic Operation

3-1 Starting and Quitting

How to Start the Machine

When this unit is installed, the procedure for starting the modeling machine changes slightly. Initialization cannot be performed while a tool holder remains gripped by the spindle. This means that if a tool holder remains gripped, it must be released when you begin startup. When a tool holder does not remain gripped, the startup procedure does not change.

Procedure

1

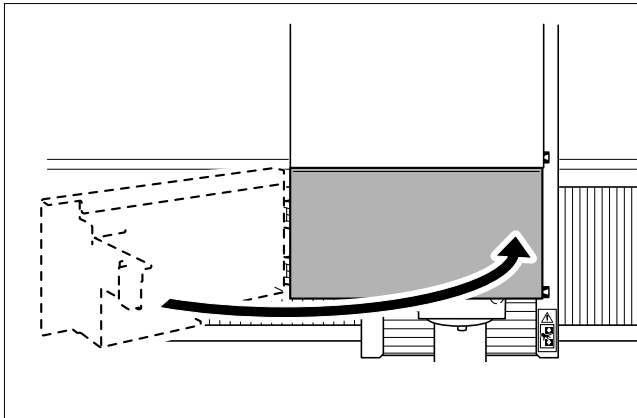

Close the spindle cover.

2

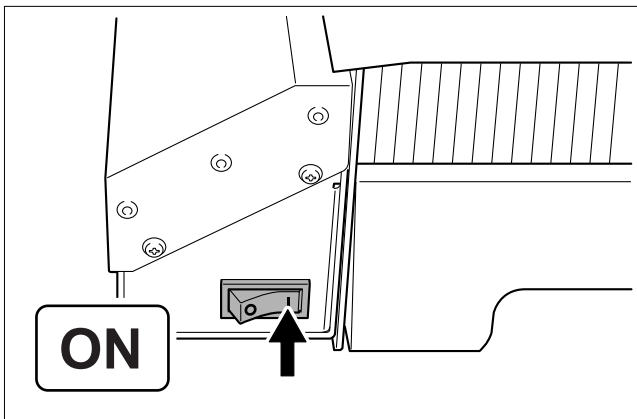

Switch on the power switch.

3

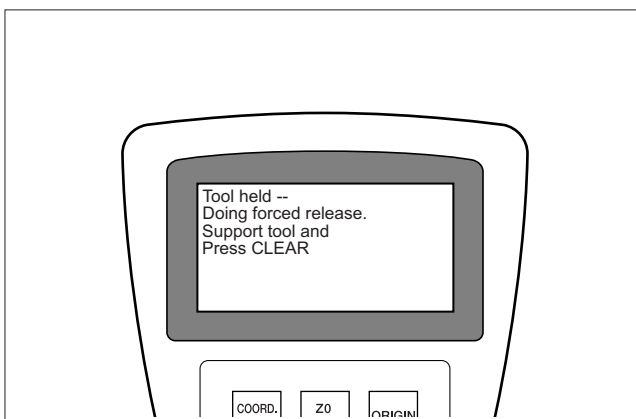

If a tool remains gripped, this screen appears on the handy panel.

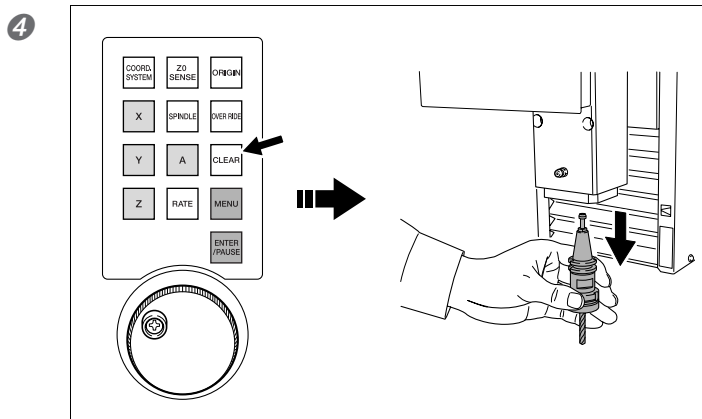

- ① Support the tool with your hand to keep it from falling.
- ② On the handy panel, press the [CLEAR] key.

After the tool holder is released, return to the normal startup procedure. Press the [ENTER] key to perform initialization, then start VPanel.

If No Handy Panel Is Attached

After switching on the power, start VPanel. Following the on-screen instructions displays a window for forced release of the tool holder. Use this to perform the release.

If neither the handy panel nor VPanel is available, the tool holder cannot be released, and so startup is not possible.

How to Shut down

Before shutting down, return the tool holder to the magazine. Whenever possible, avoid shutting down while a tool holder remains gripped.

☞ P. 55, "3-3 Manual Tool-change"

3-2 Mounting the Tool Holders

Mounting Tool Holders in the Magazine

The magazine is a "box" for storing the tool holders you use for cutting. Before you start cutting, load it with the needed tool holders.

Procedure

1

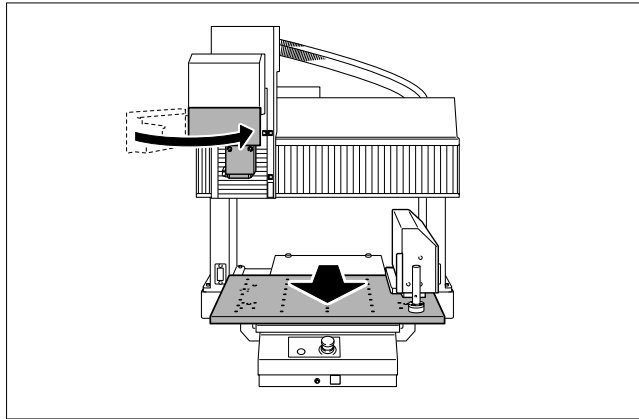

- ① Close the spindle cover.
- ② Perform manual feed to move the table all the way to the front.

2

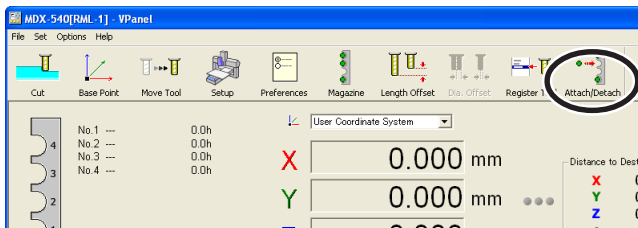

In VPanel, click the [Attach/Detach] icon.

3

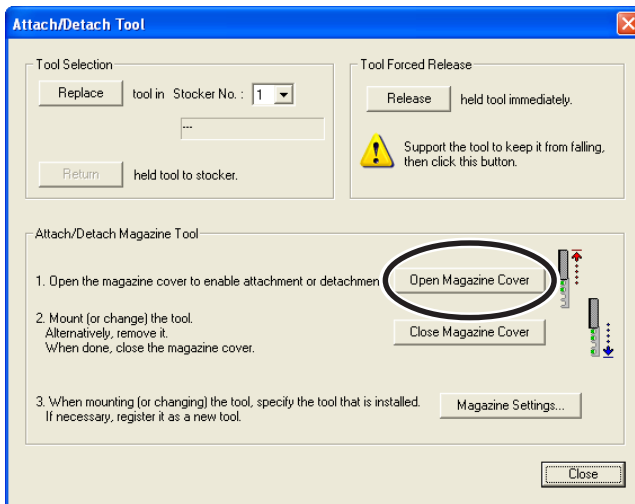

⚠ WARNING: This procedure makes the machine operate. Before you perform this procedure, check to make sure that operation of the machine will not create any hazard or danger. Click [Open Magazine Cover].

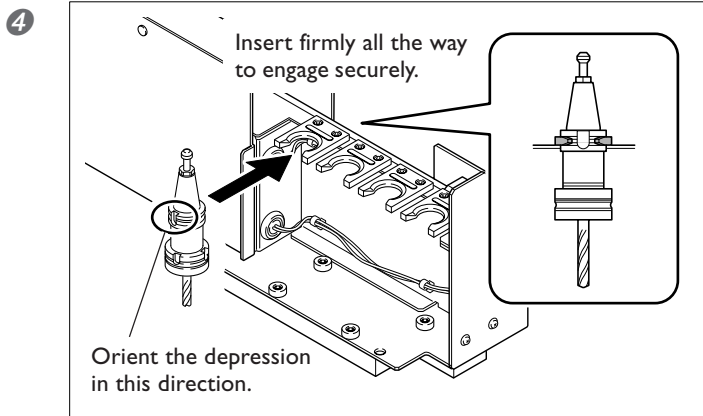

Mount the tool holders in the stockers.

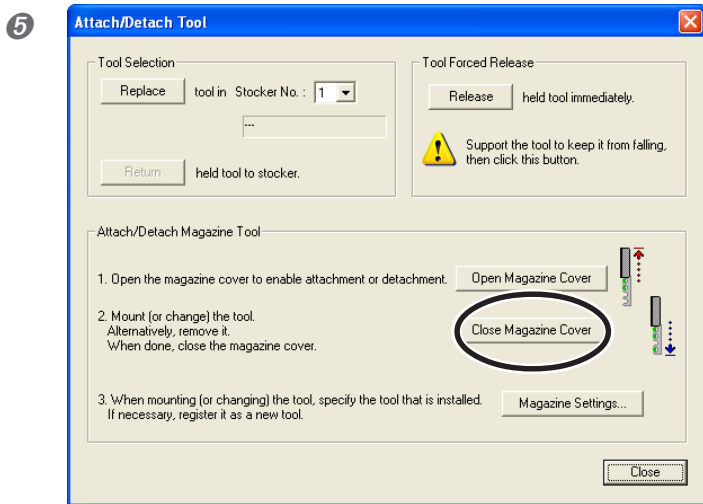

Click [Close Magazine Cover].

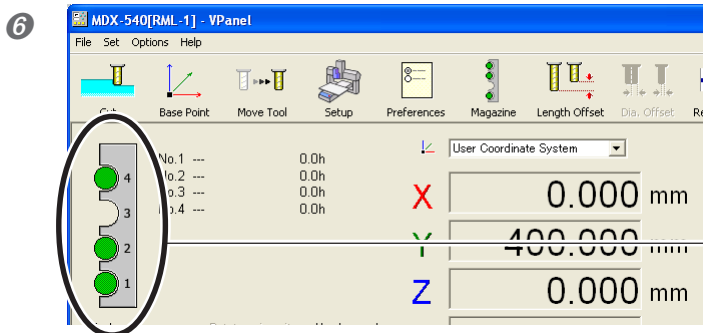

Check the information displayed in VPanel.

The tool holders are displayed in the stockers where they are mounted.

Installing no more than the number required to accomplish cutting is sufficient. Keeping four installed always is not necessary. Also, you are free to mount tool holders in whichever stocker numbers you prefer. It can be convenient to decide on and use a system that is easy to remember, such as mounting a draft-cutting tool holder in stocker No. 1, a semi-finishing tool in No. 2, and so on.

Important Note on the Destination for Tool-holder Return

When the spindle is gripping the tool holder from stocker No. 1, for example, never mount another tool in No. 1. Doing so makes it impossible to return the tool holder currently gripped. This unit employs a fixed-address system, in which a tool holder taken from stocker No. 1 is always returned to No. 1.

Operation Using the Handy Panel

You can also perform this operation using the handy panel.

☞ P.71, "Chapter 6 - Handy Panel"

About the Stocker Numbers

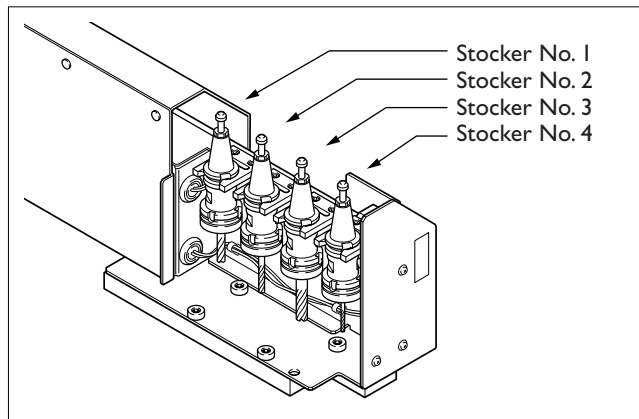

The stockers are numbered from 1 to 4. The tools used for cutting are all specified by these stocker numbers. This makes it important to decide on the numbers where the tool holders are mounted before you perform cutting.

3-3 Manual Tool-change

Grasping a Tool Holder by Manual Operation

Tool-change is performed automatically according to commands from the computer, but when necessary you can also perform tool-change manually. Note, however, that this operation cannot be performed when the spindle cover is open, during a cutting operation, or while the machine is paused.

Procedure

1

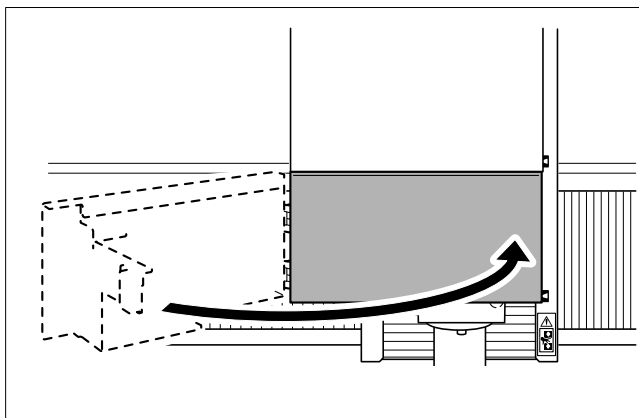

Close the spindle cover.

2

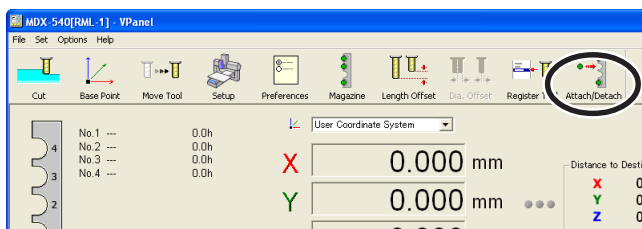

In VPanel, click the [Attach/Detach] icon.

3

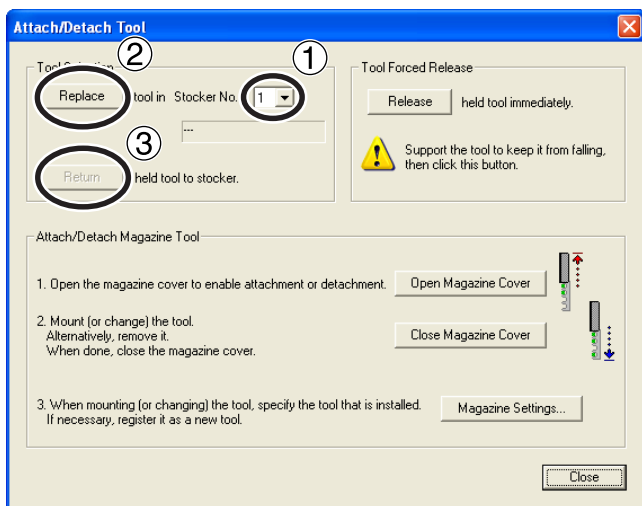

WARNING: This procedure makes the machine operate. Before you perform this procedure, check to make sure that operation of the machine will not create any hazard or danger.

- ① Choose the stocker number.
- ② Click [Replace].
- ③ To return, click [Return].

Operation Using the Handy Panel

You can also perform this operation using the handy panel.

☞ P.71, "Chapter 6 - Handy Panel"

Chapter 4

Tool-length Offset

4-1 What's the Tool-length Offset?

What's the Tool-length Offset?

This feature keeps the position of the tool tip from changing during cutting, even when you change among tools of different lengths. This is useful when you want to use multiple tools selectively to cut a single workpiece.

Note, however, that this requires measuring the lengths of the respective tools and saving their adjustment (offset) values in advance. The figure below shows an example where the gauge surface of the tool holders is used as the reference.

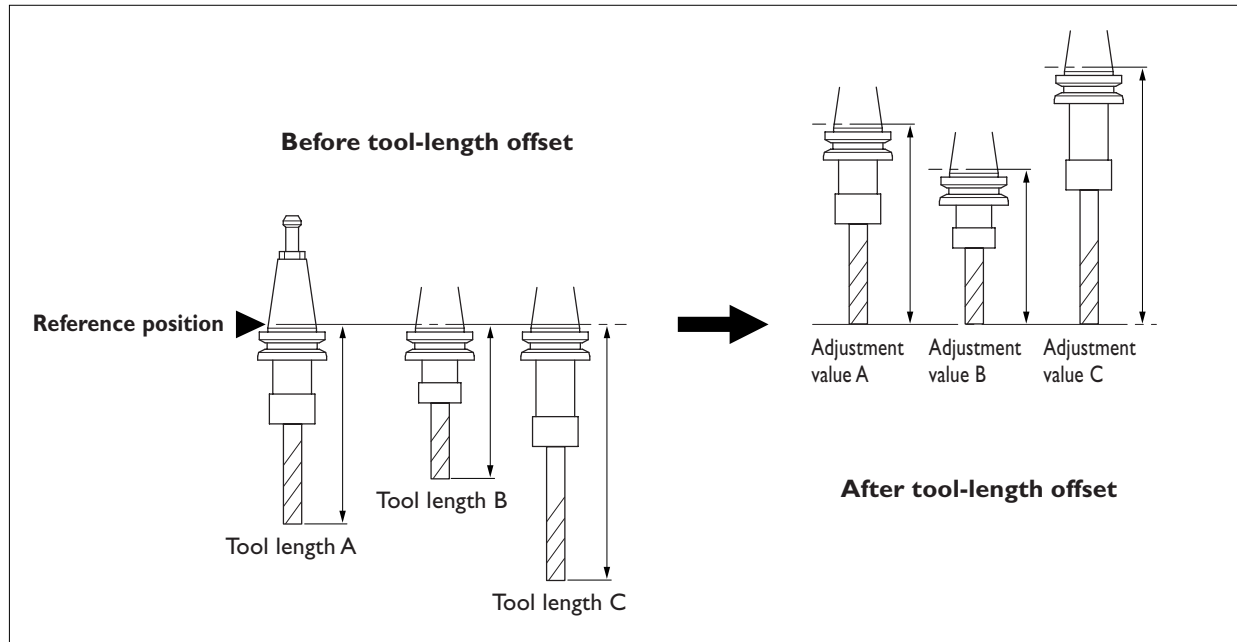

Tool-length Automatic-measurement Feature

This unit also provides a feature for measuring the tool length automatically. Using this can be convenient because it performs all tasks up through saving the adjustment value in a single step.

☞ P. 59, "4-2 Automatic Measurement of Tool Length"

How to Determine the Adjustment Values

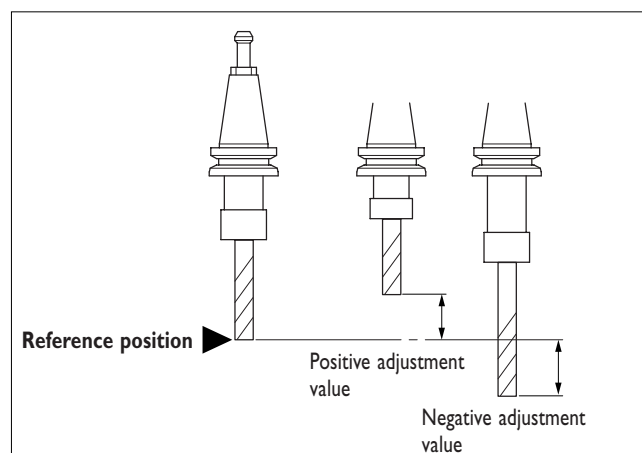

When you measure tool length yourself, you make the distance from the reference position to the tool tip the adjustment (offset) value. However, it's best to decide on a clearly defined reference position. This figure shows an example where you decide on the reference tool and use the position of its tool tip as the reference. (In this case, the adjustment value for the reference tool is zero.)

It's important to note that adjustment values may be positive or negative. The value is positive when the tip is lower than the reference position or negative when higher than reference position.

☞ P. 62, "4-3 Entering Adjustment Values Yourself"

4-2 Automatic Measurement of Tool Length

What's Automatic Measurement of Tool Length?

This feature automatically measures tool length using the Z-origin sensor and registers its adjustment value. You can perform batch registration for a number of tools at one time.

Automatic-measurement Procedure

Procedure

1

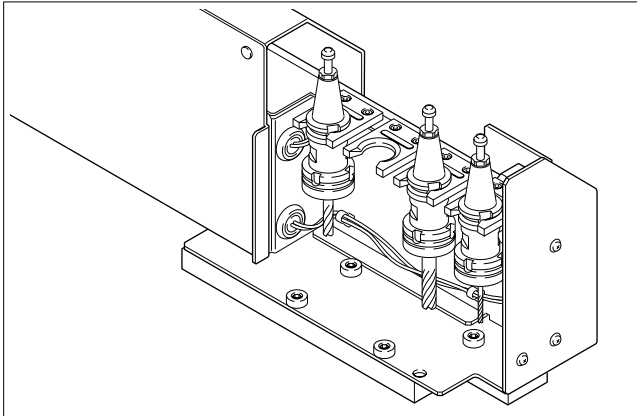

Mount tool holders in the magazine.

2

Make the cable connection to the Z-origin sensor.

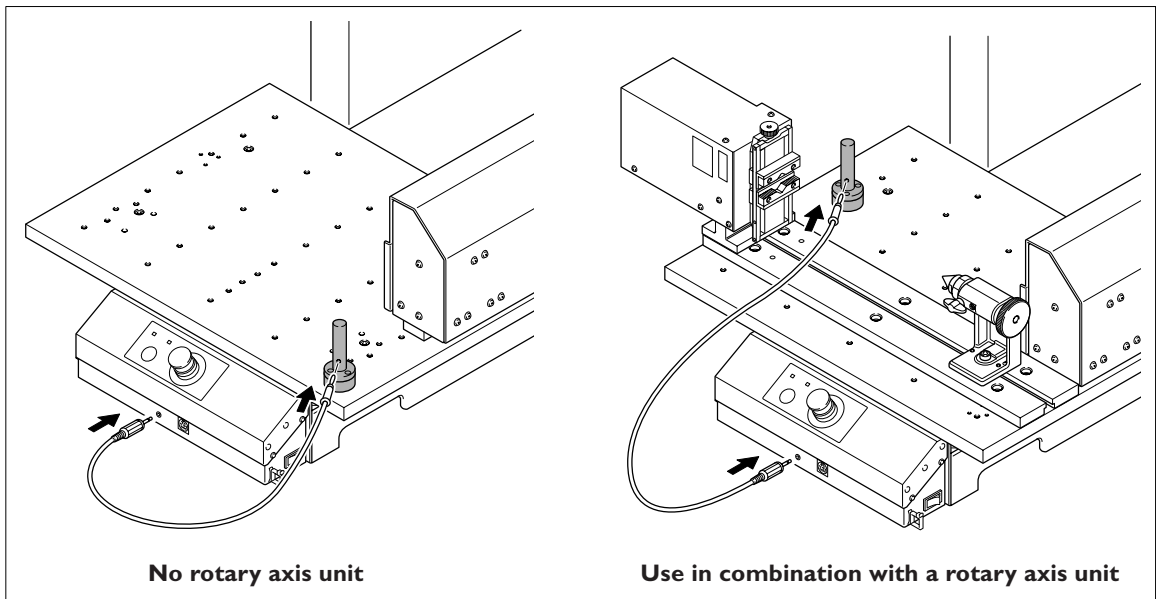

No rotary axis unit

Use in combination with a rotary axis unit

4-2 Automatic Measurement of Tool Length

3

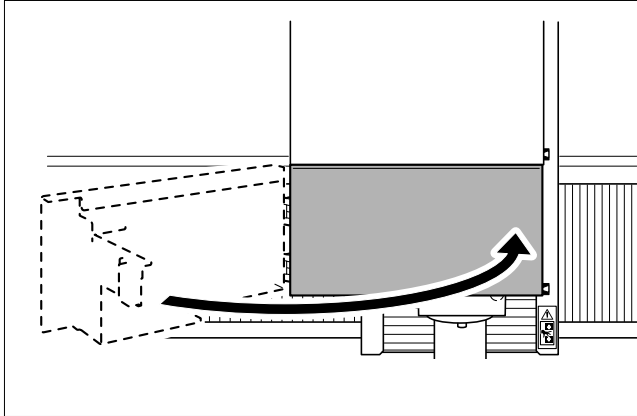

Close the spindle cover.

4

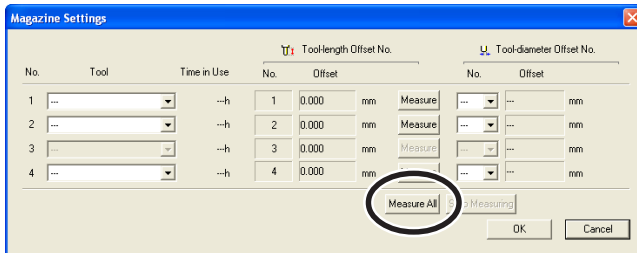

- ① In VPanel, click the [Magazine] icon.
- ② Click [Measure All].

5

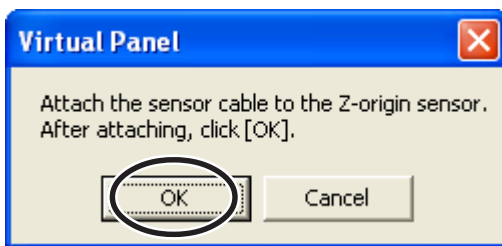

⚠ WARNING: This procedure makes the machine operate. Before you perform this procedure, check to make sure that operation of the machine will not create any hazard or danger. Click [OK].

6

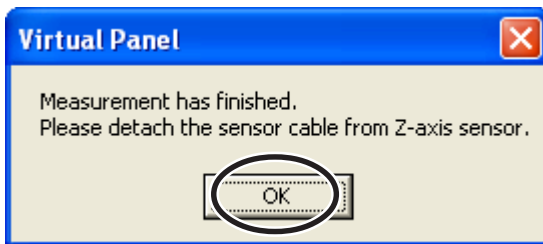

- ① Click [OK] to finish measuring.
- ② Detach the sensor cable.

This completes the registration of the adjustment values and the preparations for starting tool-length offset. To use tool-length offset in actual operations, refer to the pages indicated below.

☞ P. 68, "5-2 Examples of Usage of Tool-length Offset (RML-I Mode)"

☞ P. 69, "5-3 Examples of Usage of Tool-length Offset (NC-code Mode)"

⚠ WARNING After performing automatic measurement of tool length, never needlessly perform replacement with a different tool.

Doing so makes the adjustment value incompatible with the tool length, which may result in cutting-in at an unintended depth. Errors or mistakes may cause the tool to break and be thrown off forcefully, leading to danger of injury.

To Make the Tool Descend Rapidly

When it takes a long time for the tool to make contact with the sensor, turn the hand wheel on the handy panel counterclockwise. Be careful not to make the tool collide with the sensor. A collision makes accurate detection impossible. If a collision occurs, redo the operation from the beginning.

Operation Using the Handy Panel

You can also perform this operation using the handy panel.

☞ P.71, "Chapter 6 - Handy Panel"

4-3 Entering Adjustment Values Yourself

Entering Adjustment Values

When you've measured tool length yourself, follow the procedure below to register the adjustment values.

Procedure

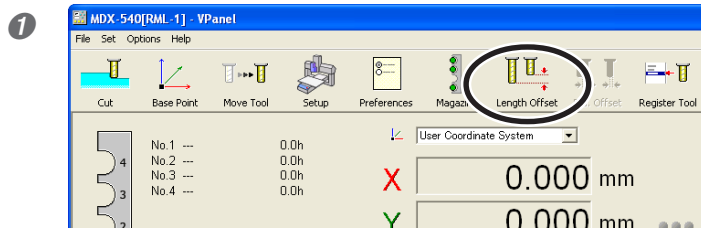

In VPanel, click the [Length Offset] icon.

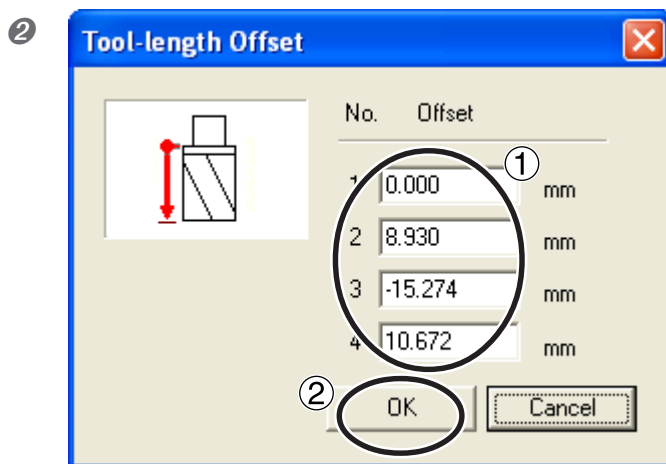

- ① Enter the adjustment value.
- ② Click [OK].

About the Offset Numbers

The numbers displayed in the [Length Offset] dialog box are the offset numbers. In the NC-code mode, the offset numbers may not necessarily be identical to the stocker numbers. It's important to remember that, for example, offset No. 2 may be assigned to stocker No. 1. In the RML-1 mode, it's not necessary to be aware of any differences between stocker numbers and the offset numbers.

☞ P. 64, "Correspondences Between Stocker Numbers and Offset Numbers"

Fine-tuning the Results of Automatic Measurement of Tool Length

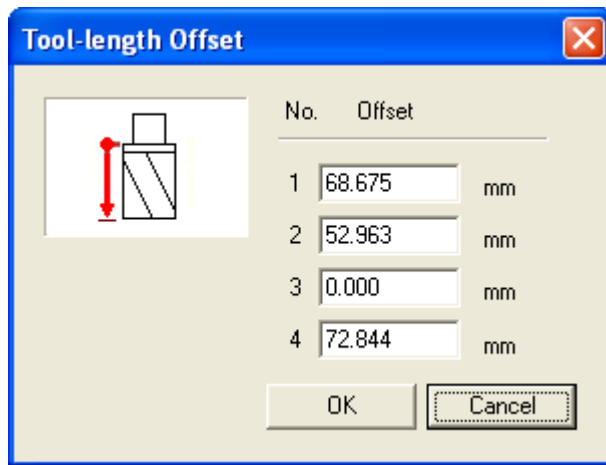

When necessary, you can fine-tune the adjustment values obtained by automatic measurement of tool length. The [Length Offset] dialog box is updated with the results of automatic measurement, so you change the values here.

☞ P. 59, "4-2 Automatic Measurement of Tool Length"

A tool that is longer than the adjustment value performs cutting-in that is deeper than intended. In such cases, increase the value. Conversely, if the cutting-in depth is too shallow, reduce the value.

4-4 Starting Tool-length Offset

When Tool-length Offset Starts

Tool-length offset is activated in the following cases. In each of these cases, the offsets are applied according to the registered adjustment values. (You can use the [Magazine] dialog box to view and check the adjustment values.) Note, however, that the adjustment values are all zero by default, and unless you change them, no offsets are applied.

RML-I Mode

In the RML-1 mode, offsets are always applied according to the registered adjustment values. The offset is applied when a tool-grasping operation is performed, whether according to a command from the computer or by a manual tool-change.

NC-code Mode

In the NC-code mode, no offsets are applied unless an offset-start command is given in the NC program. Note, however, that offsets are applied only during manual feed after a manual tool-change.

Tool-length Offset in a Manual Tool-change

The following events occur as a result of offset application due to a manual tool-change.

Manual Feed

The Z-axis coordinate view is updated to reflect the tool-length offset.

Cutting Operations in the RML-I Mode

If the program you're using doesn't support the ATC (that is, if it's a program incapable of automatic tool-change), you can still perform cutting by grasping the tool using manual tool-change. Tool-length offset is applied at this time as well. Note, however, that this does not occur in the NC-code mode.

Correspondences Between Stocker Numbers and Offset Numbers

RML-I Mode

Being aware of any differences between stocker numbers and offset numbers is not necessary. In the RML-1 mode, the stocker numbers and the offset numbers are always identical.

NC-code Mode

In the NC-code mode, it's necessary to be aware of any differences between stocker numbers and offset numbers. For instance, offset No. 2 may be assigned to stocker No. 1. The combinations are all specified by the NC program.

Manual Tool-change

In manual tool-changes, the stocker number and the offset number are always the same. Offset No. 2, for example, can never be assigned to stocker No. 1, not even in the NC-code mode.

Chapter 5
Getting Ready for and
Performing Cutting

5-1 Cutting Area

Workpiece Size and Location Where Secured in Place

Arrange the workpiece (the material to cut), frames, and the like so that they fit within the determined range. Anything extending beyond may strike moving parts. Be sure to observe this requirement, as failure to do so may result in damage to the workpiece or frame or malfunction of the machine.

⚠️WARNING: Failure to comply may lead to danger of injury by a broken tool thrown out with force.

Standard Table

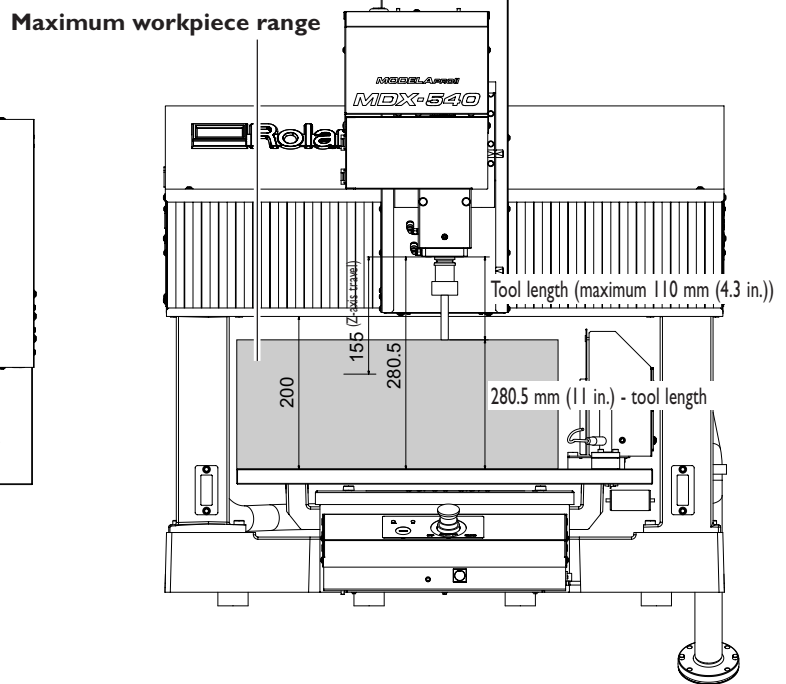
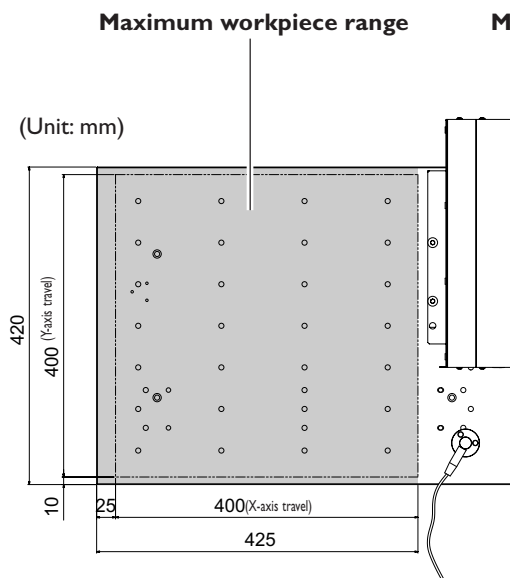

T-slot Table (Optional)

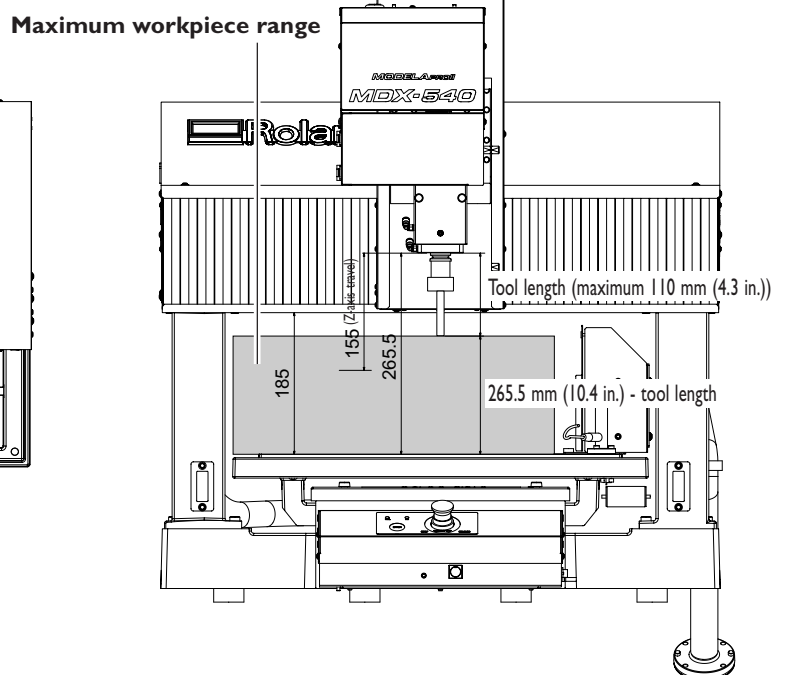
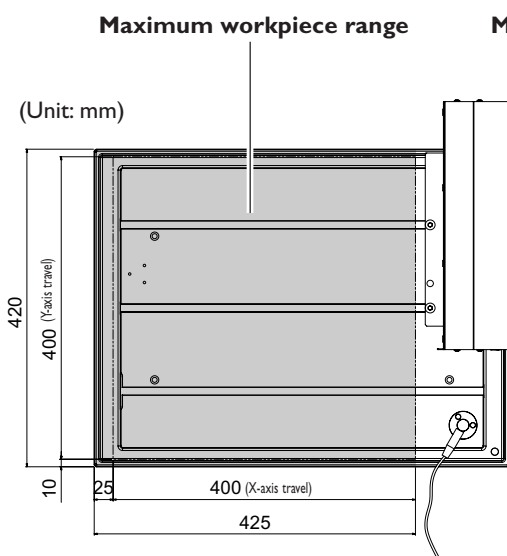

Actual Size That Can Be Cut

Creating an object of the size of the full axis travel is not necessarily possible. Because a certain amount of clearance in the X-, Y-, and Z-axis directions is required for no-load feed of the tool, the allowable size of the workpiece is reduced by a corresponding amount. Also, the possible cutting-in depth is generally determined by the length of the tool. Using a lengthy tool to achieve deep cutting reduces the clearance in the Z-axis direction, which further reduces the allowable size of the workpiece.

The size of what you can cut varies according to the shape of the object you want to create and the tool you use. Give careful thought to this ahead of time, before you start work.

5-2 Examples of Usage of Tool-length Offset (RML-I Mode)

Example of Operations up to Starting Cutting

This section explains some important points about using an ATC-compatible program to perform cutting with multiple tools.

Mount the Tools

Decide on the tools to use for draft cutting, finishing, and so on, and mount them in the magazine. Once you've mounted them, it's important not to replace them with others until after you've finished cutting.

☞ P. 52, "3-2 Mounting the Tool Holders"



Register the Adjustment Values

Use automatic measurement of tool length or another method to register the adjustment values.

☞ P. 57, "Chapter 4 - Tool-length Offset"



Make the Program Settings

Use the stocker numbers specify which tools to use and when to use them.



Set the Z-axis Origin

It's a good idea to set the Z-axis origin only after you've registered the adjustment values. It's sufficient to make the setting for just one of the tools in the magazine. For more information, refer to the following section.

☞ P. 68, "Example of Setting the Z-axis Origin"



Start Cutting

When you send the cutting data, the tool specified by the program is grasped and cutting starts. The tool-length offset is applied at this time, and the cutting-in depth stays the same even after changing to the next tool.

Example of Setting the Z-axis Origin

Procedure

- 1 Use manual tool-change to grasp any one of the tools.
You may grasp any tool whose adjustment value has already been registered.
- 2 Set the Z-axis origin for the gripped tool.
Do this regardless of whether blade alignment was performed manually or by using a tool sensor.
- 3 Return the tool to the magazine.

5-3 Examples of Usage of Tool-length Offset (NC-code Mode)

Example of Operations up to Starting Cutting

This section explains some important points about using an NC program to perform cutting with multiple tools.

Mount the Tools

Decide on the tools to use for draft cutting, finishing, and so on, and mount them in the magazine. Once you've mounted them, it's important not to replace them with others until after you've finished cutting.

☞ P. 52, "3-2 Mounting the Tool Holders"



Register the Adjustment Values

Use automatic measurement of tool length or another method to register the adjustment values.

☞ P. 57, "Chapter 4 - Tool-length Offset"



Specify the Commands in the NC Program

Specify the tools to use by their stocker numbers. At the same time, also specify the offset numbers assigned to the corresponding stocker numbers. Depending on the NC program, offset No. 2, for example, may be assigned to stocker No. 1, making the settings complex. Normally you should assign offset No. 1 to stocker No. 1, offset No. 2 to stocker No. 2, and so on.

☞ "NC Code Reference Manual"



Set the Z-axis Origin

It's a good idea to set the Z-axis origin only after you've registered the adjustment values. It's sufficient to make the setting for just one of the tools in the magazine. For more information, refer to the following section.

☞ P. 70, "Example of Setting the Z-axis Origin"



Start Cutting

When you send the cutting data, the tool specified by the program is grasped and cutting starts. The tool-length offset is applied at this time, and the cutting-in depth stays the same even after changing to the next tool.

Example of Setting the Z-axis Origin

Procedure

- ① **Use manual tool-change to grasp any one of the tools.**
You may grasp any tool whose adjustment value has already been registered.
- ② **Set the Z-axis origin for the gripped tool.**
Do this regardless of whether blade alignment was performed manually or by using a tool sensor.
- ③ **Return the tool to the magazine.**

Important Note on Setting the Z-axis Origin

The procedure described above is valid only when offset No. 1 is assigned to stocker No. 1, offset No. 2 is assigned to stocker No. 2, and so on. Even when you want to make no associations between stocker numbers and offset numbers, it's necessary for the stocker number to be identical to the offset number for at least one tool. Set the Z-axis origin for a tool whose stocker number and offset number are the same.

Chapter 6

Handy Panel

6-1 Features Added to the Handy Panel

Features Added to the Handy Panel

Installing this unit adds the following features to the handy panel.

- > Opening and closing the magazine cover
- > Manual tool-change
- > Tool forced release
- > Automatic measurement of tool length

The handy panel automatically detects when this unit is installed. You don't need to make any special settings.

6-2 Manual Operation of the ATC

Basic Operation of the ATC

You can perform basic operation of the ATC using the handy panel. Note, however, that this operation cannot be performed when the spindle cover is open, during a cutting operation, or while the machine is paused.

☞ P. 49, "Chapter 3 - Basic Operation"

Procedure

1

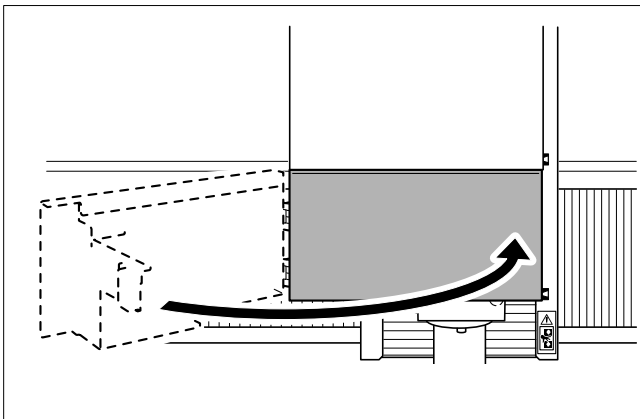

Close the spindle cover.

2

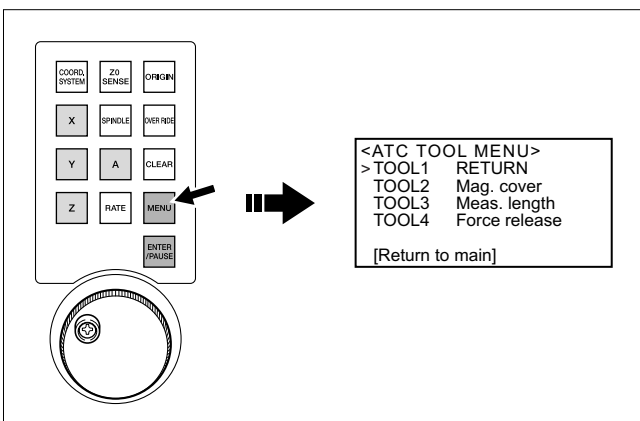

Press the [MENU] key several times to display [ATC TOOL MENU].

3

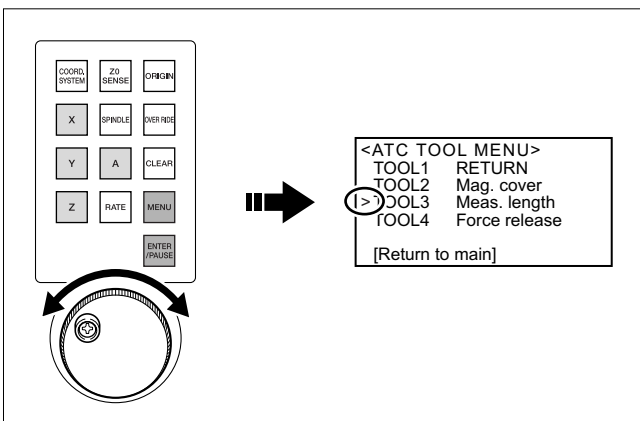

Use the hand wheel to select the item.

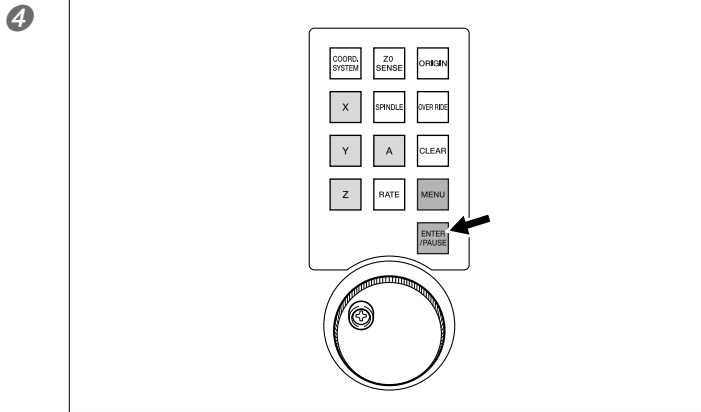

⚠ WARNING: This procedure makes the machine operate. Before you perform this procedure, check to make sure that operation of the machine will not create any hazard or danger. Press the [ENTER] key.

To go back to the original screen, use the hand wheel to select [Return to main], then press the [ENTER] key.

About the Selection Items

- > **TOOL 1 through TOOL 4:** This grasps the tool holder.
- > **RETURN:** This returns the tool holder to the magazine.
- > **MAGAZINE COVER:** This opens or closes the magazine cover.
- > **LENGTH SCAN:** This executes automatic measurement of tool length.
- > **FORCED RELEASE:** This performs a forced release of the tool holder. Perform the operation while supporting the tool holder with your hand to keep it from falling.

Automatic Measurement of Tool Length

This performs the same operation as going to VPanel's [Magazine] dialog box and clicking the [Measure All] button. For detailed information about automatic measurement of tool length, refer to the page indicated below.

☞ P. 59, "4-2 Automatic Measurement of Tool Length"

Chapter 7

Appendix

7-1 Daily Care

Cleaning

⚠️ WARNING Before attempting cleaning, maintenance, or attachment or detachment of the air hose or any optional items, stop the supply of compressed air and allow the pressure to escape.

Allowing the equipment to remain under pressure poses a hazard of flying components.

⚠️ WARNING Never use a pneumatic blower.

This machine is not compatible with a pneumatic blower. Cutting waste may get inside the machine and cause fire or electrical shock.

⚠️ WARNING Never use a solvent such as gasoline, alcohol, or thinner to perform cleaning.

Doing so may cause fire.

⚠️ WARNING Disconnect the power cord before performing cleaning or maintenance.

Attempting such operations while the machine is connected to a power source may result in injury or electrical shock.

⚠️ WARNING When using a vacuum cleaner to take up cutting waste, exercise caution to prevent fire or dust explosion.

Taking up fine cuttings using an ordinary vacuum cleaner may cause danger of fire or explosion. Check with the manufacturer of the vacuum cleaner. When the safety of use cannot be determined, clean using a brush or the like, without using the vacuum cleaner.

⚠️ CAUTION Caution: high temperatures.

The cutting tool and spindle motor become hot. Exercise caution to avoid fire or burns.

➤ Carefully clean away cutting waste. Operating the machine with a large amount of cutting waste present may cause malfunction.

➤ Never apply lubrication anywhere except at specified locations.

Bleeding Off Air Pressure

⚠️ WARNING Before attempting cleaning, maintenance, or attachment or detachment of the air hose or any optional items, stop the supply of compressed air and allow the pressure to escape.

Allowing the equipment to remain under pressure poses a hazard of flying components.

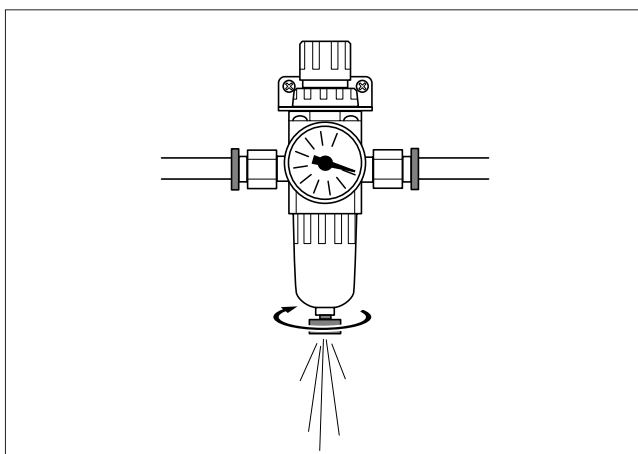

First, stop the supply of compressed air, and loosen the knob at the bottom of the air regulator a little at a time. Material may spray out of the drain at this time. Use a cloth or the like to catch the spray and keep it from scattering. After allowing the air to escape, retighten the knob.

Cleaning Inside the Magazine Cover

Open the magazine cover and clean away any buildup of cutting waste inside. For information on how to open the magazine cover, refer to the following.

☞ P. 52, "Mounting Tool Holders in the Magazine"

Care and Maintenance of the Tool Holders and Spindle Nose

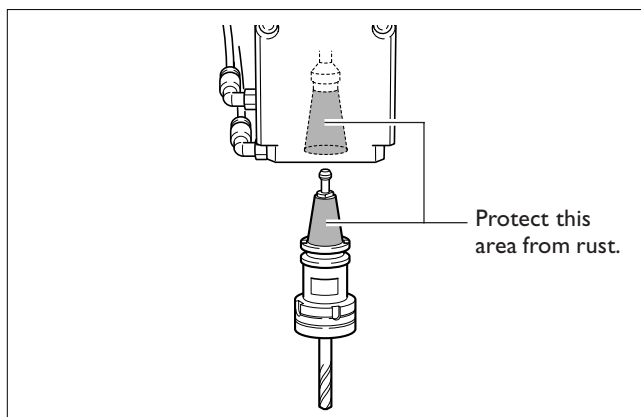

Before use, clean away any cutting waste and excess grease. Failure to do so may affect runout precision or cause slippage.

Perform maintenance diligently to prevent rust. Thoroughly wipe off any skin oils or the like with a cleaning rag. When the machine is to be taken out of use for some time, apply machine oil to prevent rust.

Adjusting the Air Pressure

Before starting operations, check to make sure the reading on the meter for the air regulator is within the specified range, and adjust as required.

☞ P. 45, "2-6 Step 5: Supply Compressed Air"

Care and Maintenance of the Air Regulator

⚠️ WARNING Before removing the bowl, be sure to bleed off the air pressure. Failure to do so may cause danger of rupture or thrown-off parts.

⚠️ WARNING Clean the bowl using a neutral detergent. Never use gasoline, alcohol, thinner, or any other solvent. Using a solvent may degrade the bowl and cause danger of rupture.

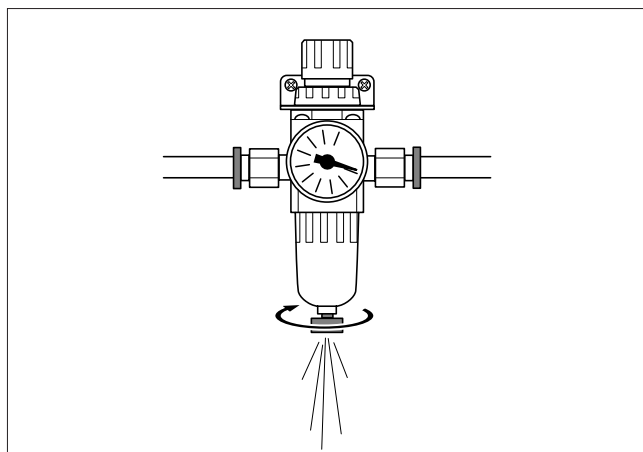

The air regulator is equipped with a filter that becomes filled with trapped material (moisture and dust) over time. Periodically empty the drain. First, stop the supply of compressed air, and loosen the knob at the bottom of the air regulator a little at a time. Material may spray out of the drain at this time. Use a cloth or the like to catch the spray and keep it from scattering. When the drain is emptied, retighten the knob.

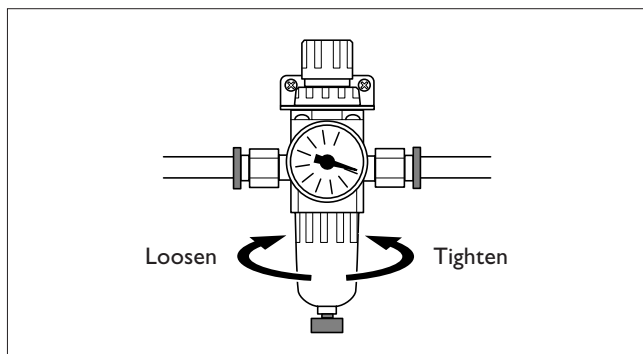

If the interior of the bowl becomes soiled, remove the bowl and wash it using a neutral detergent.

7-2 Inspection and Maintenance

Checking the Total Working Time

This machine automatically keeps track of time in operation. Use this as a general guide for determining when to perform maintenance.

The time for which the spindle has rotated is taken to be the working time.

- 1 In VPanel, click the [Setup] icon.
- 2 Click the [Modeling Machine] tab.

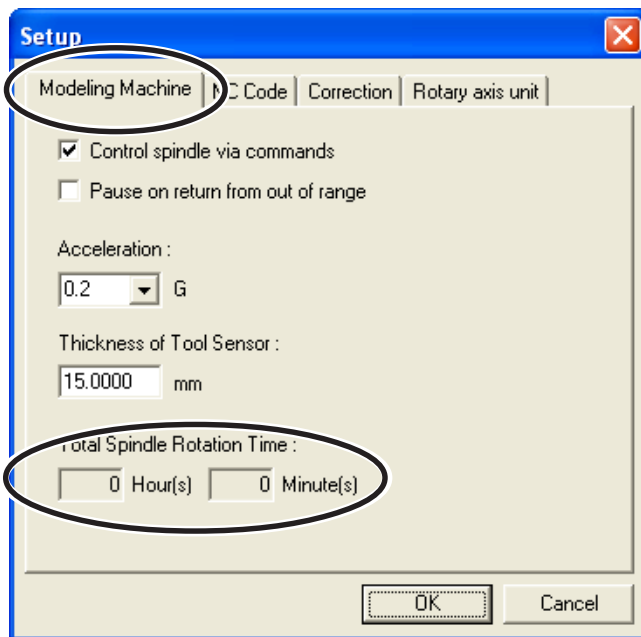

Lubricating the Spindle

- ⚠ WARNING** Disconnect the power cord before performing cleaning or maintenance. Attempting such operations while the machine is connected to a power source may result in injury or electrical shock.

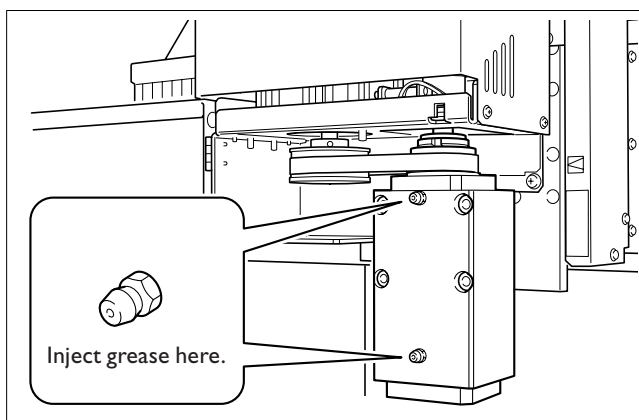

As a general guide, apply grease to the spindle after every 1,000 hours. Inject it using a commercially available grease gun. We recommend using No. 2 lithium grease.

When to Replace the Spindle

Although this may vary according to conditions of use, as a general guide the spindle motor should be replaced after every 8,000 hours and the spindle unit after every 5,000 hours. Early inspection and replacement are recommended.

7-3 What to Do If..

Important Notes on Performing Continuous Cutting for a Prolonged Period

When a Tool Holder Fails to Come Loose

Performing continuous cutting for a prolonged period with a single tool may cause the tool to fail to come loose from the spindle and interrupt cutting. This phenomenon is most likely to happen when the following four conditions all occur.

- When the cutting load is large
- When the end mill is comparatively thick (around 8 mm (0.3 in.) or larger)
- When cutting has been continued for an extended period (around 24 hours or longer)
- When the unit has been allowed to stand with the tool holder remaining gripped for a prolonged period

How to Prevent the Problem

Make sure that the continuous cutting time using a single tool does not exceed 24 hours. Also, never allow the unit to stand with the tool holder remaining gripped for a prolonged period.

How to Correct the Problem If It Occurs

If the tool holder does not come loose, an error occurs and cutting is interrupted. If this happens, follow the procedure below to recover.

1. Shut down the modeling machine.
2. Start the modeling machine and try performing a forced release of the tool.
☞ P. 50, "3-1 Starting and Quitting"
3. If the tool does not come loose, lightly tap the front of the spindle unit using a plastic hammer or wooden mallet.

Verification after Correcting the Problem

After correcting the problem, mount the tool holder in the stocker, then check to make sure the machine has correctly detected the tool holder. Operation is normal if the mounted tool is displayed in VPanel's main window.

The ATC doesn't operate.

Is the cable connected to the modeling machine?

Make sure the cable is connected securely. Also, make the connection while the power to the modeling machine is switched off and VPanel is shut down.

Is the compressed air at the correct pressure?

Check whether the pressure is within the specified values.
☞ P. 45, "2-6 Step 5: Supply Compressed Air"

Tool-change operations fail.

Are the tool holders mounted securely?

When mounting tool holders in stockers, fit them in firmly, as far as they will go. Also check to make sure the locations where they are fitted in are correct.

☞ P. 52, "3-2 Mounting the Tool Holders"

Have you adjusted the tool-change location?

If the adjustment is misaligned, correct tool-change is impossible. Try adjusting again.

☞ P. 46, "2-7 Step 6: Adjust the Tool-change Location"

Is the installation of the magazine unit appropriate?

If the mounted location of the magazine unit is misaligned, correct tool-change is impossible. Check the installed location again.

☞ P. 33, "2-3 Step 2: Attach the Magazine Unit"

The spindle belt is crooked.

Is the spindle unit installed appropriately?

If spindle is not installed perpendicularly because, for example, the flush contact is inadequate, the belt may become crooked or come loose. Check the installation again.

☞ P. 39, "2-4 Step 3: Attach the Spindle and Cylinder"

Responding to an Error Message

This section describes the messages added by installing the unit. For other messages, see the documentation for the modeling machine.

Messages

If a window like this appears on the computer, take action as described below.

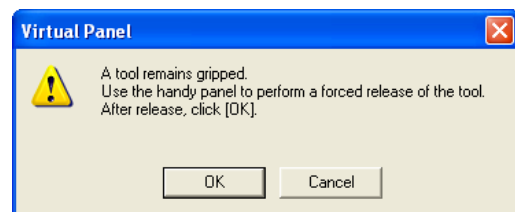

A tool remains gripped.

Startup is not possible when a tool remains gripped. Follow the procedures for performing a forced release of the tool.

☞ P. 50, "3-1 Starting and Quitting"

[Status] Box or Handy Panel Display

If a message appears in the VPanel [Status] box or on the handy panel, take action as described below.

Abnormal ATC air pressure. Paused...

The air pressure has deviated from the permitted value. Adjust the air regulator. Then click [Clear Error], cancel the paused state, and resume cutting.

☞ P. 45, "2-6 Step 5: Supply Compressed Air"

No tool

(Not displayed on the VPanel.)

Automatic measurement of tool length was attempted, but no tools are present in the magazine. Mount tools in the magazine and redo the operation.

☞ P. 59, "4-2 Automatic Measurement of Tool Length"

No tool in stocker No. XXX

During a manual tool-change, an attempt was made to grasp a nonexistent tool. "XXX" is the stocker number. Click [Clear Error], then redo the operation.

No tool in stocker No. XXX. Paused...

During cutting in the RML-1 mode, an attempt was made to grasp a nonexistent tool. "XXX" is the stocker number. Click [Clear Error], then click [Stop Cutting]. Canceling the paused state and resuming cutting instead of quitting is possible, but because unintended operation is highly likely, doing so is not recommended.

No tool in stocker No. XXX. Paused...

(Not displayed on the handy panel.)

During cutting in the NC-code mode, an attempt was made to grasp a nonexistent tool. "XXX" is the stocker number. Click [Clear Error], then click [Stop Cutting]. Canceling the paused state and resuming cutting instead of quitting is possible, but because unintended operation is highly likely, doing so is not recommended.

No tool sensor connected

The sensor cable came loose during detection. Click [Clear Error], then redo detection.

Tool held -- Doing forced release.

(Not displayed on the VPanel.)

Startup is not possible when a tool remains gripped. Follow the procedures for performing a forced release of the tool.

☞ P. 50, "3-1 Starting and Quitting"

Tool in stocker No. XXX. Cannot return.

During a manual tool-change, a different tool was found to be already mounted in the tool-return destination. "XXX" is the stocker number. Click [Clear Error], then remove the offending tool from the magazine.

Tool sensor not found

The tool failed to reach the sensor. Check the amount of tool extension and the detection-start position. Click [Clear Error], then redo detection.

7-4 NC Code Specifications

Items Related to the Mechanical Specifications of the Machine

This section describes the NC codes that are dependent on the machine's mechanical specifications.

☞ "NC Code Reference Manual"

Tool-length offset (G43)

G43 is supported only when this unit is installed. The parameter range is as follows.

Parameter: number

Function: Offset number

Acceptable range: 0 to 4

Effective range: 0 to 4

Tool selection (M06)

M06 is supported only when this unit is installed. The parameter range is as follows.

Parameter: number

Function: Stock number

Acceptable range: 0 to 4

Effective range: 0 to 4

Spindle speed (S)

When this unit is installed, the parameter range for S is as follows.

Parameter: revolution speed

Function: Spindle speed

Acceptable range: -65,535 to 65,535

Effective range: 30 through 12,000 (Specified as rpm)

52 through 82 (Numerical-code specification)

7-5 Unit Specifications

Dimensional Drawings

View When Installed (Standard Table)

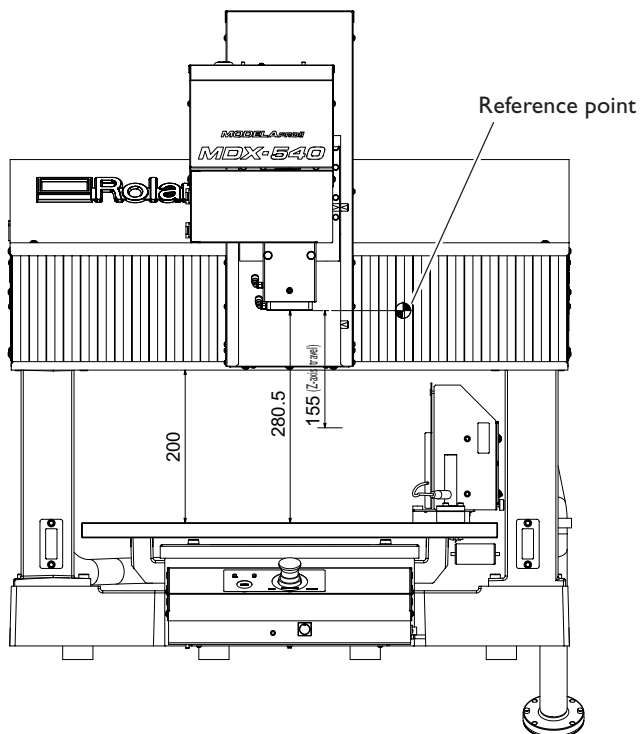
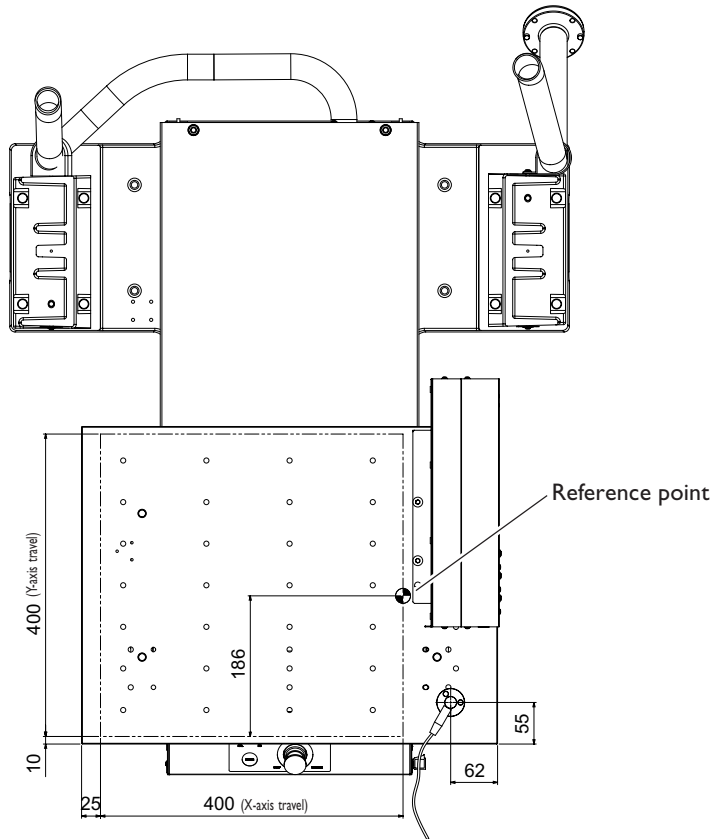

(Unit: mm)

View When Installed (T-slot Table)

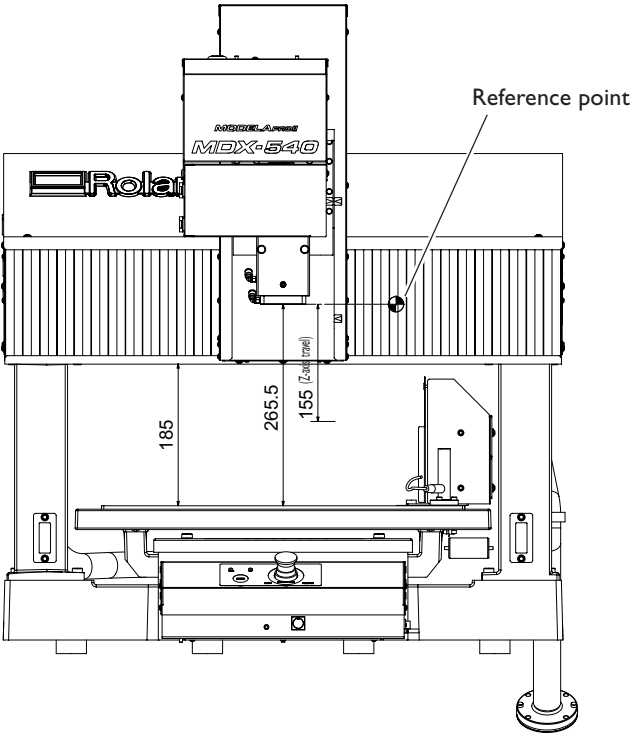
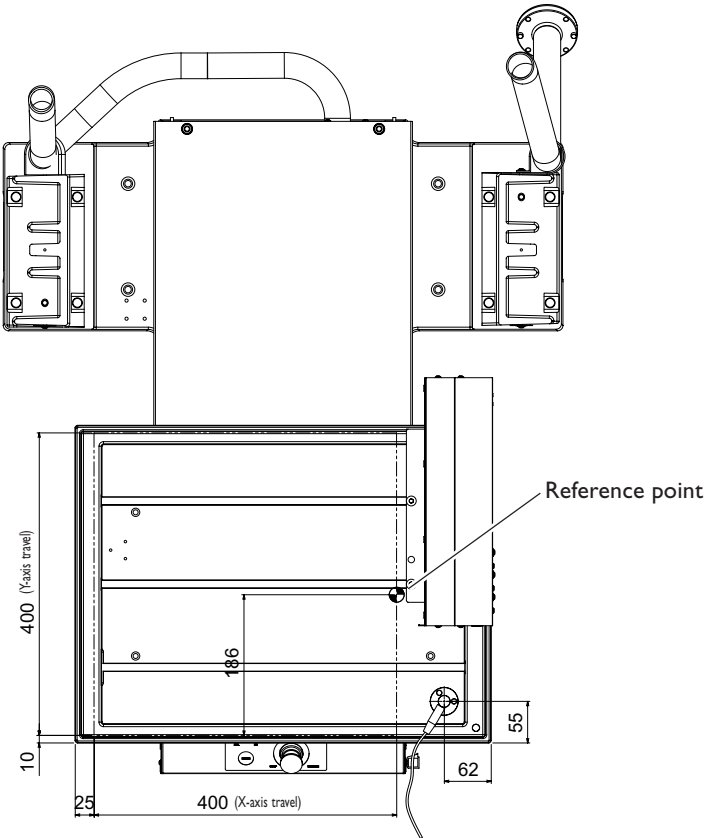

(Unit: mm)

Main Specifications

	ZAT-540
Number of tools housed	4
Maximum tool length	110 mm (4.3 in.)
Maximum tool diameter	10 mm (0.4 in.)
Maximum tool weight	350 g (0.77 lb.)
Tool-holder format	Taper shank: JBS4002 15T 7/24 taper Pull stud: JBS4002 15P (45°), special
Tool-selection method	Direct-changing type, fixed-address specification
Compatible compressed air	0.7 to 1.0 MPa, 50 L/min or higher
Spindle speed	400 to 12,000 rpm; 400 to 3,000 rpm for positioning and centering
Weight	6.8 kg (15 lb.) (total weight including spindle, magazine, control box, etc.)
Included items	Control box, magazine unit, ATC spindle, air cylinder, base plate, Z-origin sensor, spacer, cap screws, hexagonal wrenches, retaining bands, cable retainers, User's Manual

When this unit is installed, the X-axis travels of the MDX-540 are as follows.

- Standard table, no rotary axis unit: 400 mm (15.7 in.)
- Standard table, rotary axis unit present: 270 mm (10.6 in.)/325 mm (12.7 in.) (with expanded X-axis travel)
- T-slot table, no rotary axis unit: 400 mm (15.7 in.)
- T-slot table, rotary axis unit present: 203 mm (7.9 in.)/258 mm (10.1 in.) (with expanded X-axis travel)



100001888

R1-060602