

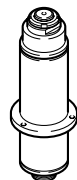
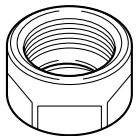
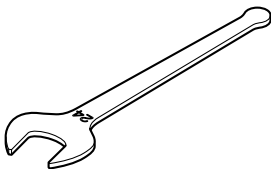
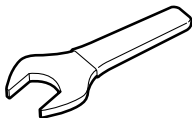

This is a spindle unit for the MODELA Pro II MDX-540.

Included Items

 Spindle Unit	 Nut x 1	 wrench (24 mm) x 1	 Nut wrench x 1
 Hexagonal wrench (3 mm) x 1	 Cap screws (M4 x 15 mm) x 3		

Collet Chuck Specifications

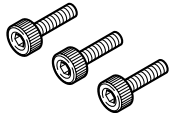
With the ZS-540TY, use the following collet chucks and nuts.

Collet chuck

- > Yukiwa Seiko EY16
- > LEGO-FIX ER16
- > SCHAUBLIN ESX16

Nut

- > Yukiwa Seiko NY16H22
- > LEGO-FIX Hi-Q/ER16 (UM/ER16)
- > SCHAUBLIN EX16

Yukiwa Seiko EY16 Collet

Model number	Compatible shank (mm)	Model number	Compatible shank (mm)
EY16 - 1	1.0 to 0.5	EY16 - 5	5.0 to 4.0
EY16 - 1.5	1.5 to 1.0	EY16 - 6	6.0 to 5.0
EY16 - 2	2.0 to 1.5	EY16 - 7	7.0 to 6.0
EY16 - 2.5	2.5 to 2.0	EY16 - 8	8.0 to 7.0
EY16 - 3	3.0 to 2.5	EY16 - 9	9.0 to 8.0
EY16 - 3.5	3.5 to 3.0	EY16 - 10	10.0 to 9.0
EY16 - 4	4.0 to 3.5		

Installation Procedure

CAUTION Be sure to perform installation or replacement with the power cord disconnected. Failure to do so may lead to danger of entanglement in the machine resulting in injury.

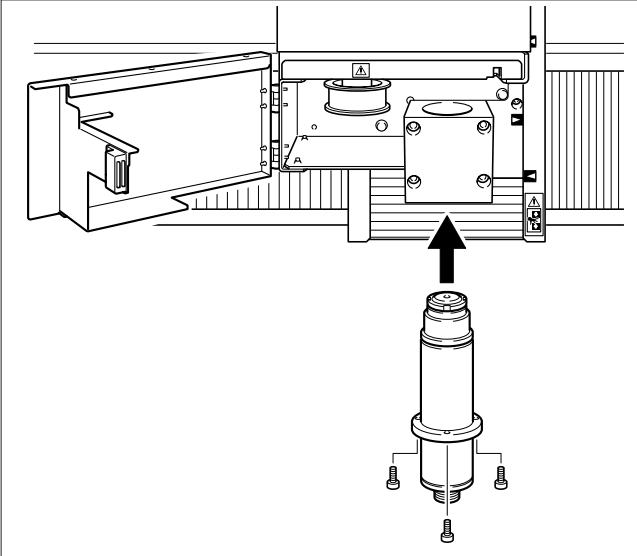
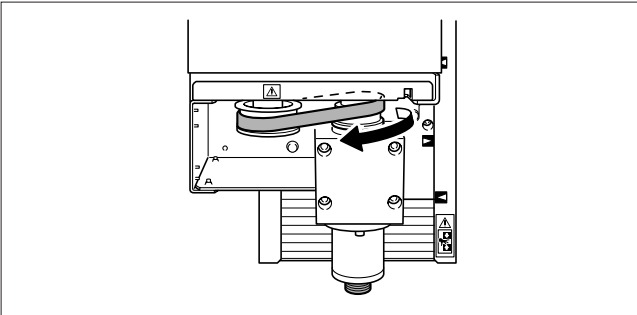
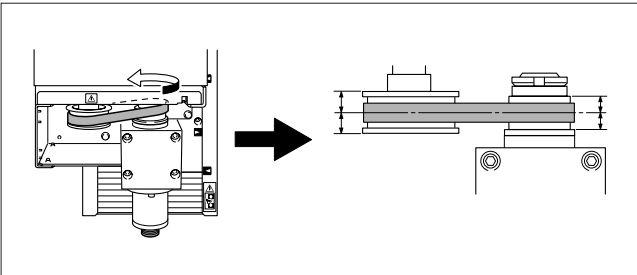
- 1  Mount the spindle unit.
- 2  Engage the belt onto the pulley. The belt is included with the cutting machine. (Alternatively, use the one you removed during replacement.) The inner side is slick.
- 3  While turning the pulley to break in the belt, keep the belt at the correct position.

Replacement

Follow the procedure described above in reverse to remove the old spindle unit, then install the new one.