

Automatic Media Take-up Unit

**TUC-2 &**  
**TU2-74**  
**TU2-64**  
**TU2-54**  
**TU2-30**

# User's Manual

---

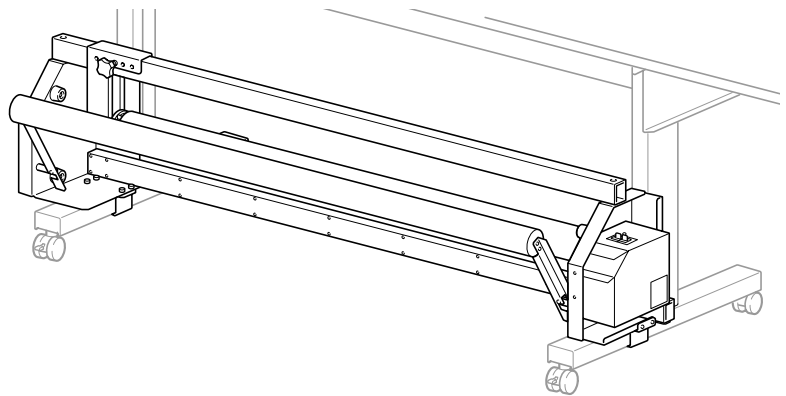

**TUC-2**  
**TAKE-UP CONTROLLER**

SIGN MAKER ACCESSORY  
PLOTTER DA TAGLIO ACCESSRIO  
ACCESSOIRE POUR TRACEUR DE DECOUPE  
SCHNEIDPLOTTER-ZUBEHÖRTEIL  
ACCESORIO PARA MÁQUINA PARA ROTULACION

Thank you very much for purchasing this product.

- To ensure correct and safe usage with a full understanding of this product's performance, please be sure to read through this manual completely and store it in a safe location.
- Unauthorized copying or transferral, in whole or in part, of this manual is prohibited.
- The contents of this operation manual and the specifications of this product are subject to change without notice.
- The operation manual and the product have been prepared and tested as much as possible. If you find any misprint or error, please inform us.
- Roland DG Corp. assumes no responsibility for any direct or indirect loss or damage which may occur through use of this product, regardless of any failure to perform on the part of this product.
- Roland DG Corp. assumes no responsibility for any direct or indirect loss or damage which may occur with respect to any article made using this product.

**For the USA**

**FEDERAL COMMUNICATIONS COMMISSION  
RADIO FREQUENCY INTERFERENCE  
STATEMENT**

This equipment has been tested and found to comply with the limits for a Class A digital device, pursuant to Part 15 of the FCC Rules.

These limits are designed to provide reasonable protection against harmful interference when the equipment is operated in a commercial environment.

This equipment generates, uses, and can radiate radio frequency energy and, if not installed and used in accordance with the instruction manual, may cause harmful interference to radio communications.

Operation of this equipment in a residential area is likely to cause harmful interference in which case the user will be required to correct the interference at his own expense.

Unauthorized changes or modification to this system can void the users authority to operate this equipment.

**For Canada**

**CLASS A NOTICE**

This Class A digital apparatus meets all requirements of the Canadian Interference-Causing Equipment Regulations.

**CLASSE A AVIS**

Cet appareil numérique de la classe A respecte toutes les exigences du Règlement sur le matériel brouilleur du Canada.



**ROLAND DG CORPORATION**

**1-6-4 Shinmiyakoda, Hamamatsu-shi, Shizuoka-ken, JAPAN 431-2103**

**MODEL NAME** : See the MODEL given on the rating plate.

**RELEVANT DIRECTIVE** : **EC LOW VOLTAGE DIRECTIVE (73/23/EEC)**

**EC ELECTROMAGNETIC COMPATIBILITY DIRECTIVE (89/336/EEC)**

**WARNING**

This is a Class A product. In a domestic environment this product may cause radio interference in which case the user may be required to take adequate measures.

# Contents

 To Ensure Safe Use .....	2
Important Notes on Handling and Use .....	6
User's Manual .....	7
1. Getting Started .....	8
System Features .....	8
Main Compatible Models (As of March 2007) .....	8
Changes in Printer Functioning .....	8
Part Names and Functions .....	9
2. Checking the Included Items .....	10
3. Assembling and Installing .....	12
Read This First .....	12
Assembling and Installing .....	12
4. Operation .....	20
Operating Conditions for the Take-up Unit .....	20
How to Load Media .....	21
To Take up Media Manually .....	27
How to Remove Taken-up Media .....	28
5. What to do if... ..	29
The take-up unit doesn't take up media. ....	29
Media take-up is not straight. ....	29
6. Appendix .....	30
Locations of the Power Rating and Serial Number Labels .....	30
Specifications .....	30



Company names and product names are trademarks or registered trademarks of their respective holders.





# To Ensure Safe Use

Improper handling or operation of this machine may result in injury or damage to property. Points which must be observed to prevent such injury or damage are described as follows.

## About WARNING and CAUTION Notices

 <b>WARNING</b>	Used for instructions intended to alert the user to the risk of death or severe injury should the unit be used improperly.
 <b>CAUTION</b>	Used for instructions intended to alert the user to the risk of injury or material damage should the unit be used improperly. * Material damage refers to damage or other adverse effects caused with respect to the home and all its furnishings, as well to domestic animals or pets.

## About the Symbols

	The  symbol alerts the user to important instructions or warnings. The specific meaning of the symbol is determined by the design contained within the triangle. The symbol at left means "danger of electrocution."
	The  symbol alerts the user to items that must never be carried out (are forbidden). The specific thing that must not be done is indicated by the design contained within the circle. The symbol at left means the unit must never be disassembled.
	The  symbol alerts the user to things that must be carried out. The specific thing that must be done is indicated by the design contained within the circle. The symbol at left means the power-cord plug must be unplugged from the outlet.

 **Media weighs 30 kg (66 lb.)**

### **WARNING**



Handling roll media is an operation that must be performed by two persons or more, and care must be taken to prevent falls.

Attempting to lift heavy media in a manner that taxes your strength may cause physical injury.

### **WARNING**



When storing roll media, implement adequate safety measures to ensure that the stored media will not roll, fall, or topple over.

Danger exists of becoming pinned under the media and suffering serious injury.

 **Incorrect operation may cause injury.**

 **WARNING**

 **Be sure to follow the operation procedures described in this documentation. Never allow anyone unfamiliar with the usage or handling of the machine to touch it.**

Incorrect usage or handling may lead to an accident.

 **Keep children away from the machine.**  
The machine includes areas and components that pose a hazard to children and may result in injury, blindness, choking, or other serious accident.

 **Never operate the machine while tired or after ingesting alcohol or any medication.**  
Operation requires unimpaired judgment. Impaired judgment may result in an accident.

 **Never use the machine for any purpose for which it is not intended, or use the machine in an undue manner that exceeds its capacity.**  
Doing so may result in injury or fire.

 **For accessories (optional and consumable items, AC adapter, power cord, and the like), use only genuine articles compatible with this machine.**  
Incompatible items may lead to an accident.

 **Before attempting cleaning, maintenance, or attachment or detachment of optional items, disconnect the power cord.**  
Attempting such operations while the machine is connected to a power source may result in injury or electrical shock.

 **Never attempt to disassemble, repair, or modify the machine.**  
Doing so may result in fire, electrical shock, or injury. Entrust repairs to a trained service technician.

 **CAUTION**

 **Exercise caution to avoid being pinched or becoming caught.**  
Inadvertent contact with certain areas may cause the hand or fingers to be pinched or become caught. Use care when performing operations.

 **Never attempt operation while wearing a necktie, necklace, or loose clothing. Bind long hair securely.**  
Such items may become caught in the machine, resulting in injury.

 **Conduct operations in a clean, brightly lit location.**  
Working in a location that is dark or cluttered may lead to an accident, such as becoming caught in the machine as the result of an inadvertent stumble.

 **Never climb or lean on the machine.**  
The machine is not made to support a person. Climbing or leaning on the machine may dislodge components and cause a slip or fall, resulting in injury.

**⚠ Danger of electrical short, shock, electrocution, or fire**

**⚠ WARNING**

**!** Connect to an electrical outlet that complies with this machine's ratings (for voltage, frequency, and current). Incorrect voltage or insufficient current may cause fire or electrical shock.

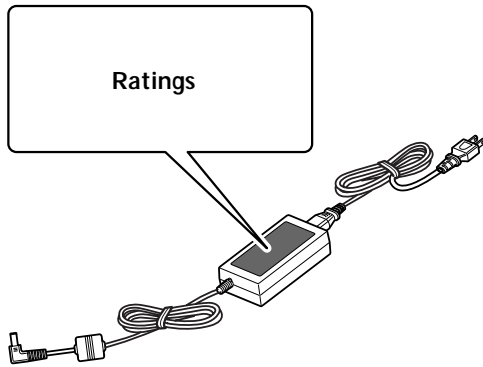

**⊘** Never use out of doors or in any location where exposure to water or high humidity may occur. Never touch with wet hands. Doing so may result in fire or electrical shock.

**⊘** Never allow any foreign object to get inside. Never expose to liquid spills. Inserting objects such as coins or matches or allowing beverages to be spilled into the ventilation ports may result in fire or electrical shock. If anything gets inside, immediately disconnect the power cord and contact your authorized Roland DG Corp. dealer.

**⊘** Never place any flammable object nearby. Never use a combustible aerosol spray nearby. Never use in any location where gases can accumulate. Combustion or explosion may be a danger.

**⚠ WARNING**

**!** Handle the power cord, plug, and electrical outlet correctly and with care. Never use any article that is damaged. Using a damaged article may result in fire or electrical shock.

**!** When using an extension cord or power strip, use one that adequately satisfies the machine's ratings (for voltage, frequency, and current). Use of multiple electrical loads on a single electrical outlet or of a lengthy extension cord may cause fire.

**!** Position so that the power plug is within immediate reach at all times. This is to enable quick disconnection of the power plug in the event of an emergency. Install the machine next to an electrical outlet. Also, provide enough empty space to allow immediate access to the electrical outlet.

**!** If sparking, smoke, burning odor, unusual sound, or abnormal operation occurs, immediately unplug the power cord. Never use if any component is damaged. Continuing to use the machine may result in fire, electrical shock, or injury. Contact your authorized Roland DG Corp. dealer.

**⚠ Important notes about the power cord, plug, and electrical outlet**

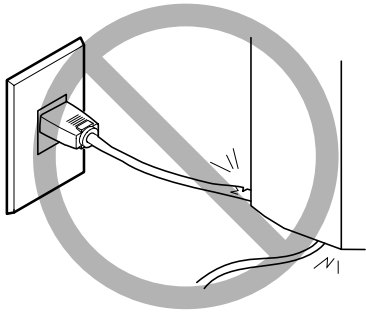

**Never place any object on top or subject to damage.**

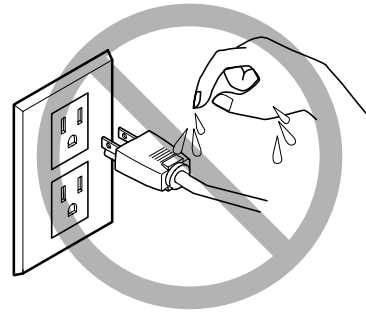

**Never allow to get wet.**

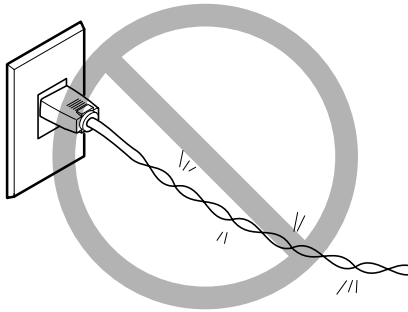

**Never bend or twist with undue force.**

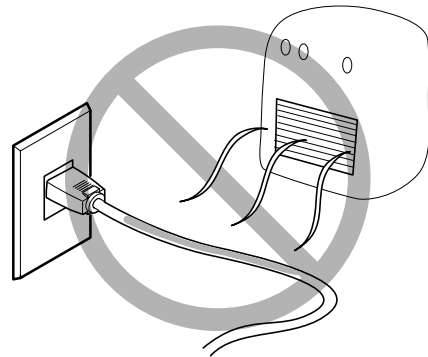

**Never make hot.**

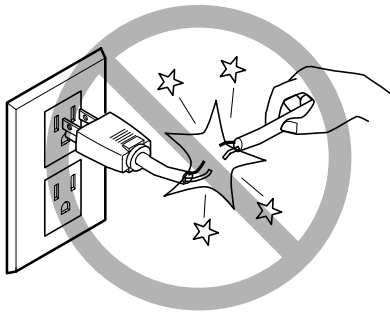

**Never pull with undue force.**

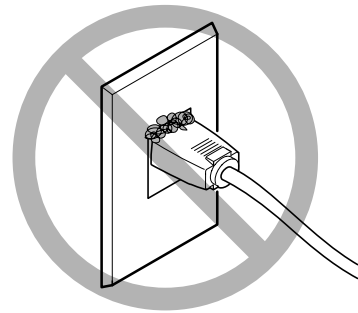

**Dust may cause fire.**

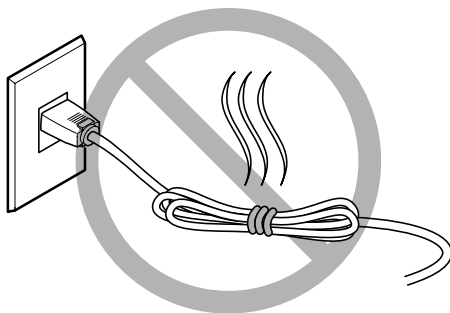

**Never bundle, bind, or roll up.**

# Important Notes on Handling and Use

---

This machine is a precision device. To ensure the full performance of this machine, be sure to observe the following important points. Failure to observe these may not only result in loss of performance, but may also cause malfunction or breakdown.

## This Machine Is a Precision Device

- > Handle carefully, and never subject the machine to impact or excessive force.
- > Never cover the ventilation holes with cloth, tape, or anything else.



# ***User's Manual***

---

# 1. Getting Started

## System Features

- This is a take-up unit for large-format printers from Roland DG Corp.
- This unit automatically takes up media as it is being printed. This enables lengthy output and unattended operation at night to be accomplished efficiently.
- Media weighing up to 30 kilograms can be used. Stable take-up is possible even for heavy media. (If the printer's usable media weight is less than 30 kilograms, media weighing more than this cannot be used.)

## Main Compatible Models (As of March 2007)

- PRO II/PRO IIV series (including SOLJET PRO IIV series, SOLJET PRO II series, Hi-Fi JET PRO II series, CAMM JET PRO II series)
- VersaCAMM series (including VP series, SP series)

## Changes in Printer Functioning

Installing this unit changes the printer's menus and other behavior in the following ways

### VP-540/300

- At the [SETUP SHEET] screen, selecting either [ROLL] or [TU] is now possible. When performing printing using this unit, select [TU].

## Part Names and Functions

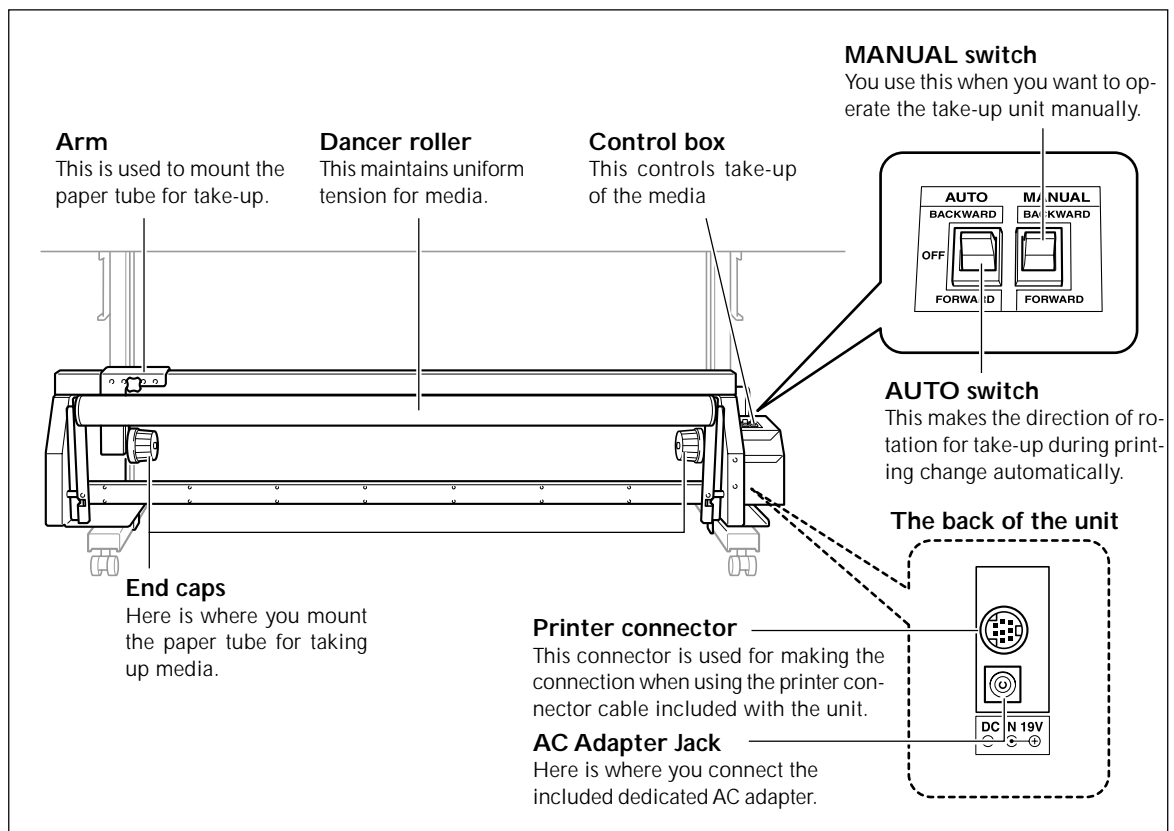

### About the Notation Used in This Manual

This document uses the following images to indicate the keys and lights on the printer's operation panel.

Cursor keys

SETUP key/light

ENTER key

BASE POINT key

## 2. Checking the Included Items

The following included items are contained in two packing cartons. Make sure they are all present and accounted for.

---

### Control Box (TUC-2)

---

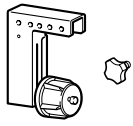

Arm/Arm retaining screw

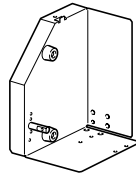

Frame

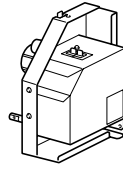

Control box

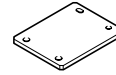

Mounting fixture A

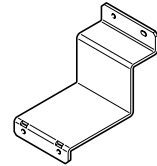

Mounting fixture B

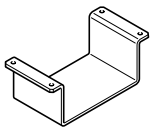

Mounting fixture C

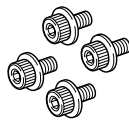

Bolts with washers



Small Bolts

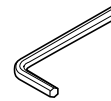

Hex wrench (small)

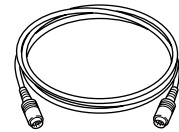

Printer connector cable

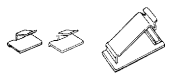

Small Large

Cable clamps

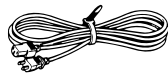

Power Cord



AC adapter

---

**Rail and accessories (TU2-74/64/54/30)**

---

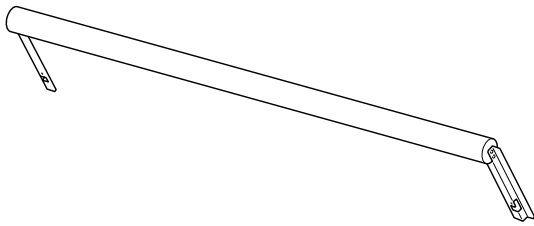

Dancer roller

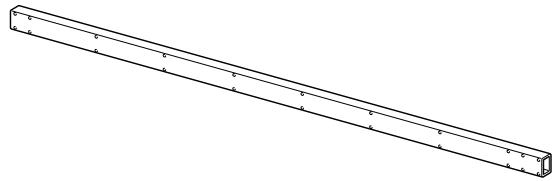

Support bar

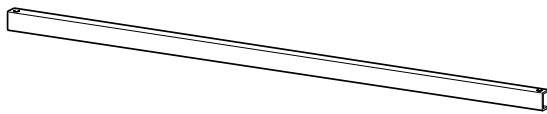

Rail slider

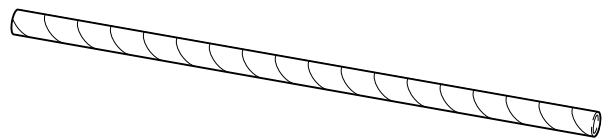

Paper tube

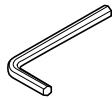

Hex wrench (large)



Large bolts

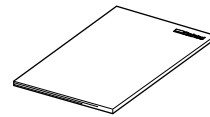

User's manual (this document)

# 3. Assembling and Installing

## Read This First

- Before attempting the operations described here, first install the printer you're using at the target location.
- Carry out the operations in a location that is flat, level, and stable.
- We recommend carrying out the operations at a location near to where the printer you're using is installed.

## Assembling and Installing

**⚠ CAUTION** Unpacking and installation must be carried out by two or more persons. Otherwise the machine or the stand may fall, resulting in injury.

### 1. Assemble the take-up unit.

① Attach the frame and control box to the support bar.

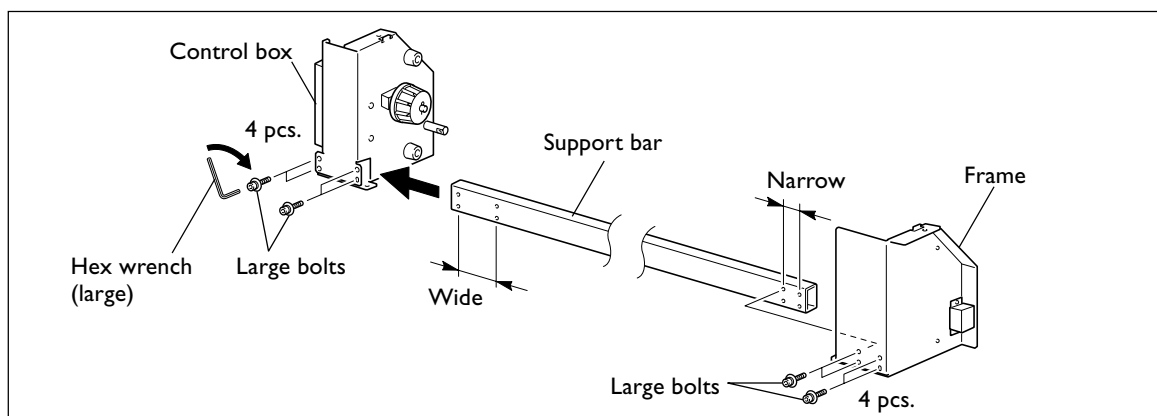

② Attach the arm to the rail slider and secure in place with the arm retaining screw.

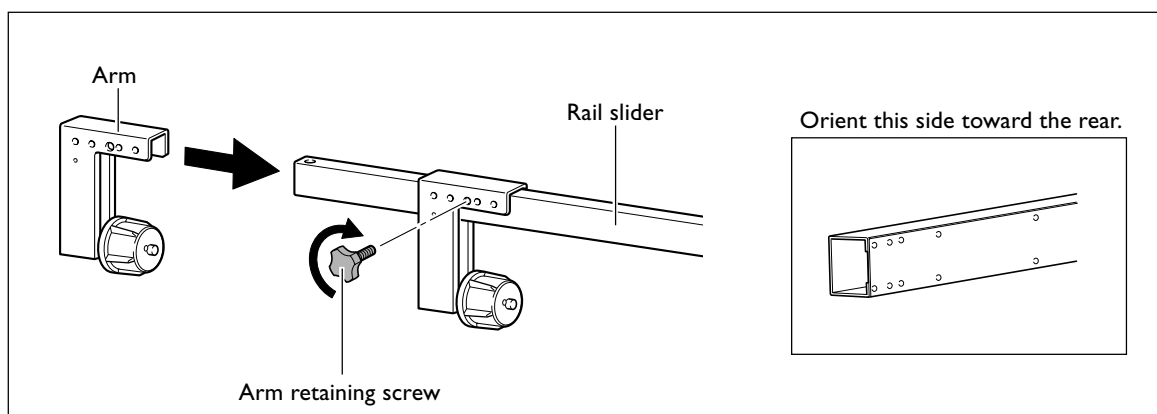

**3** Place the rail slider on the control box and the frame and secure it in place.

Line up the tab on the frame with the slot in the rail slider, then use large bolts to secure it in place first to the control box, and then to the frame.

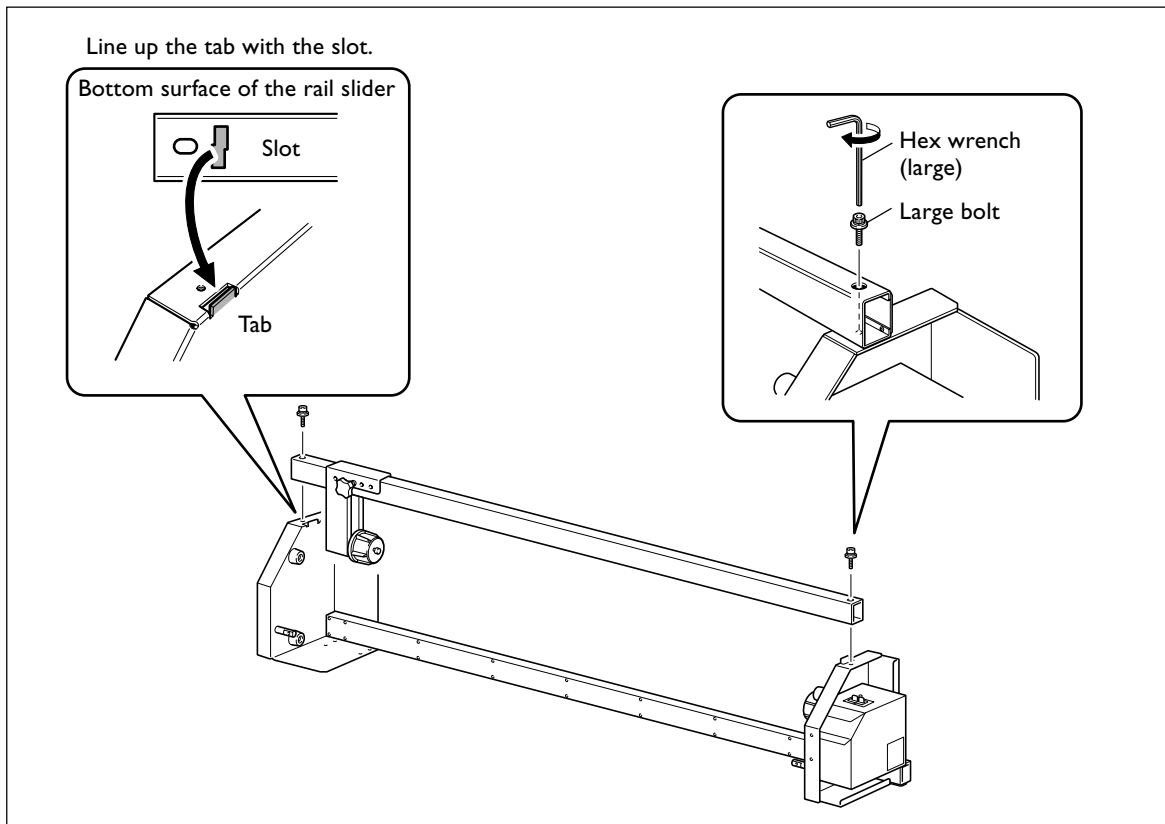

**4** Lay the unit on its side oriented as shown in the figure, then use large bolts to fasten the control box and the frame to the support bar.

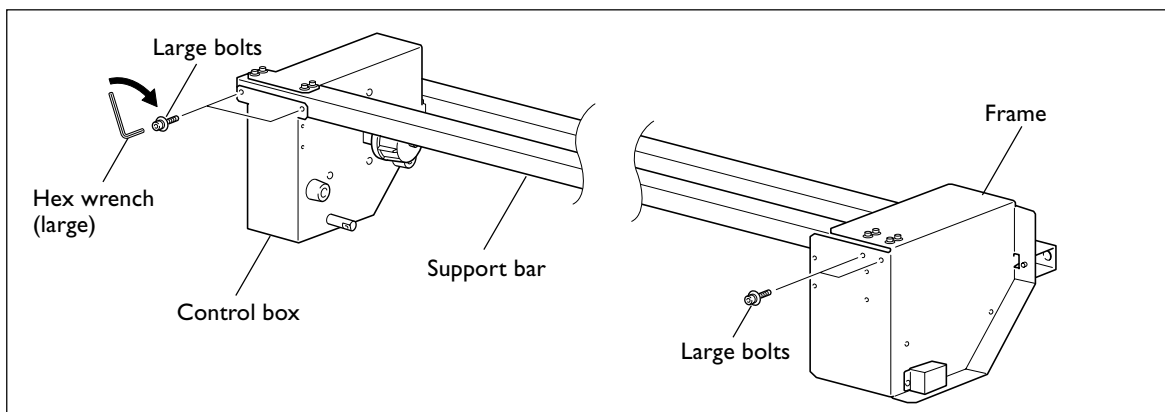

## 2. Secure the assembled take-up unit in place on the printer stand.

- 1 Check to make sure the screws on the printer stand are not loose.  
Retighten if loose.

- 2 Place the take-up unit on the stand.

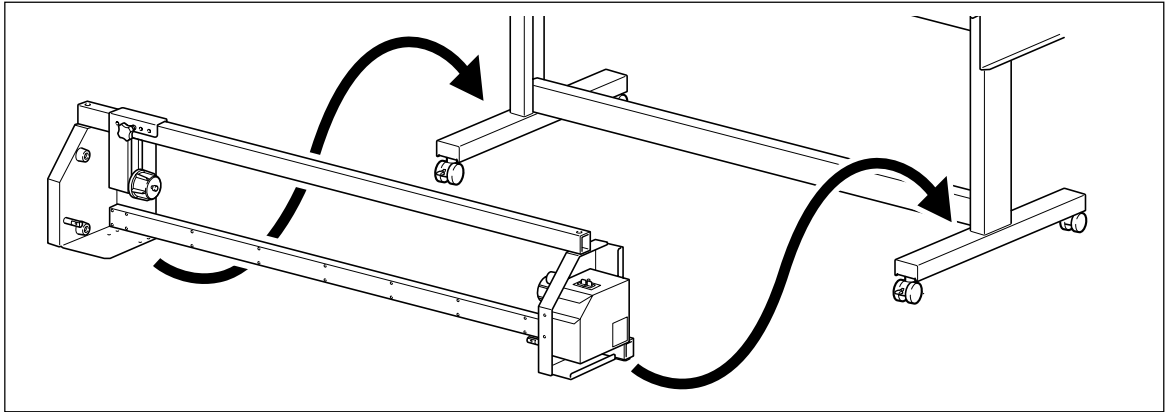

- 3 Determine where to secure the take-up unit in place.

- 1 Secure mounting fixture A in place using bolts with washers.

The mounting location varies according to the printer.

- 2 Make sure the take-up unit is completely flush with the stand.

Place so that the control box and frame are pressed against the stand leg and mounting fixture A is pressed against the caster.

PRO II/PRO IIV series, SP-540V

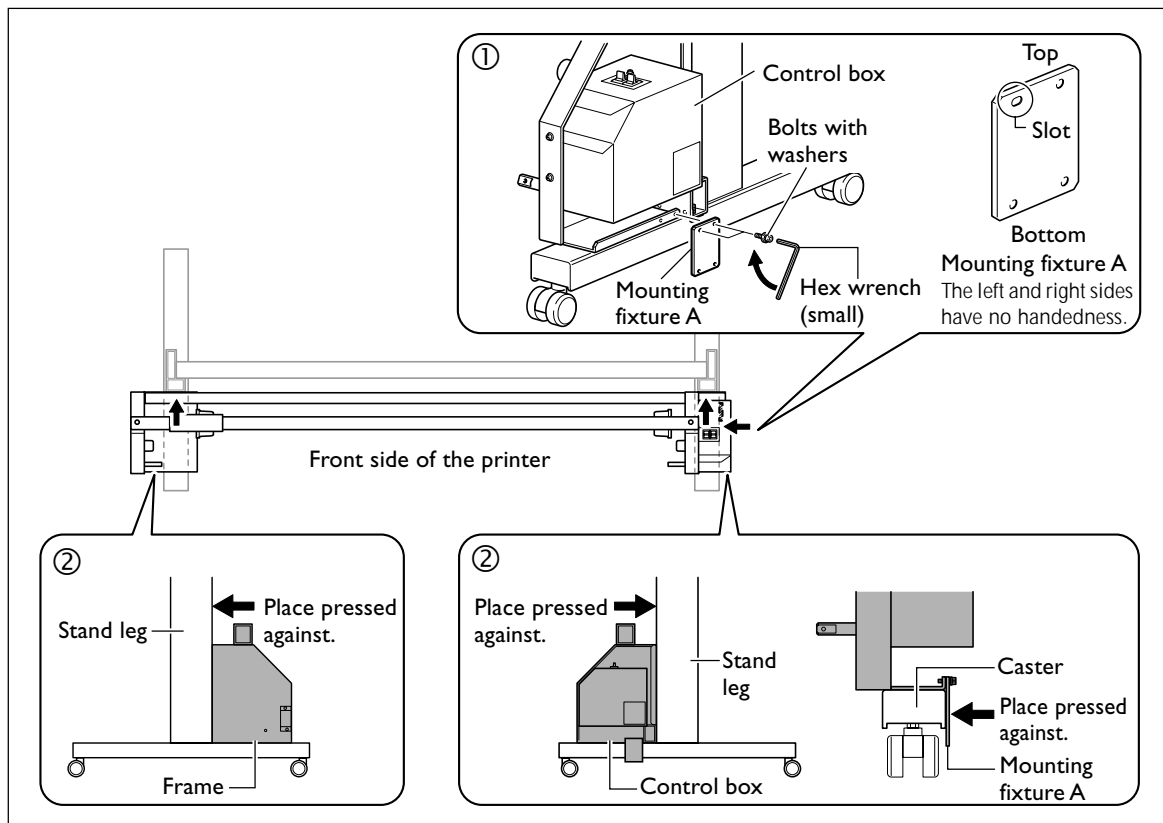



Other Models (VP series, SP-300V/300 etc.)

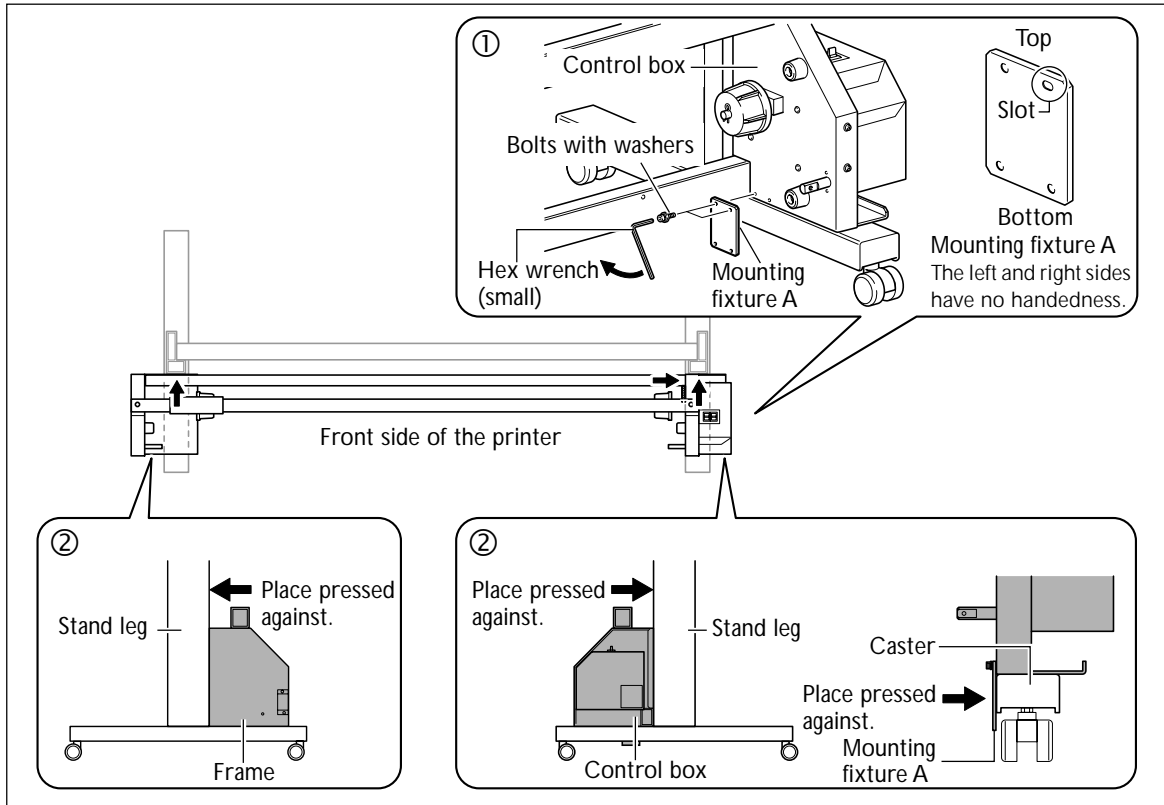

- ④ Attach mounting fixtures B and C and secure the take-up unit to the stand.  
Tighten the screws while holding the take-up unit pressed against the stand leg.

PRO II/PRO IIV series, SP-540V

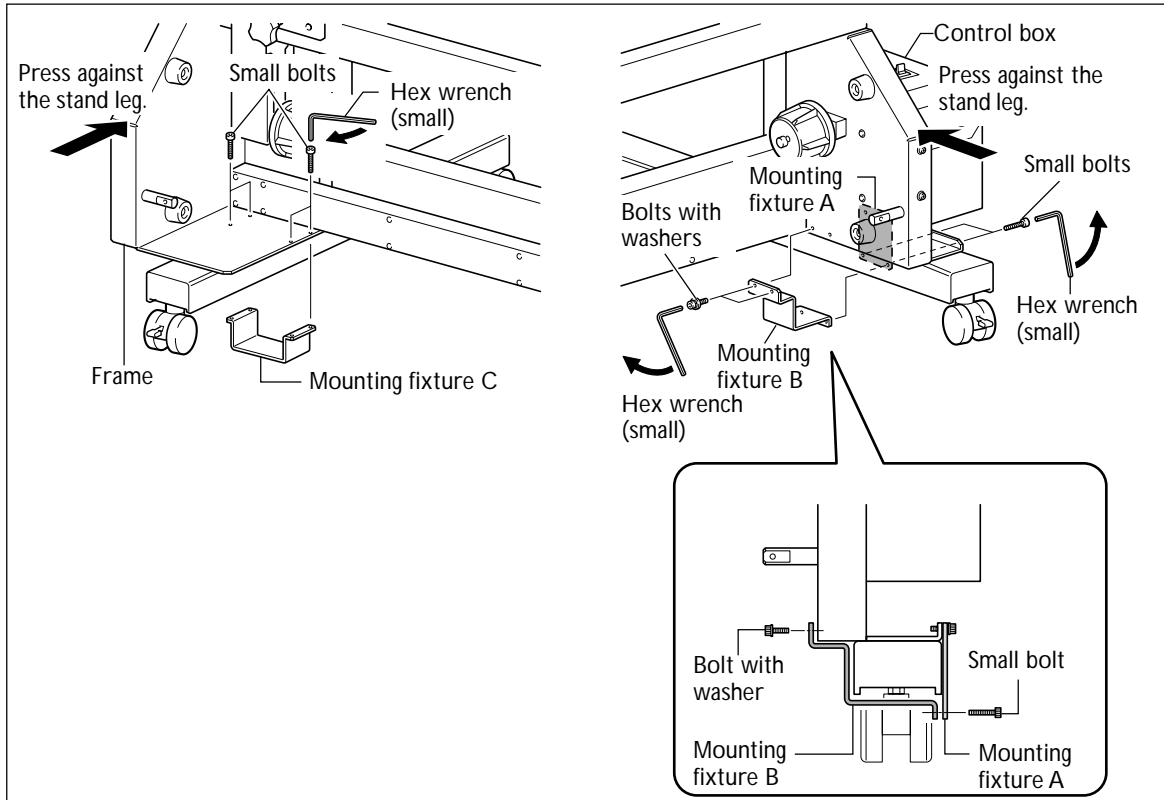

### 3. Assembling and Installing

Other Models (VP series, SP-300V/300 etc.)

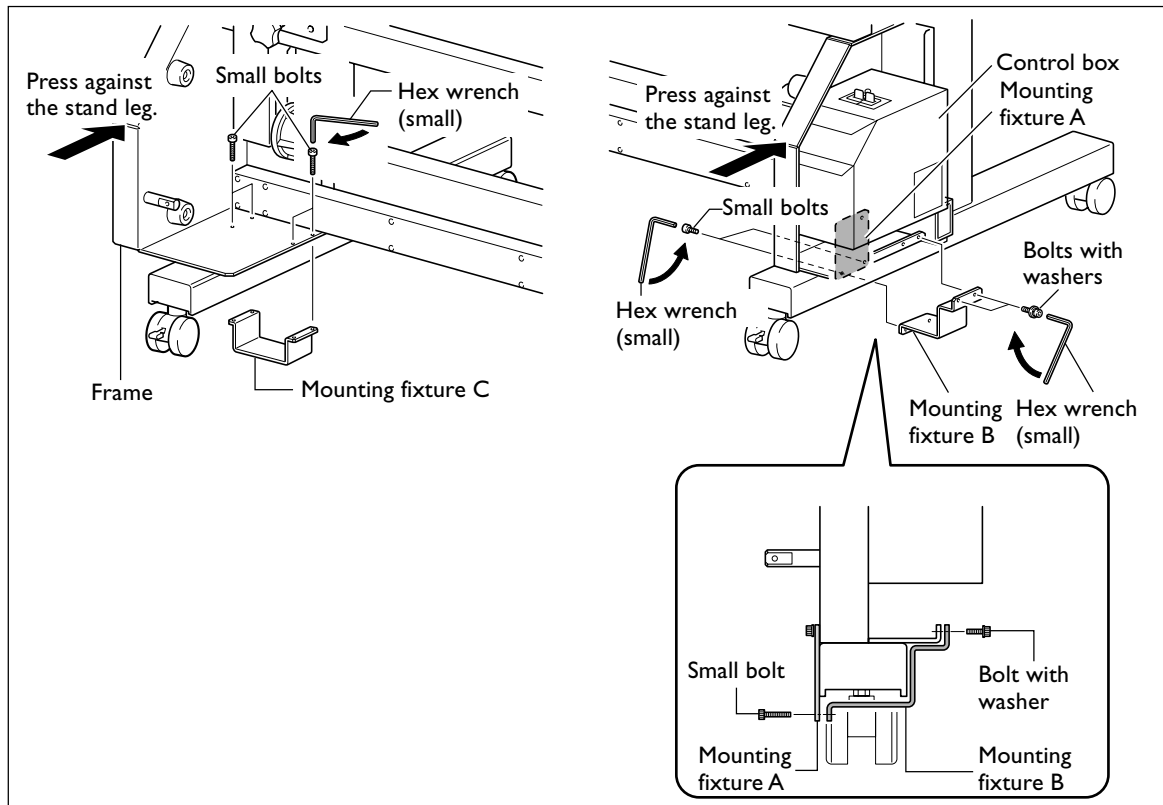

After securing in place, hold the unit at the locations shown in the figure, apply gentle pressure, and make sure the assembly is free of looseness. If looseness is present, again press the take-up unit against the stand leg and caster and tighten the small bolts.

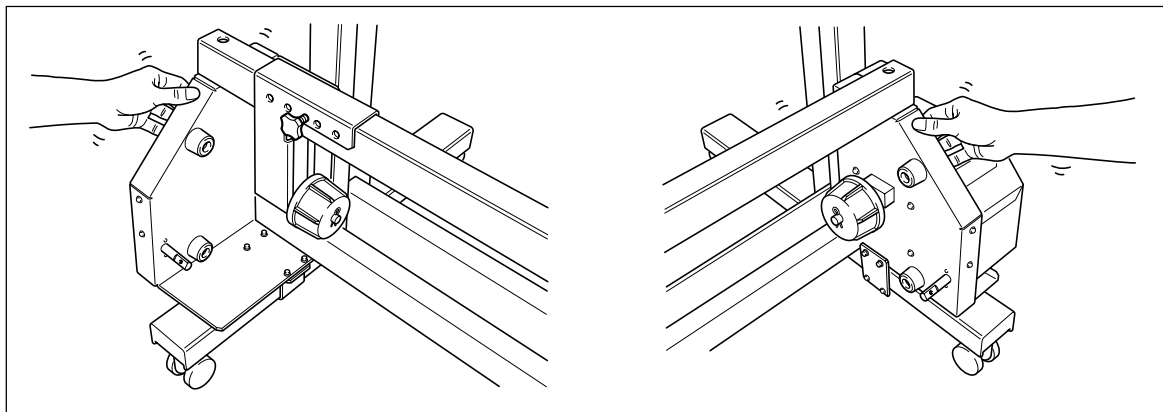

### 3. Attach the dancer roller and mount the paper tube.

**1** Attach the dancer roller.

Working from the right side first, secure in place.

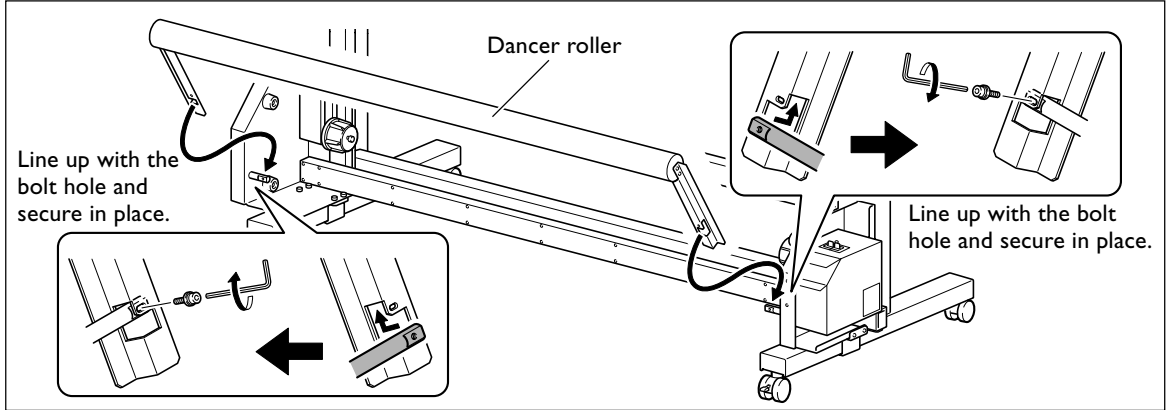

**2** Pull the dancer roller back toward you.

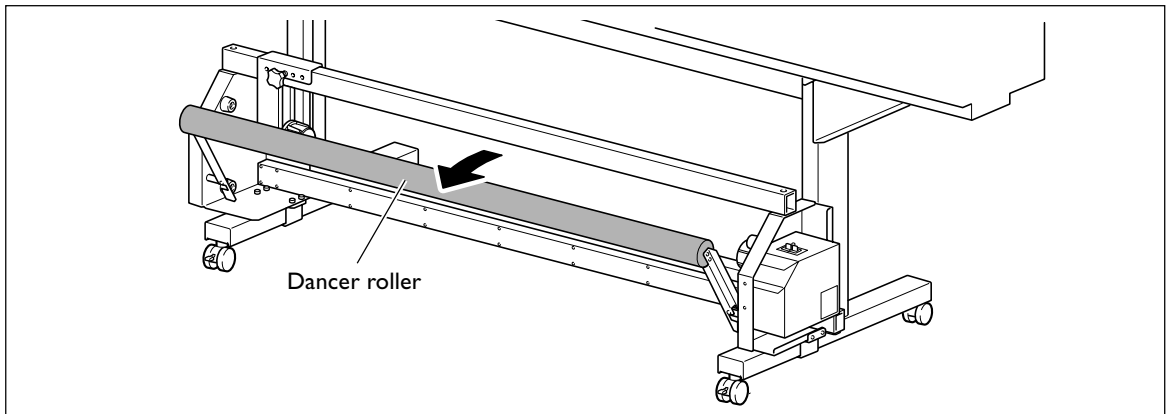

**3** Loosen the arm adjustment screw.

Loosen the screw just enough to allow the arm to move left and right.

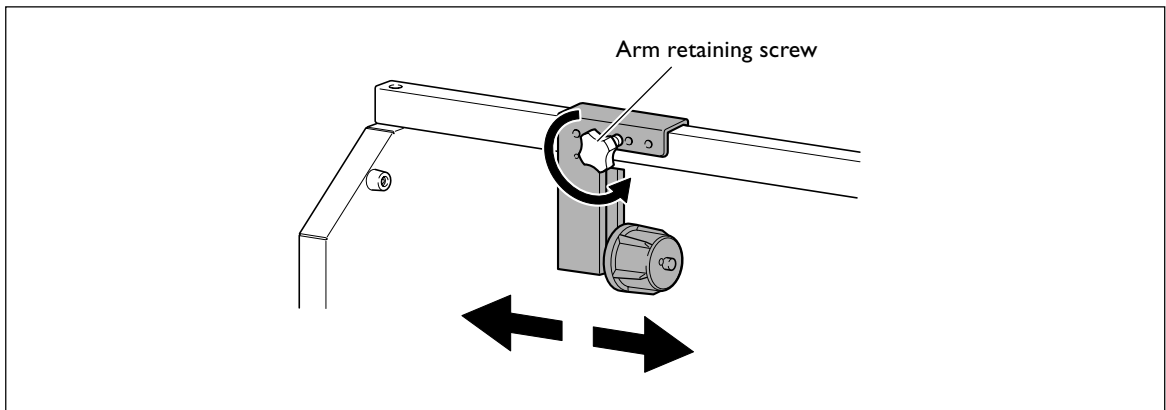

### 3. Assembling and Installing

**4 Attach the end caps to the paper tube and secure the arm in place.**

Position the arm to match the length of the paper tube, then secure it in place by tightening the arm adjustment screw.

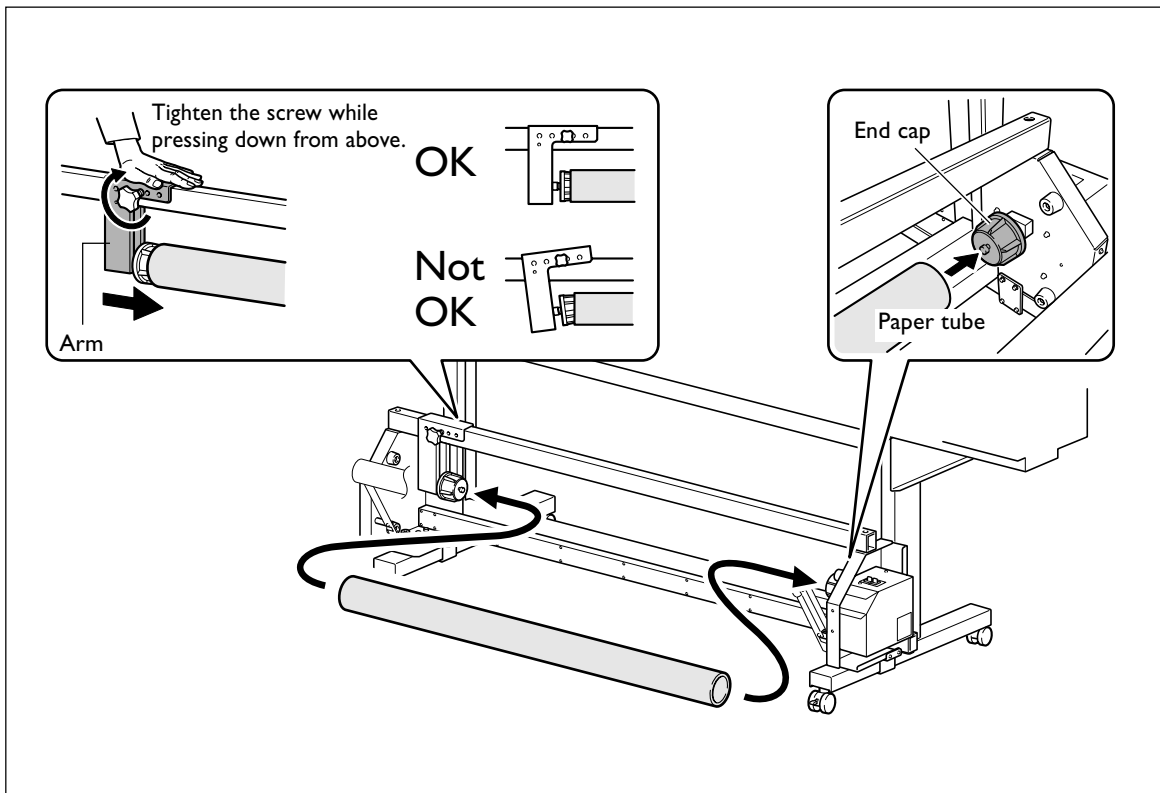

## 4. Connect the cables.

**⚠ WARNING** Connect to electrical outlet that complies with this machine's ratings (for voltage, frequency, and current).  
Incorrect voltage or insufficient current may cause fire or electrical shock.

- 1 Insert the printer connector cable into the printer connector and connect the other end to the printer.  
Affix large and small cable clamps at the locations shown in the figure and secure the cables in place. Bundle excess cable into the large cable clamp.  
If you're using a PRO II/PRO II V series or SP series printer, this cable connection is not necessary.
- 2 Place the AC adaptor at the location shown in the figure and connect it to the AC adaptor jack.
- 3 Connect the power cord.  
Affix a small cable clamp at the location shown in the figure and secure the power cord in place.

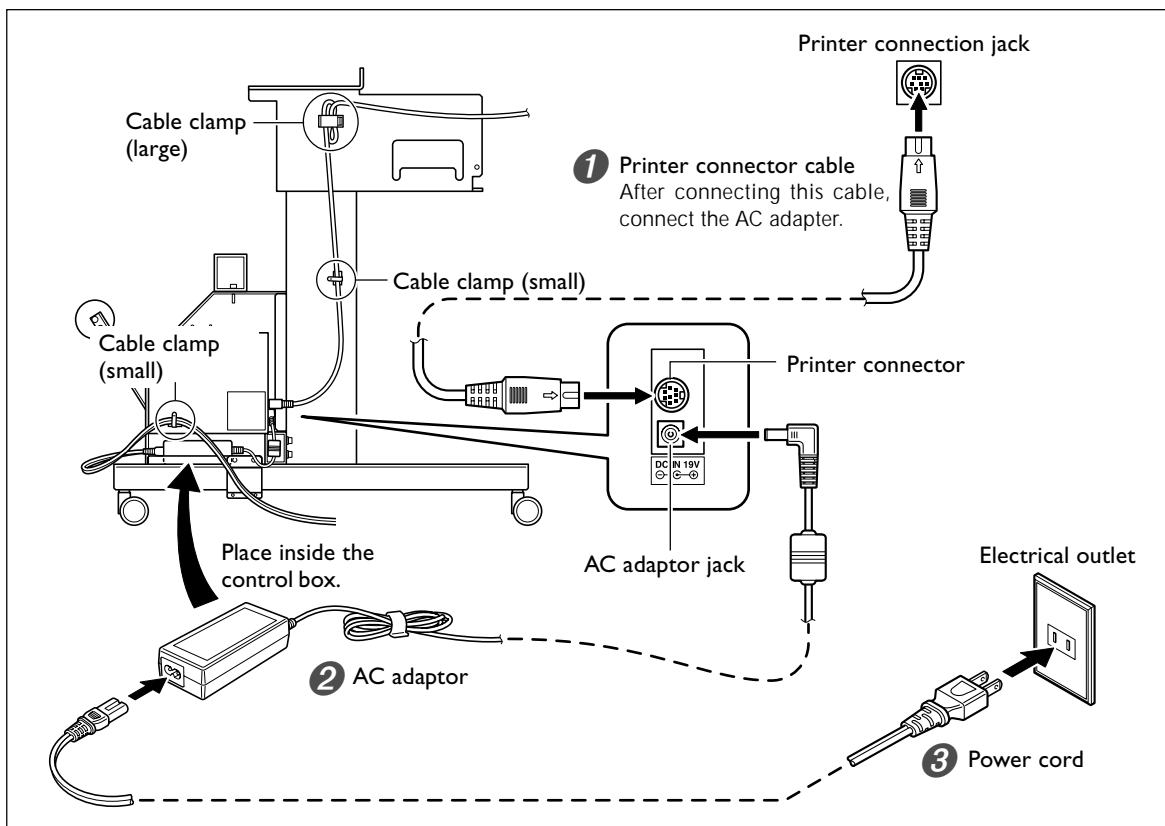

# 4. Operation

## Operating Conditions for the Take-up Unit

### *Never pull the media with excessive force.*

---

Pulling the media with excessive force may actuate the protective feature and result in an error. To avoid pulling the media with excessive force, be sure to observe the following points.

- Never operate the MANUAL switch for the take-up unit when the loading lever is engaged (lowered).
- Never use the cursor key (  ) to feed the media in reverse.

If the printer is provided with a cutting feature, be sure to observe the following points as well. These are all intended to avoid pulling the media with excessive force.

- Never perform cutting operations.
- When feeding out media toward the front of the machine by pressing the cursor key (  ), be sure to set the base point.
- Set the [PREFEED] setting-menu item to "DISABLE."
- If a [FEED FOR DRY] menu item is available, set it to "DISABLE."

### *Never use the automatic-cutoff feature for media.*

---

When the setting to execute automatic cutoff of the media is made on the computer, media cutoff is performed when printing of one page finishes. When you're performing continuous printing and take-up for two or more pages, turn off the automatic-cutoff feature on the computer. Take-up quits as soon as the media is cut off.

## How to Load Media

- ⚠ CAUTION** Load roll media correctly. Otherwise the media may fall and cause injury.
- ⚠ CAUTION** Roll media weighs about 30 kg (66 lb.). To avoid injury, handle with care.
- ⚠ CAUTION** Never load media that weighs more than 30 kg (66 lb.). The printer may fail to withstand the weight and topple over, or the media may fall from the unit.

### VP series

## 1. Pass the media through the printer.

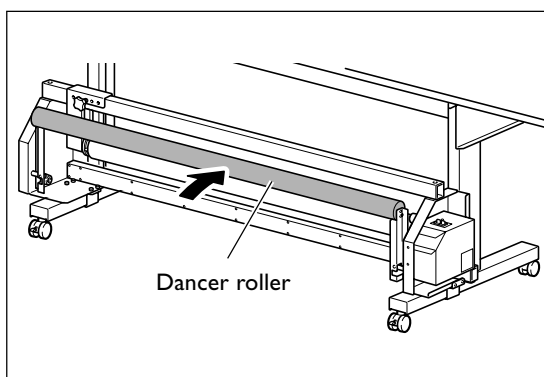

①



Move the dancer roller toward the rear.

②



Switch on the printer's sub power, and when the screen shown in the figure appears, use   to select [TU].

③

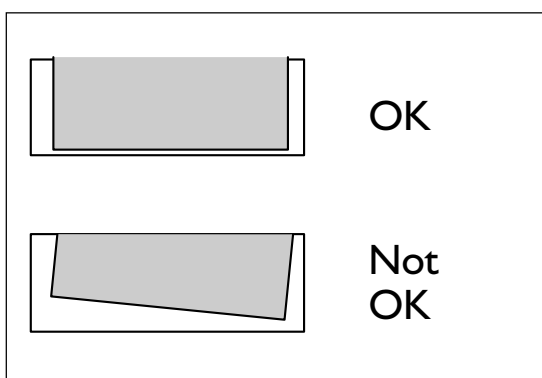

Load roll media onto the printer, then lower the loading lever.

For information on how to perform loading, refer to the user's manual for the printer.



After loading, check the following points.

- The media is loaded straight.
- All areas of the media are taut.

If the media is slack or crooked, raise the loading lever and reload the media.

- ④ Make sure the printer's [PREFEED] and [FEED FOR DRY] menu items are each set to "DISABLE."  
For information on how to check or change setting values, refer to the user's manual for the printer.

## 2. Fasten the media to the paper tube.

- ① Make sure the screen shown in the figure is displayed, then use  to pull out the media until its leading edge reaches the paper tube. Check to make sure the media is pulled out straight at this time. If the media is not straight, redo the loading operation. You can adjust the length of the media in 10-millimeter steps by pressing . (To pull out media continuously, hold down the key.)

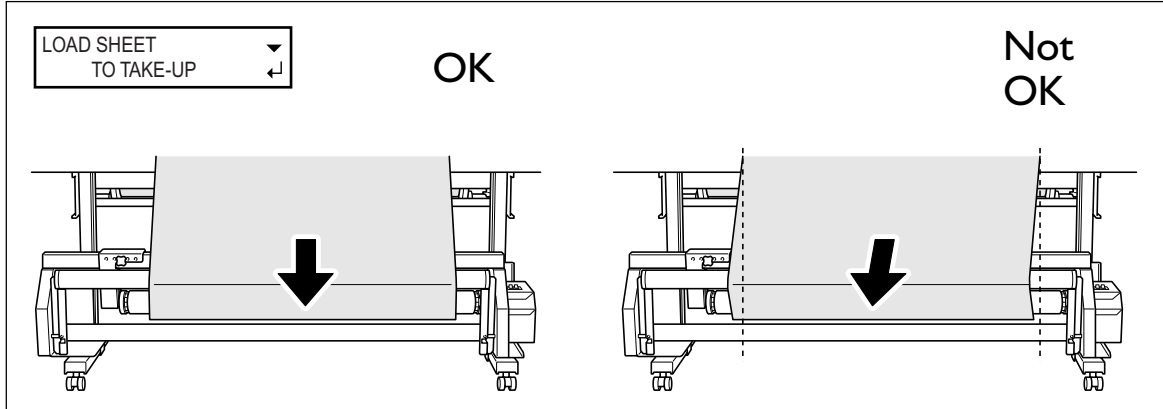

- ② Using adhesive tape, fasten the center and side edges of the media to the paper tube (fasten a total of three locations).
  - ① Secure the center of the media in place while keeping the media stretched taut to keep it free of slack.
  - ② While pulling the media from the center outward, fasten the left and right edges.

### Take-up with outward curl

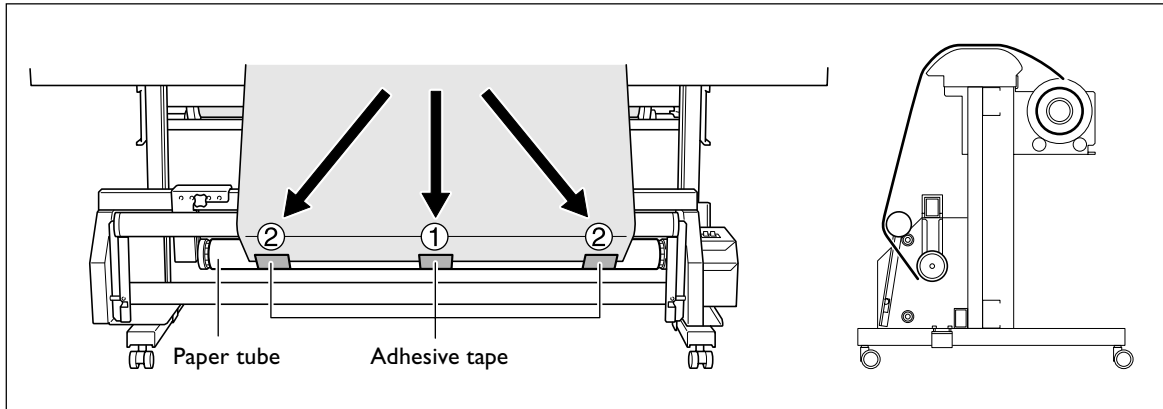

### Take-up with inward curl

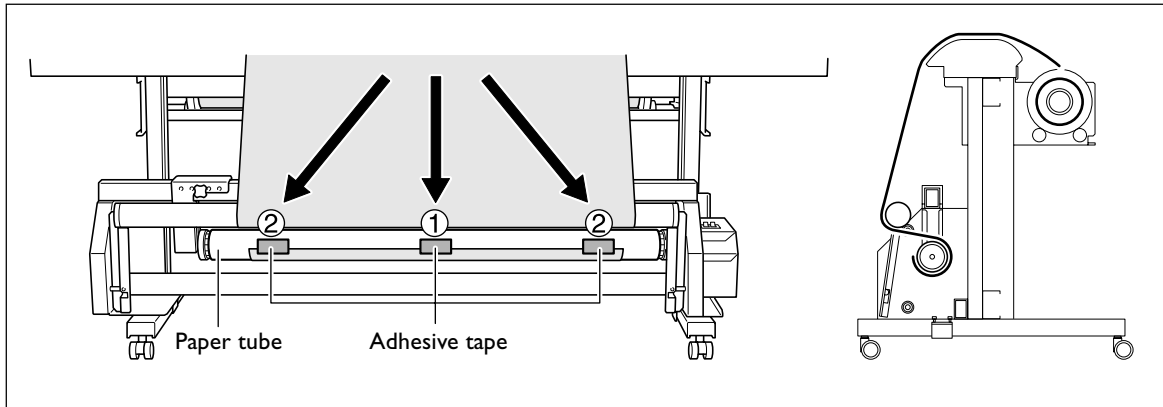



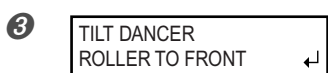

Press **ENTER**.

The media is pulled out and the screen shown in the figure appears.

- 4 Pull the dancer roller back toward you, then make sure the media is stretched taut, and press **ENTER**.

The screen shown in the figure appears.

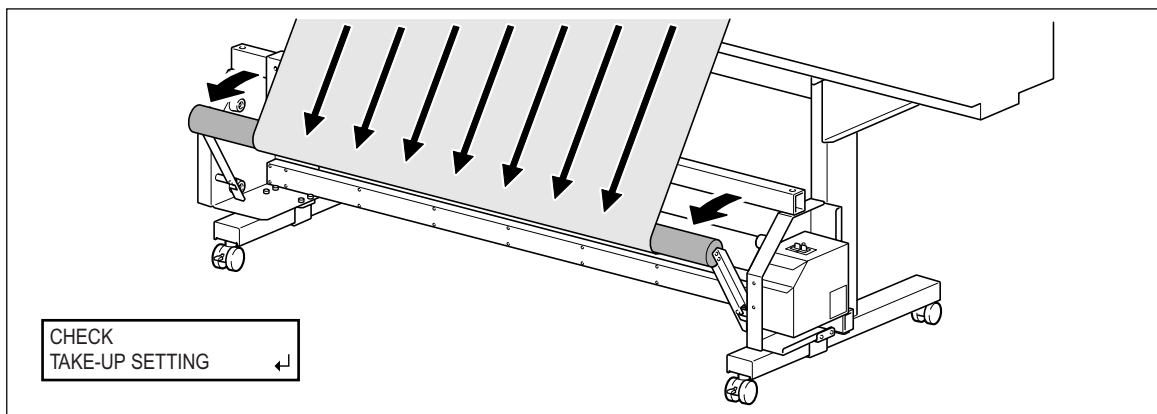

### 3. Take up the media.

- 1 Make the setting for the AUTO switch on the take-up unit.

Take-up with outward curl

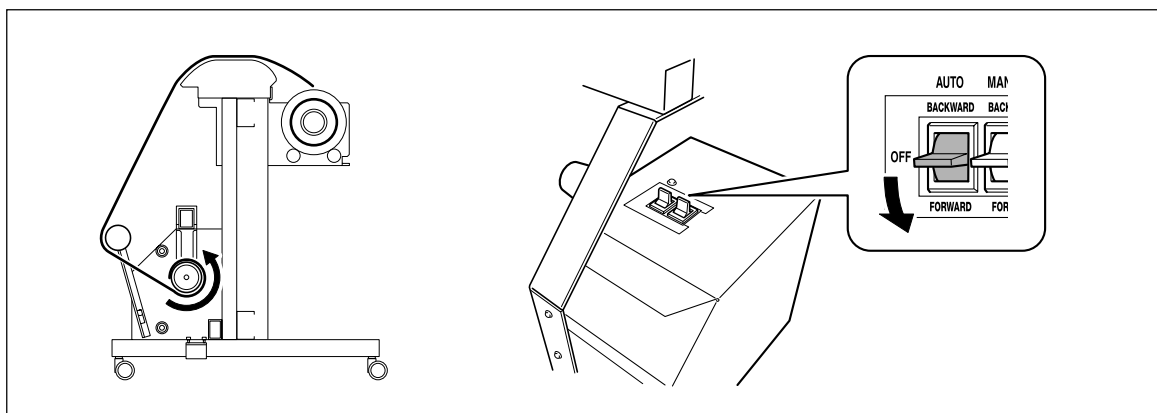

Take-up with inward curl

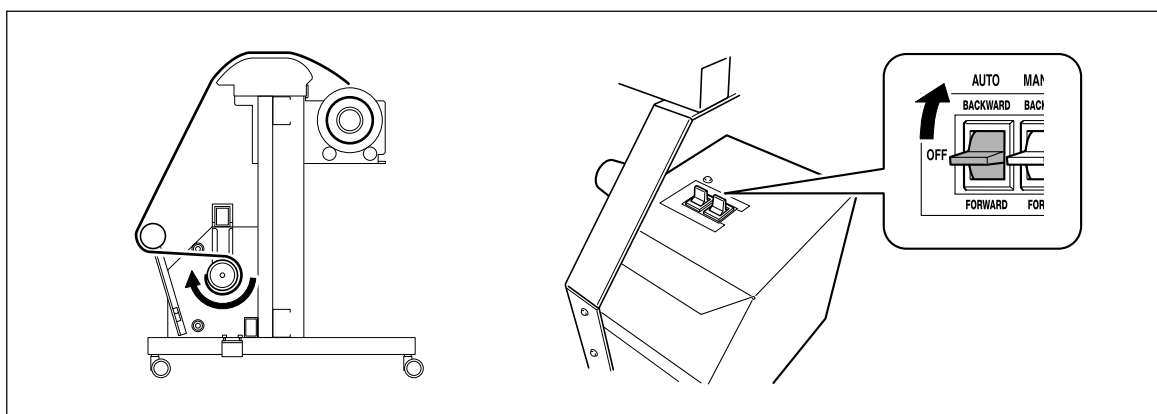

## 4. Operation

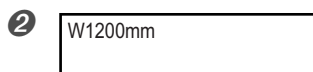

Press .

After the take-up unit takes up media for several passes, the screen shown in the figure appears.

When you begin take-up, take care to ensure that the end of the media does not become rolled or creased.

This completes loading of the media.

---

### PRO II/PRO IIV series, SP series

---

## 1. Pass the media through the printer.

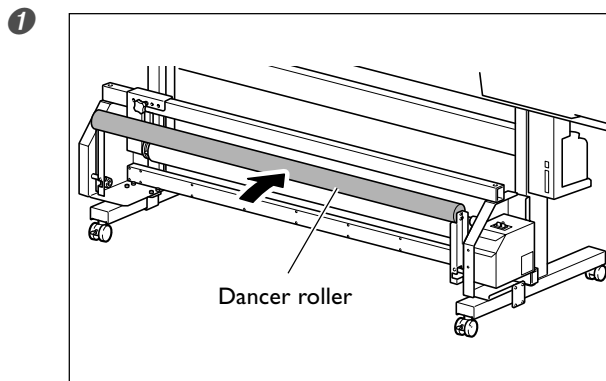

Move the dancer roller toward the rear.

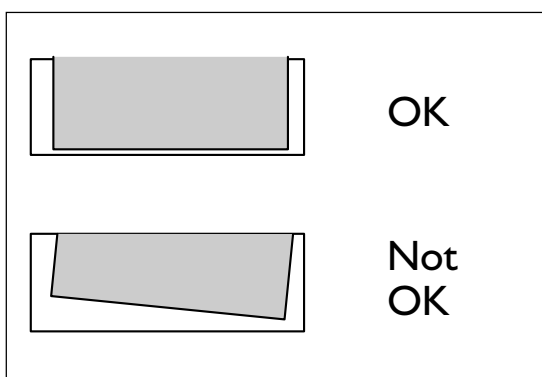
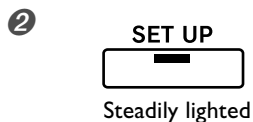

Load roll media onto the printer and put the printer in the setup state (so that  is illuminated).

For information on how to perform loading, refer to the user's manual for the printer.

After loading, check the following points.

- The media is loaded straight.
- All areas of the media are taut.

If the media is slack or crooked, cancel the setup state and reload the media.

③ Check to make sure the following setting-menu items on the printer are each set to "DISABLE."

- The [PREFEED] setting-menu item
- The [FEED FOR DRY] setting-menu item (only on models where this setting is available)

For information on how to check or change setting values, refer to the user's manual for the printer.

## 2. Fasten the media to the paper tube.

- ① Make sure **SET UP** is lighted, then use **▼** to pull out the media until its leading edge reaches the paper tube. Check to make sure the media is pulled out straight at this time. If the media is not straight, redo the loading operation.

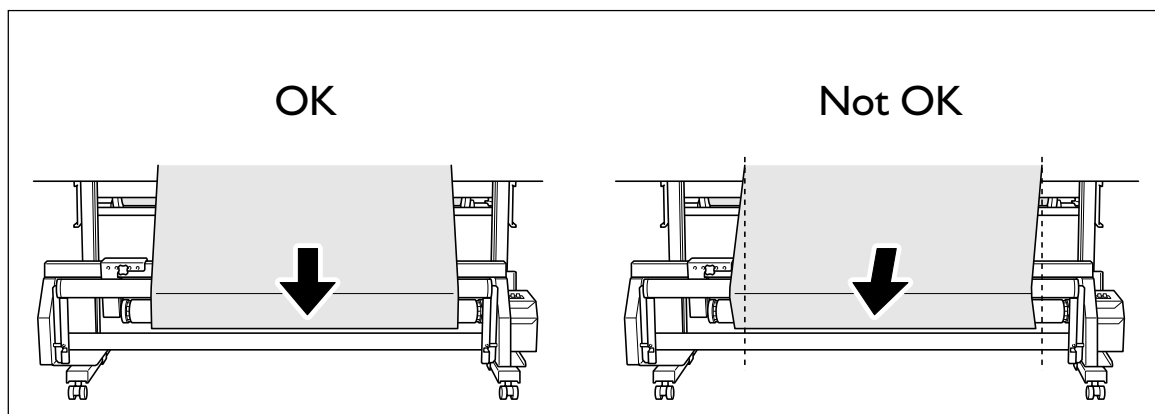

- ② Using adhesive tape, fasten the center and side edges of the media to the paper tube (fasten a total of three locations).
  - ① Secure the center of the media in place while keeping the media stretched taut to keep it free of slack.
  - ② While pulling the media from the center outward, fasten the left and right edges.

### Take-up with outward curl

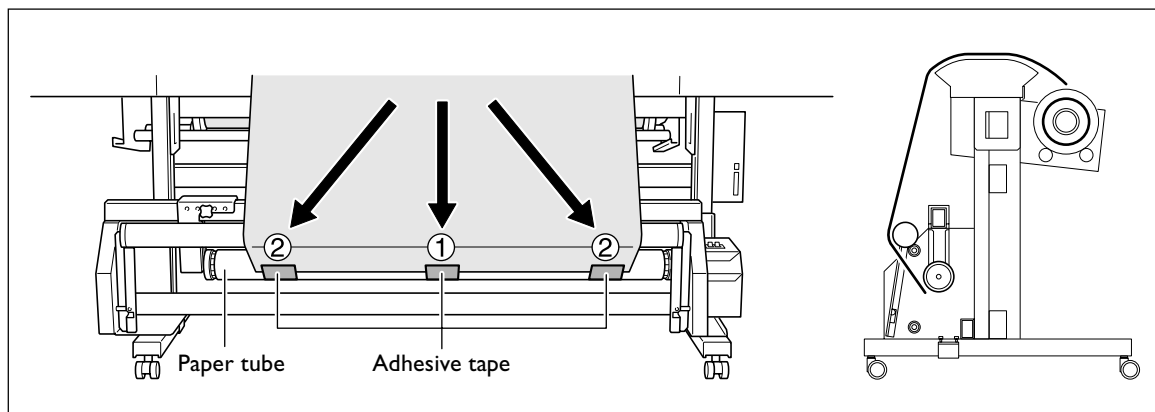

### Take-up with inward curl

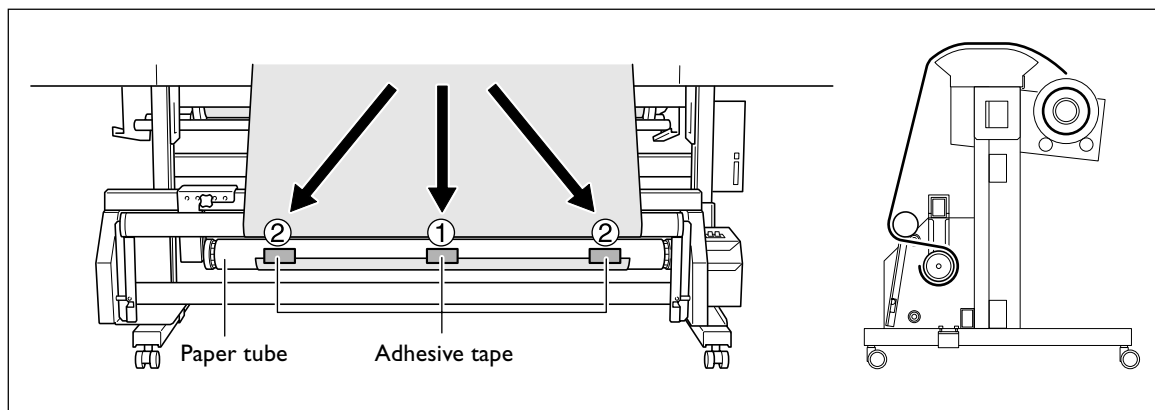

### 3. Take up the media.

① Make the setting for the AUTO switch on the take-up unit.

Take-up with outward curl

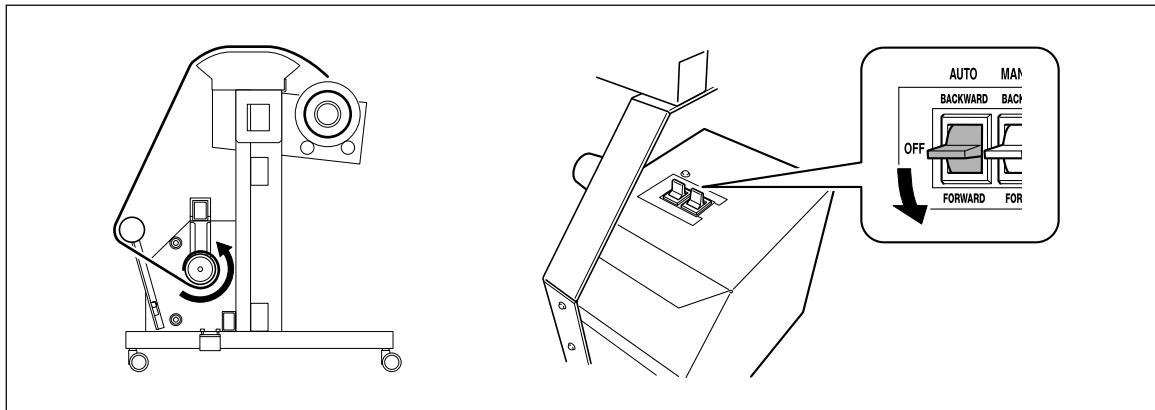

Take-up with inward curl

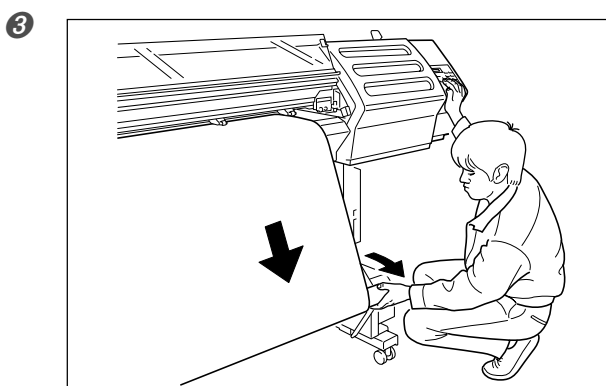
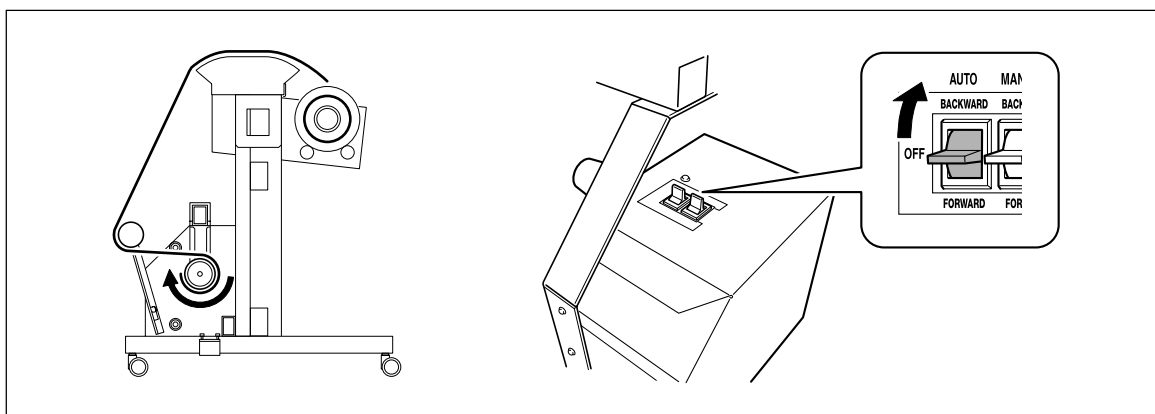

While supporting the dancer roller feed out media and take it up on the paper tube.

- ① While using  ▼ to feed out the media a little at a time, pull the dancer roller back toward you, stopping at a place where the dancer roller doesn't go back into the machine when you let go of it.
- ② Let go of the dancer roller, then press  ▼ again. When the take-up unit starts to perform take-up, release  ▼.

When you begin take-up, take care to ensure that the end of the media does not become rolled or creased.

5 Press **BASE POINT** key ( **BASE POINT** ).

Be sure to press **BASE POINT** and set the base point (the output-start location). Attempting to start printing with the base point left unset causes the media to be taken up with excessive force and results in a motor error.

This completes loading of the media.

## To Take up Media Manually

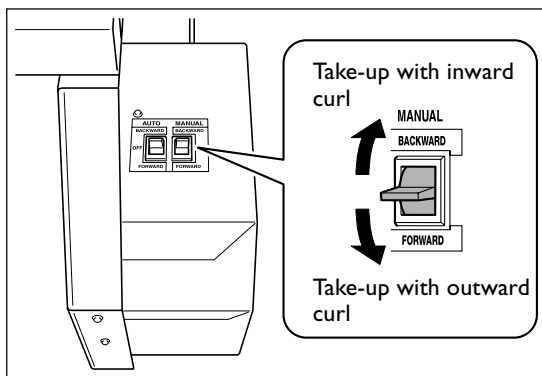

You can take up media by using the **MANUAL** switch. However, never operate the **MANUAL** switch while the loading lever is engaged (lowered). Doing so may cause the media to be pulled with excessive force, actuating the protective feature and resulting in an error.

## How to Remove Taken-up Media

**⚠ CAUTION** Removal of taken-up roll media from the unit is a task which must be carried out by two or more persons.  
If dropped, such items may cause injury.

- ① Cut off the media.  
For more information about how to perform cutoff, refer to the user's manual included with the printer.
- ② Support the paper tube to prevent it from falling.
- ③ Loosen the retaining screw and move the arm.
- ④ Detach the paper tube from the end caps.

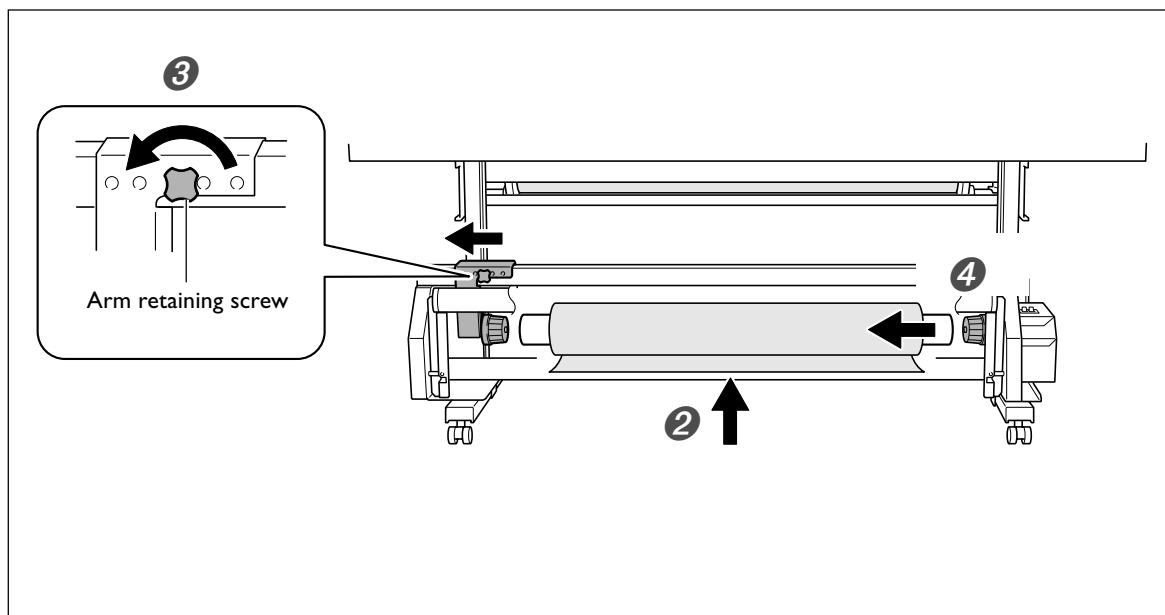

## 5. What to do if...

### The take-up unit doesn't take up media.

**Are the power cord and AC adapter connected correctly?**

Connect securely, so that the connection will not come loose or be incomplete.

**Is the AUTO switch set to [OFF]?**

Set the AUTO switch to match the direction of take-up.

**Is the setting for the AUTO switch at the correct position?**

Orient the setting of the AUTO switch to match the direction of take-up for the media.

**Is automatic cutoff of the media being performed?**

Take-up quits as soon as the media is cut off. On the computer (the software RIP), make the setting so that the printer doesn't perform automatic cutoff. For more information about the setting for automatic cutoff, refer to the documentation for the software RIP.

### Media take-up is not straight.

**Is the media loaded correctly?**

Remove the media, then redo media loading from the beginning.

# 6. Appendix

## Locations of the Power Rating and Serial Number Labels

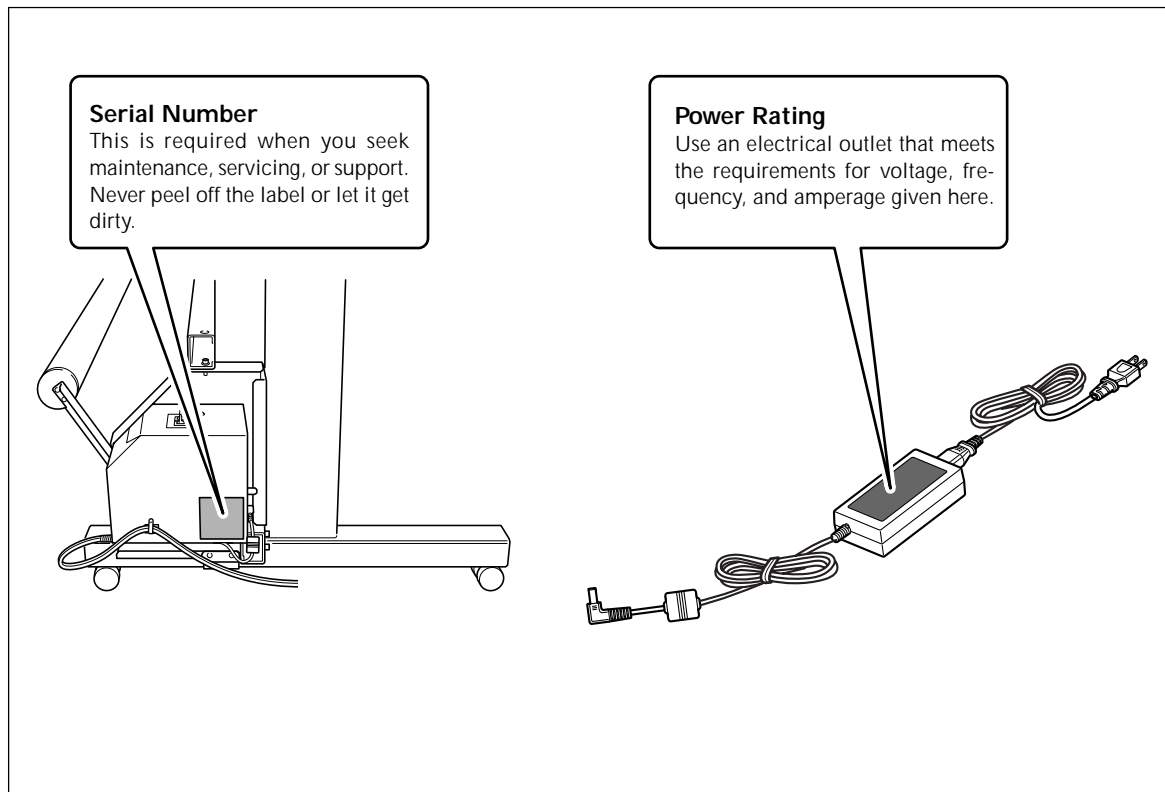

## Specifications

Rail and Accessories	TUC-2			
	TU2-74	TU2-64	TU2-54	TU2-30
Acceptable media widths	Less than 1,879 mm (74 in.)	Less than 1,625 mm (64 in.)	Less than 1,371 mm (54 in.)	Less than 762 mm (30 in.)
Acceptable media weights	Maximum 30 kg (*)			
Weight (Total including control box, rail, and accessories)	26.5 kg (58.4 lb.)	25 kg (55.1 lb.)	22 kg (48.5 lb.)	18.5 kg (40.8 lb.)
Power requirements	Dedicated AC adapter Input: AC 100 V to 240 V $\pm$ 10%, 50/60 Hz, 1.7 A Output: DC 19 V, 2.1 A			
Power consumption	Approx. 20 W			
Acoustic noise level	64 dB (A) or less (according to ISO7779)			
Environmental	Temperature: 5 to 40°C (41 to 104°F), humidity: 20 to 80%RH (non-condensing)			

(\*)

NOTE: The actual usable media weight may depend on the printer's conditions for usable media.





