



USER'S MANUAL **1**

Setup & Maintenance

*** Read First ***

Thank you very much for purchasing the MDX-650/500.

- To ensure correct and safe usage with a full understanding of this product's performance, please be sure to read through this manual completely and store it in a safe location.
- Unauthorized copying or transferral, in whole or in part, of this manual is prohibited.
- The contents of this operation manual and the specifications of this product are subject to change without notice.
- The operation manual and the product have been prepared and tested as much as possible. If you find any misprint or error, please inform us.
- Roland DG Corp. assumes no responsibility for any direct or indirect loss or damage which may occur through use of this product, regardless of any failure to perform on the part of this product.
- Roland DG Corp. assumes no responsibility for any direct or indirect loss or damage which may occur with respect to any article made using this product.

For the USA

FEDERAL COMMUNICATIONS COMMISSION RADIO FREQUENCY INTERFERENCE STATEMENT

This equipment has been tested and found to comply with the limits for a Class A digital device, pursuant to Part 15 of the FCC Rules.

These limits are designed to provide reasonable protection against harmful interference when the equipment is operated in a commercial environment.

This equipment generates, uses, and can radiate radio frequency energy and, if not installed and used in accordance with the instruction manual, may cause harmful interference to radio communications.

Operation of this equipment in a residential area is likely to cause harmful interference in which case the user will be required to correct the interference at his own expense.

Unauthorized changes or modification to this system can void the users authority to operate this equipment.

The I/O cables between this equipment and the computing device must be shielded.

For Canada

CLASS A NOTICE

This Class A digital apparatus meets all requirements of the Canadian Interference-Causing Equipment Regulations.

CLASSE A AVIS

Cet appareil numérique de la classe A respecte toutes les exigences du Règlement sur le matériel brouilleur du Canada.

NOTICE

Grounding Instructions

Do not modify the plug provided - if it will not fit the outlet, have the proper outlet installed by a qualified electrician.

Check with qualified electrician or service personnel if the grounding instructions are not completely understood, or if in doubt as to whether the tool is properly grounded.

Use only 3-wire extension cords that have 3-prong grounding plugs and 3-pole receptacles that accept the tool's plug.

Repair or replace damaged or worn out cord immediately.

Operating Instructions

KEEP WORK AREA CLEAN. Cluttered areas and benches invites accidents.

DON'T USE IN DANGEROUS ENVIRONMENT. Don't use power tools in damp or wet locations, or expose them to rain. Keep work area well lighted.

DISCONNECT TOOLS before servicing; when changing accessories, such as blades, bits, cutters, and like.

REDUCE THE RISK OF UNINTENTIONAL STARTING. Make sure the switch is in off position before plugging in.

USE RECOMMENDED ACCESSORIES. Consult the owner's manual for recommended accessories. The use of improper accessories may cause risk of injury to persons.

NEVER LEAVE TOOL RUNNING UNATTENDED.
TURN POWER OFF. Don't leave tool until it comes to a complete stop.

WARNING

This is a Class A product. In a domestic environment this product may cause radio interference in which case the user may be required to take adequate measures.

Table of Contents

To Ensure Safe Use	2
About the Labels Affixed to the Unit	5
Pour utiliser en toute sécurité	7
À propos des étiquettes collées sur l'appareil	10
How The Manuals Are Organized	13

Part 1 Setting Up

1-1	Checking the Accessories	14
1-2	Names of Parts	15
	Front	15
	Right Side	16
	Left Side	16
	MDX-650 Operation Panel	17
	MDX-500 Operation Panel	18
1-3	Setting Up and Connection Setting	19
	Setting Up	19
	MDX-650	20
	MDX-500	21
	Connection	22
1-4	Description of the Spindle Area	24
	About the Spindle Cover	24
	High-torque Spindle and High-speed Spindle	25
	Installable Optional Items for Different Spindles	25
	High-torque Spindle (Optional) Set	26
	Installing the High-torque Spindle (ZS-650T/ZS-500T)	26
	Installing the Tool	28
	Attaching the Brush Adapter for Chip Cleaning for the High-torque Spindle (ZAD-500T)	31
	High-speed Spindle (Optional) Set	32
	Installing the High-speed Spindle (ZS-500SH)	32
	Installing the Tool	34
	Attaching the Brush Adapter for Chip Cleaning for the High-speed Spindle (ZAD-500S)	40

1-5	Selection of the Command Set	41
	Selecting the Command Set on the MDX-650/500	41
1-6	Choosing the Spindle Type	42
1-7	The Cutting Area	43
	MDX-650	43
	MDX-500	45
1-8	Loading a Workpiece for Cutting	47

Part 2 Maintenance

2-1	Cleaning	49
	Cleaning the Main Unit	49
	Cleaning After Operation	49
	Cleaning the Sponge in the Fan-motor Area (MDX-500 Only)	51
2-2	Checking the Spindle	52
	Checking the Spindle Motor	52
	Display of Spindle Rotation Time	52
	Adjusting the Tension of the Spindle Belt ..	53
2-3	Lubricating the Ball Screw	55
2-4	Recommended Service Checking	57

Part 3 Appendix

3-1	The ZA-500 Series Spacer for the T-slot Table (Optional)	58
	Checking the Accessories	58
	Installing on the MDX-650/500	58
3-2	Other Optional Items	60
3-3	Specifications	61

Windows® and MS-DOS are registered trademarks or trademarks of Microsoft® Corporation in the United States and/or other countries.

IBM is a registered trademark of International Business Machines Corporation.



Other company names and product names are trademarks or registered trademarks of their respective holders.

Copyright © 2001 Roland DG Corporation



<http://www.rolanddg.com/>

To Ensure Safe Use

About ⚠️ WARNING and ⚠️ CAUTION Notices

 WARNING	Used for instructions intended to alert the user to the risk of death or severe injury should the unit be used improperly.
 CAUTION	Used for instructions intended to alert the user to the risk of injury or material damage should the unit be used improperly. * Material damage refers to damage or other adverse effects caused with respect to the home and all its furnishings, as well to domestic animals or pets.

About the Symbols

	The ⚠️ symbol alerts the user to important instructions or warnings. The specific meaning of the symbol is determined by the design contained within the triangle. The symbol at left means "danger of electrocution."
	The ⚡ symbol alerts the user to items that must never be carried out (are forbidden). The specific thing that must not be done is indicated by the design contained within the circle. The symbol at left means the unit must never be disassembled.
	The ● symbol alerts the user to things that must be carried out. The specific thing that must be done is indicated by the design contained within the circle. The symbol at left means the power-cord plug must be unplugged from the outlet.

⚠️ WARNING



Do not disassemble, repair, or modify.

Doing so may lead to fire or abnormal operation resulting in injury.



Do not use with any electrical power supply that does not meet the ratings displayed on the unit.

Use with any other power supply may lead to fire or electrocution.



Ground the unit with the ground wire.

Failure to do so may result in risk of electrical shock in the even of a mechanical problem



Do not use while in an abnormal state (i.e., emitting smoke, burning odor, unusual noise, or the like).

Doing so may result in fire or electrical shock.

Immediately switch off the power, unplug the power cord from the electrical outlet, and contact your authorized Roland DG Corp. dealer or service center.



Use only with the power cord included with this product.

Use with other than the included power cord may lead to fire or electrocution.

CAUTION



Do not use with a damaged power cord or plug, or with a loose electrical outlet.

Use with any other power supply may lead to fire or electrocution.

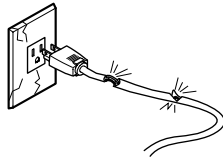

When not in use for extended periods, unplug the power cord from the electrical outlet.

Failure to do so may result in danger of shock, electrocution, or fire due to deterioration of the electrical insulation.

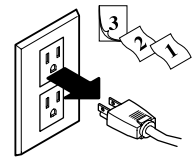

Do not injure or modify the electrical power cord, nor subject it to excessive bends, twists, pulls, binding, or pinching, nor place any object of weight on it.

Doing so may damage the electrical power cord, leading to electrocution or fire.

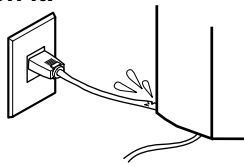

When unplugging the electrical power cord from the power outlet, grasp the plug, not the cord.

Unplugging by pulling the cord may damage it, leading to fire or electrocution.

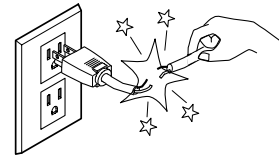

Do not attempt to unplug the power cord with wet hands.

Doing so may result in electrical shock.

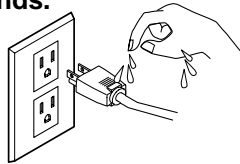

Do not connect the power cord with other electrical loads on a single electrical outlet.

Doing so may generate heat and cause fire.



Install on a stable surface.

Failure to do so may result in falling of the unit, leading to injury.

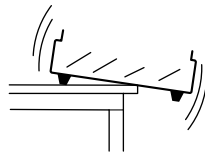

When moving, grasp the aluminum base portion at the bottom portion of the unit, and carry out the operation with five or more persons for the MDX-650 or with four or more persons for the MDX-500.

If grasped by the rear cover, the unit may fall, resulting in injury.

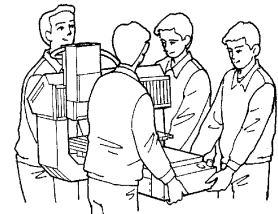

Unpacking, installation, and moving are operations that must be carried out by five or more persons for the MDX-650 and by four or more persons for the MDX-500.

Failure to do so may result in falling of the unit, leading to injury.

(The MDX-650 weighs 120 kg (264.5 lb.), and the MDX-500 weighs 92 kg (202.8 lb.).)

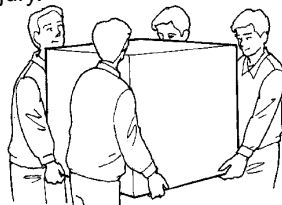

Fasten the spindle, tool, and material securely in place.

Otherwise they may come loose during cutting, resulting in injury.

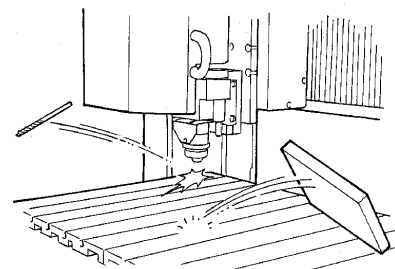

Do not touch the tip of the blade with your fingers.

Doing so may result in injury.



CAUTION



Do not insert the fingers between the XY table and base or between the head and Z cover.

Doing so may result in injury.

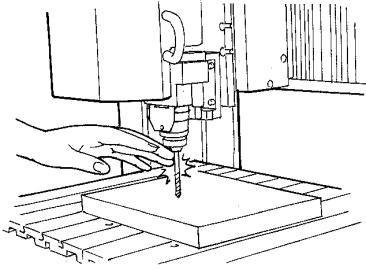

Do not insert the fingers between the T-slot table and arms or between the head and Z cover.

The fingers may be pinched, resulting in injury.

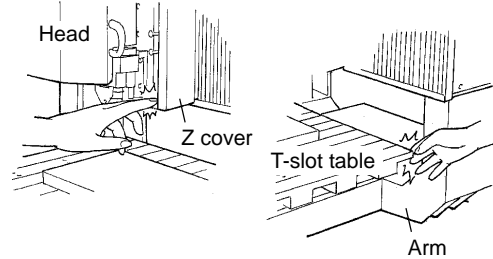

Do not place anything within the moving area of the T-slot table.

The object may bump into the T-slot table and fall, resulting in injury.

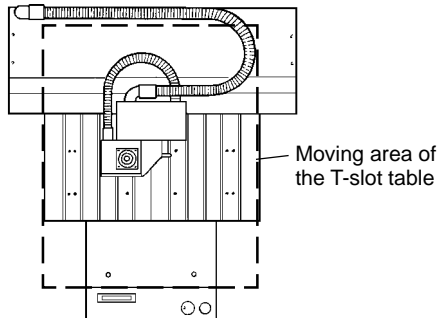

Wear dust goggles and mask during use.

Cutting dust may scatter, causing bodily injury.



Use a commercially available brush to remove metal cuttings.

Attempting to use a vacuum cleaner to take up metal cuttings may cause fire in the vacuum cleaner.



Do not wear gloves, a necktie or wide-sleeved clothing.

They may become caught in the tool, resulting in injury.

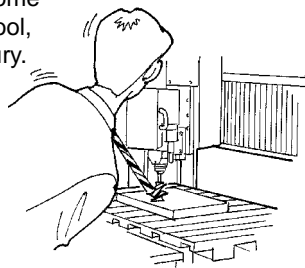

Do not allow liquids, metal objects or flammables inside the machine.

Such materials can cause fire.

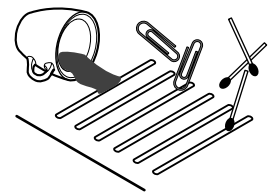

Do not operate beyond capacity or subject the tool to undue force.

The tool may break or fly off in a random direction. If cutting beyond capacity is mistakenly started, immediately turn off the EMERGENCY STOP switch.



Perform dry cutting with no cutting oil.

Such materials can cause fire.

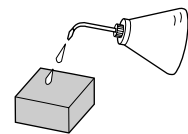

CAUTION



Do not touch the tool immediately after cutting operating stops.

The tool may have become hot due to friction heat and may cause burns if touched.



Switch off the machine and unplug the power cord from the electrical outlet before performing cleaning or maintenance.

Failure to do so may result in injury or electrical shock.



When you're finished, wash your hands to rinse away all cuttings.



Please use a vacuum cleaner to remove cutting dust. Do not use any blower like airbrush.

Otherwise, dust spread in the air may harm your health.

About the Labels Affixed to the Unit

These labels are affixed to the body of this product.

The following figure describes the location and content of these messages.

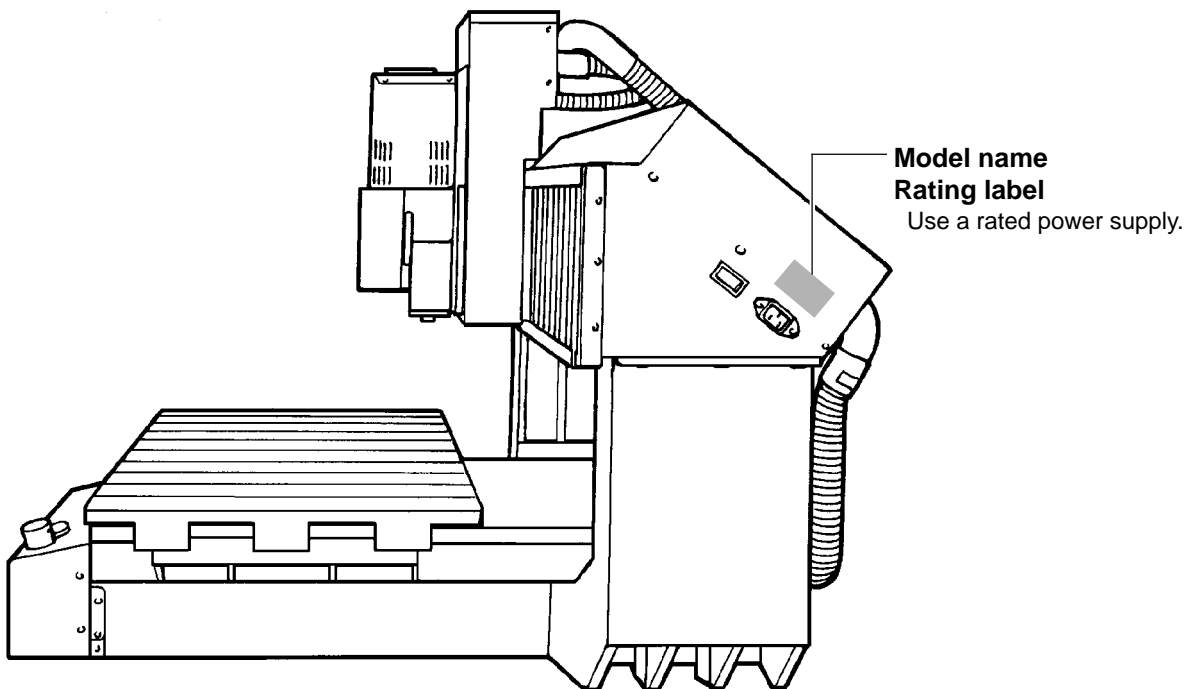



Handle tool with care.

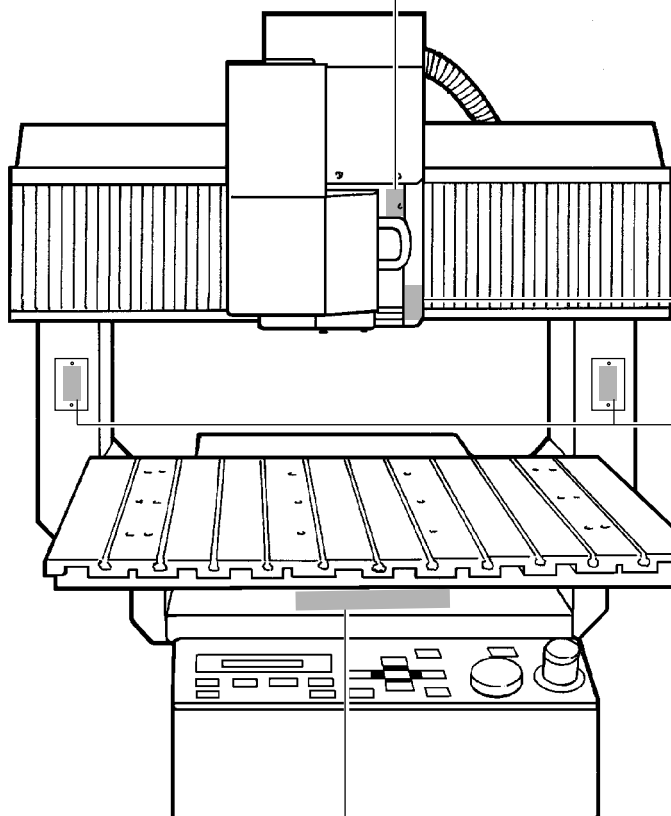

Do not insert fingers between the head and Z cover during operation.

Do not insert fingers between the T-slot table and arms during operation.

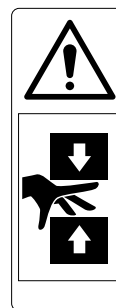

<p>▲ CAUTION Please use a vacuum cleaner to remove cutting dust. Do not use any blower like airbrush. Otherwise, dust spread in the air may harm your health or damage this machine.</p>	<p>▲ VORSICHT Bitte entfernen Sie Staub mit einem Staubsauger. Niemals ein Gebläse verwenden. Der dadurch freigesetzte Staub ist gesundheitsschädlich und kann die Funktion Ihres Geräts beeinträchtigen.</p>
<p>▲ PRECAUCION Por favor, utilice un aspirador para limpiar la viruta y el polvo. No utilice aire a presión para la limpieza, podría averiar la máquina, y no sería conveniente para su salud respirar el polvo.</p>	<p>▲ CAUTELA Usare un aspiratore per rimuovere polvere o trucioli da lavorazione. Non usare compressori, altrimenti la polvere diffusa nell'aria potrebbe essere nociva alla salute o danneggiare la macchina.</p>
<p>▲ PRUDENCE Veuillez utiliser un aspirateur pour enlever la poussière. Ne jamais utiliser de projecteurs d'air. La poussière soufflée dans l'air peut causer des problèmes de respiration et endommager votre machine.</p>	<p>▲ 注意 切削粉は吸い込み型のクリーナーを使用して除去して下さい。吹き飛ばすエアガンは使用しないで下さい。切削粉が飛び散り健康の障害になったり、機器に侵入し故障の原因となります。</p>

In addition to the **▲ WARNING** and **▲ CAUTION** symbols, the symbols shown below are also used.



NOTICE : Indicates information to prevent machine breakdown or malfunction and ensure correct use.









: Indicates a handy tip or advice regarding use.

Pour utiliser en toute sécurité

Avis sur les avertissements

 ATTENTION	Utilisé pour avertir l'utilisateur d'un risque de décès ou de blessure grave en cas de mauvaise utilisation de l'appareil.
 PRUDENCE	Utilisé pour avertir l'utilisateur d'un risque de blessure ou de dommage matériel en cas de mauvaise utilisation de l'appareil. * Par dommage matériel, il est entendu dommage ou tout autre effet indésirable sur la maison, tous les meubles et même les animaux domestiques.

À propos des symboles

	Le symbole  attire l'attention de l'utilisateur sur les instructions importantes ou les avertissements. Le sens précis du symbole est déterminé par le dessin à l'intérieur du triangle. Le symbole à gauche signifie "danger d'électrocution".
	Le symbole  avertit l'utilisateur de ce qu'il ne doit pas faire, ce qui est interdit. La chose spécifique à ne pas faire est indiquée par le dessin à l'intérieur du cercle. Le symbole à gauche signifie que l'appareil ne doit jamais être démonté.
	Le symbole  prévient l'utilisateur sur ce qu'il doit faire. La chose spécifique à faire est indiquée par le dessin à l'intérieur du cercle. Le symbole à gauche signifie que le fil électrique doit être débranché de la prise.

ATTENTION



Ne pas démonter, réparer ou modifier.

Le non-respect de cette consigne pourrait causer un incendie ou provoquer des opérations anormales entraînant des blessures.



Utiliser seulement avec une alimentation de mêmes caractéristiques électriques que celles indiquées sur l'appareil.

Une négligence à ce niveau pourrait provoquer un incendie ou une électrocution.



Mettre l'appareil à la masse avec une prise de terre.

Le non-respect de cette consigne pourrait entraîner des décharges électriques en cas de problème mécanique.



Ne pas utiliser si l'appareil est dans un état anormal (c'est-à-dire s'il y a émission de fumée, odeur de brûlé, bruit inhabituel etc.).

Le non-respect de cette consigne pourrait provoquer un incendie ou des décharges électriques.

Couper immédiatement l'alimentation secondaire et ensuite l'alimentation principale. Débranchez le fil électrique et contacter votre revendeur ou votre centre de service de la société Roland DG autorisé.



N'utilisez que le cordon d'alimentation fourni avec ce produit.

L'utilisation avec un autre cordon d'alimentation que celui fourni pourrait entraîner un risque d'incendie ou d'électrocution.

PRUDENCE



Ne pas utiliser avec une fiche ou un fil électrique endommagé ou avec une prise mal fixée.

Une négligence à ce niveau pourrait provoquer un incendie ou une électrocution.

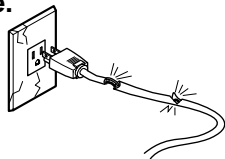

Débrancher le fil lorsque l'appareil reste inutilisé pendant une longue période.

Une négligence à ce niveau pourrait provoquer des décharges électriques, une électrocution ou un incendie dû à une détérioration de l'isolation électrique.

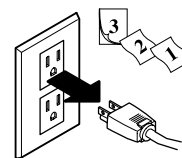

Ne pas endommager ou modifier le fil électrique. Ne pas le plier, le tordre, l'étirer, l'attacher ou le serrer de façon excessive. Ne pas mettre d'objet ou de poids dessus.

Une négligence à ce niveau pourrait endommager le fil électrique ce qui risquerait de provoquer une électrocution ou un incendie.

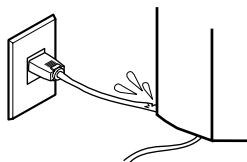

Saisir la fiche et non le fil électrique lorsque vous débranchez.

Débrancher en tirant sur le fil pourrait l'endommager et risquer de provoquer un incendie ou une électrocution.

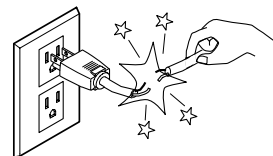

Ne pas essayer de débrancher le fil avec des mains mouillées.

Une négligence à ce niveau pourrait provoquer des décharges électriques.

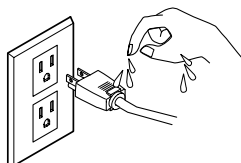

Ne pas brancher d'autres appareils sur la même prise.

Cela pourrait engendrer une surchauffe et provoquer un incendie.



Installer l'appareil sur une surface stable.

Une négligence à ce niveau pourrait provoquer la chute de l'appareil et entraîner des blessures.

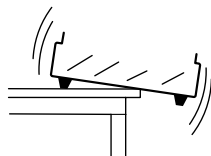

Pour déplacer l'appareil, saisir la base en aluminium sous l'appareil. Il faut cinq personnes ou plus pour déplacer le MDX-650, et quatre personnes ou plus pour déplacer le MDX-500.

Si l'appareil est saisi par la plaque du dessus, il peut tomber et entraîner des blessures.

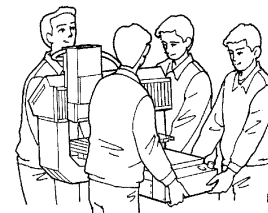

Il faut cinq personnes ou plus pour déballer, installer et déplacer le MDX-650, et quatre personnes ou plus pour le MDX-500.

Sinon, l'appareil pourrait tomber et entraîner des blessures.
(Le poids du MDX-650 est de 120 kg, et celui du MDX-500 est de 92 kg.)

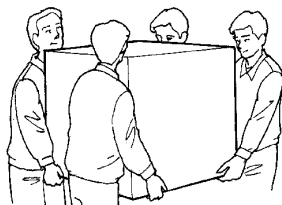

Ne pas toucher à l'extrémité de la lame avec vos doigts.

Vous risqueriez de vous blesser en y touchant.



PRUDENCE



Fixer fermement le mandrin, l'outil et le matériel à leur place.

Sinon, ces éléments risquent d'avoir du jeu lors des coupes, ce qui entraînerait des blessures.

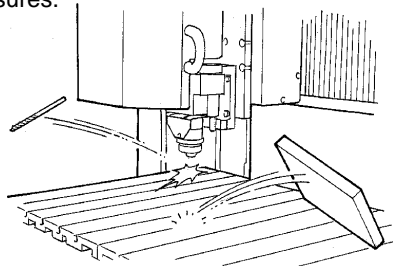

Ne pas insérer vos doigts entre la table XY et la base ou entre la tête et la plaque Z.

Cela pourrait entraîner des blessures.

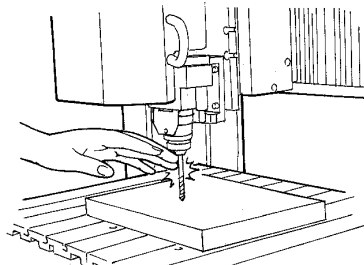

Ne pas insérer vos doigts entre la table à fente en T et les bras ou entre la tête et la plaque Z.

Vous pourriez vous pincer les doigts et vous blesser.

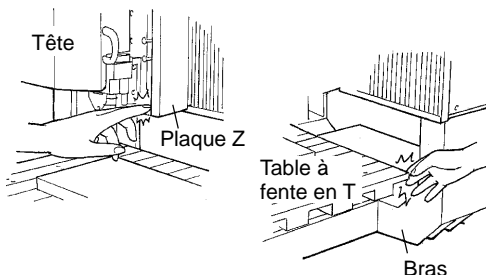

Ne rien placer dans l'espace mobile de la table à fente en T.

L'objet pourrait se heurter contre la table à fente en T et tomber, ce qui pourrait entraîner des blessures.

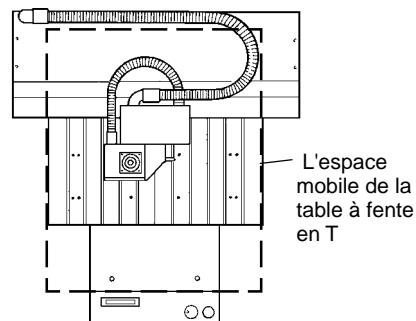

Porter des lunettes de travail et un masque durant l'utilisation.

Des copeaux pourraient être projetés et vous blesser.



Utiliser une brosse du commerce pour retirer les rognures de métal.

Tenter de retirer les rognures de métal à l'aide d'un aspirateur peut faire naître un incendie dans l'aspirateur.

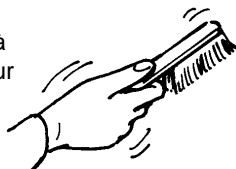

Ne pas porter de gants, de cravate ou de vêtement à manches amples.

Ils pourraient se prendre dans l'appareil et entraîner des blessures.

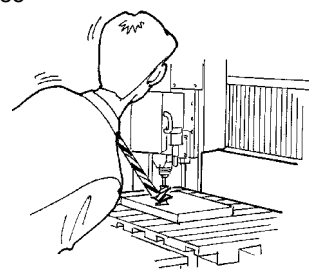

Ne pas introduire de liquide, d'objet métallique ou inflammable dans l'appareil.

Ce genre de matériel peut provoquer un incendie.

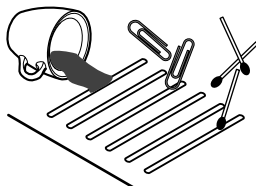

Ne pas utiliser l'appareil au-dessus de ses capacités ou le soumettre à une force excessive.

L'outil pourrait se briser ou être projeté dans une direction indéterminée. Si vous commencez par inadvertance une coupe au-dessus de la capacité de l'appareil, l'éteindre immédiatement à l'aide du bouton d'urgence.

PRUDENCE



Ne pas toucher l'outil immédiatement après une coupe.

L'outil pourrait avoir chauffé avec la friction et vous causer des brûlures.



Couper le contact et débrancher le câble d'alimentation du réceptacle avant de procéder au nettoyage ou à l'entretien de l'appareil.

Une négligence à ce niveau pourrait provoquer des blessures ou une électrocution.



Quand vous avez terminé d'utiliser l'appareil, laver vos mains pour bien enlever tous les copeaux.



Utiliser un aspirateur pour nettoyer les copeaux. N'utiliser aucun appareil soufflant de l'air comme un sèche-cheveux.

La poussière répandue dans l'air pourrait nuire à votre santé.

À propos des étiquettes collées sur l'appareil

Ces étiquettes sont collées à l'extérieur de l'appareil.

Les dessins suivants indiquent l'endroit et le contenu des messages.

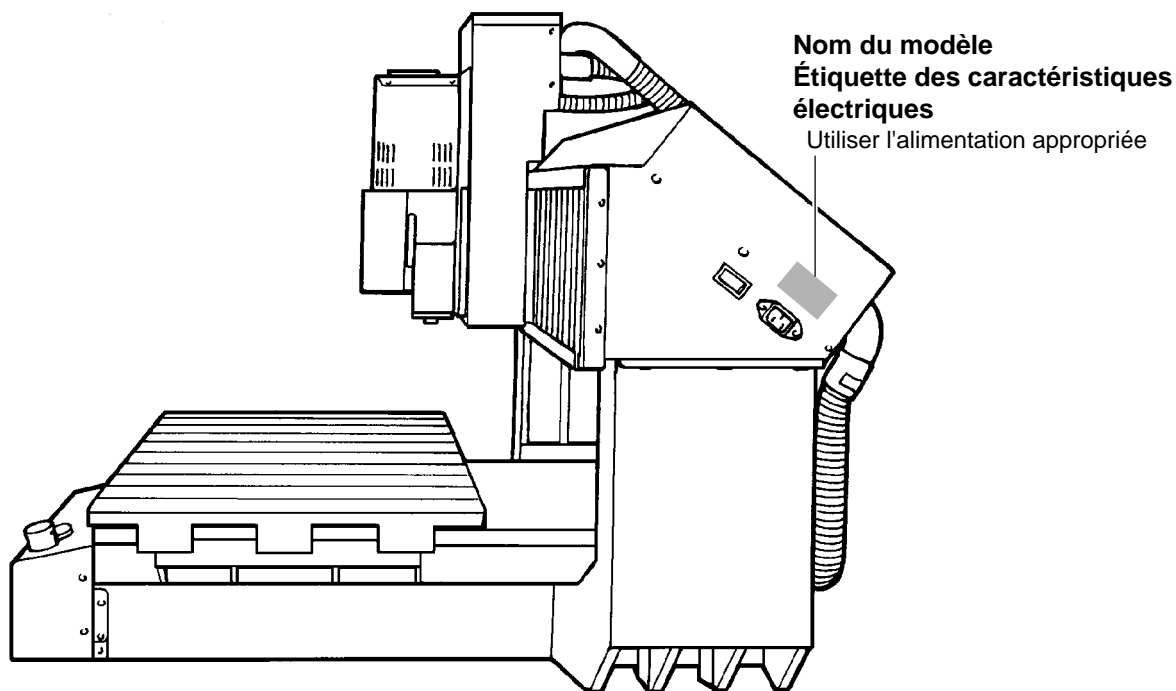



Manipuler l'outil
avec précaution.

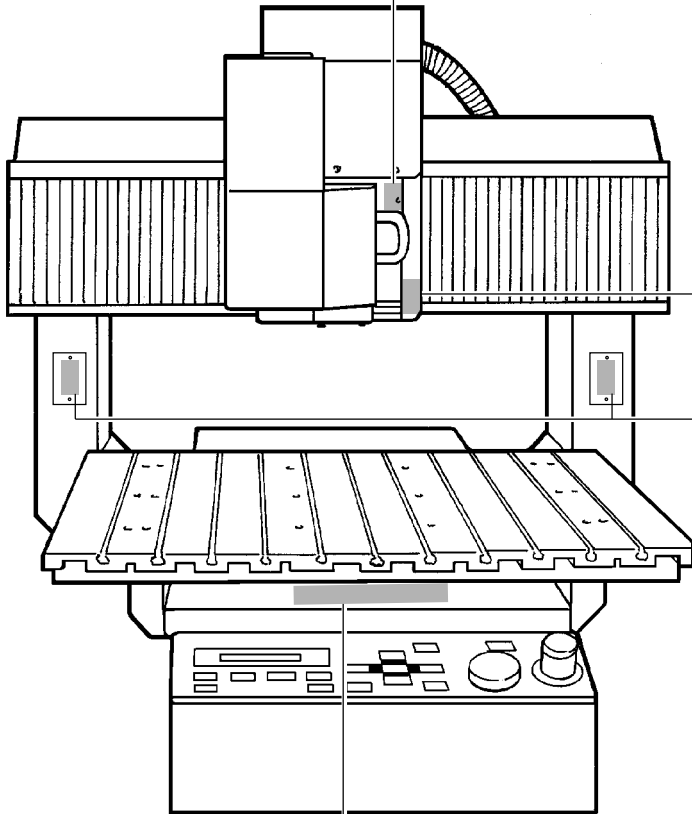

Ne pas insérer vos
doigts entre la tête et la
plaque Z quand l'appareil
est en marche.

Ne pas insérer vos doigts
entre la table à fente en T
et les bras quand
l'appareil est en marche.



▲ CAUTION

Please use a vacuum cleaner to remove cutting dust.
Do not use any blower like airbrush. Otherwise, dust
spread in the air may harm your health or damage this
machine.

▲ PRECAUCION

Por favor, utilice un aspirador para limpiar la viruta y el
polvo.
No utilice aire a presión para la limpieza, podría averiar la
maquina, y no sería conveniente para su salud respirar el
polvo.

▲ PRUDENCE

Veuillez utiliser un aspirateur pour enlever la poussière.
Ne jamais utiliser de projecteurs d'air. La poussière
soufflée dans l'air peut causer des problèmes de
respiration et endommager votre machine.

▲ VORSICHT

Bitte entfernen Sie Staub mit einem Staubsauger.
Niemals ein Gebläse verwenden. Der dadurch freigesetzte
Staub ist gesundheitsschädlich und kann die Funktion
Ihres Geräts beeinträchtigen.

▲ CAUTELA

Usare un aspiratore per rimuovere polvere o trucioli da
lavorazione.
Non usare compressori, altrimenti la polvere diffusa
nell'aria potrebbe essere nociva alla salute o danneggiare
la macchina.

▲ 注意

切削粉は吸い込み型のクリーナーを使用して除去して下さい。
吹き飛ばすエアガンは使用しないで下さい。
切削粉が飛び散り健康の障害になったり、機器に侵入し
故障の原因となります。

MEMO

How The Manuals Are Organized

The manuals for the MDX-650/500 are organized as follows. Refer to the appropriate one according to the purpose at hand.

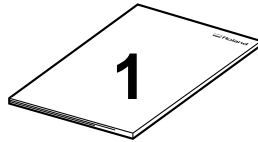

USER'S MANUAL 1 **"Setup & Maintenance"**

This describes installation, connection, preparations for starting cutting, and the care and maintenance of the machine.

When cutting
using RML-1

When cutting
using NC codes

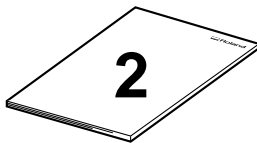

USER'S MANUAL 2 **"Cutting Using the Included Software"**

This describes operation methods when using the included software to perform cutting.

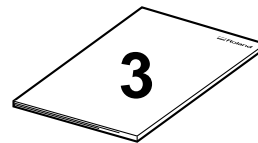

USER'S MANUAL 3 **"Cutting Using NC Codes"**

This describes operation methods when using NC codes to perform cutting.

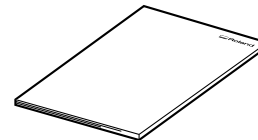

NC code **PROGRAMMER'S MANUAL**

This describes the NC codes supported by the MDX-650/500. It explains the basics of programming as well as each code.

* If you're using the MDX-650 with the optional rotary axis unit (ZCL-650), also see the "ZCL-650 User's Manual" included with the rotary axis unit.

Part 1 Setting Up

1-1 Checking the Accessories

The following items are packed together with the unit.

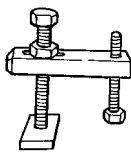

T-slot clamps : 4
(For installing the work)

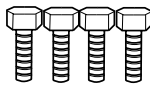

Bolts (5 x 25 mm) : 4
(For installing the T-slot clamp)

* These bolts are for the substitutions when the original bolts on the T-slot clamp are too long.



Wrench (10 mm (3/8 in.))
(For securing the T-slot clamps in place)



Z0 position sensor

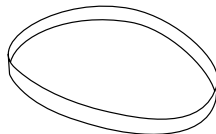

Belt for high-torque spindle

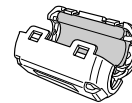

Ferrite core
* MDX-650 only

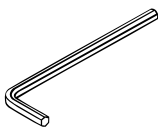

Hexagonal wrench



Key connector

* The machine does not run unless this is inserted.

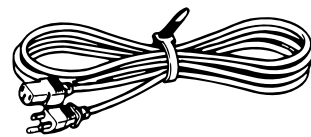

Power cord



Roland Software Package
CD-ROM

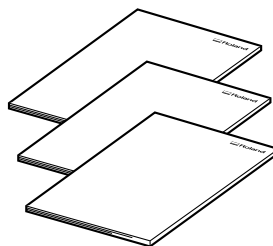

USER'S MANUAL
(1 Setup & Maintenance)
(2 Cutting Using the Included Software)
(3 Cutting Using NC codes)

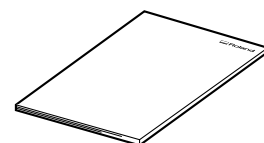

NC Code
PROGRAMMER'S MANUAL

1-2 Names of Parts

Front

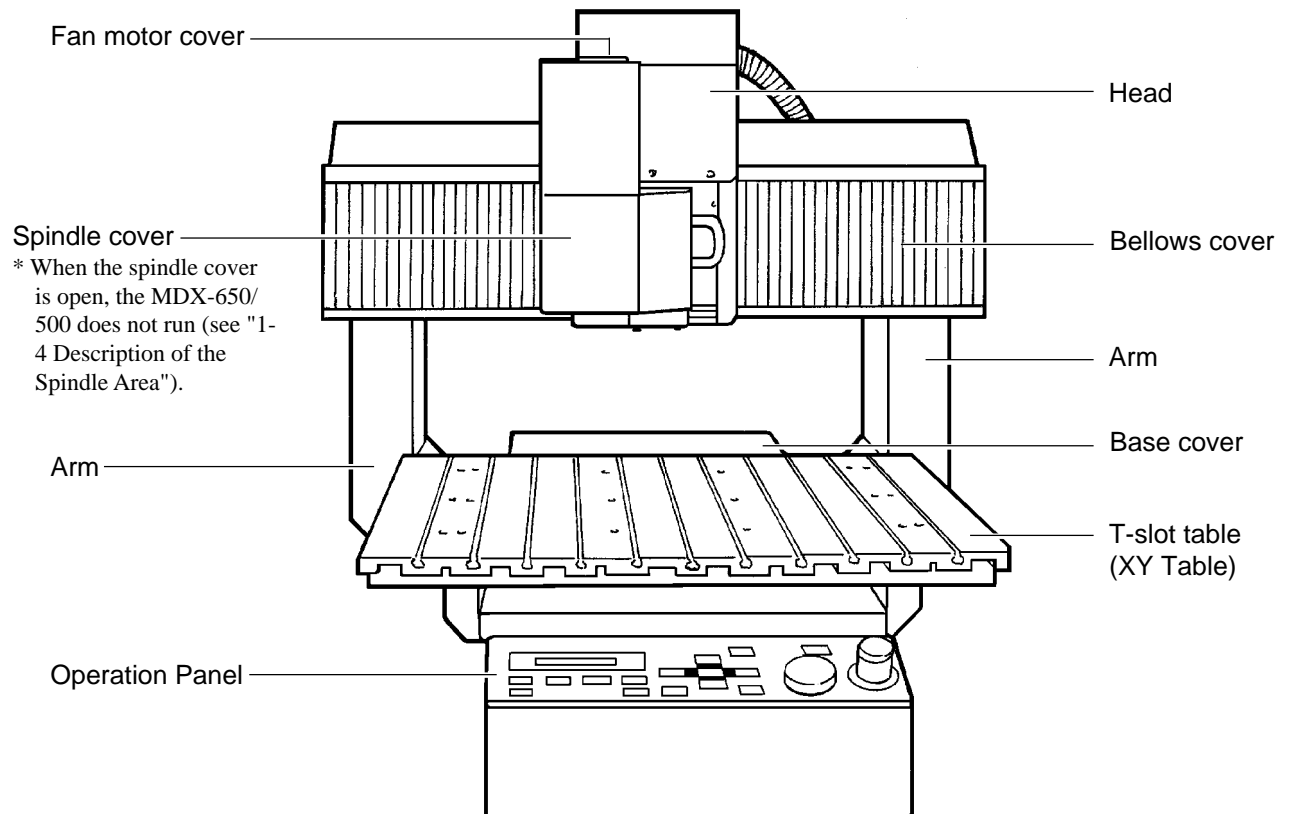

Right Side

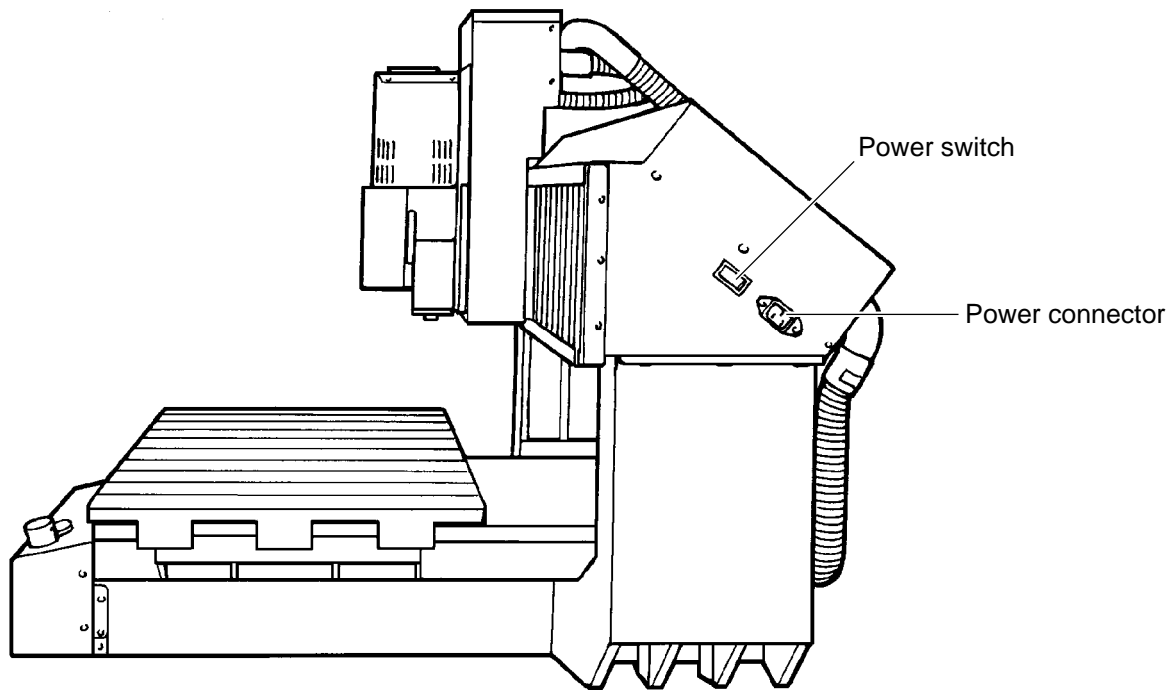

Left Side

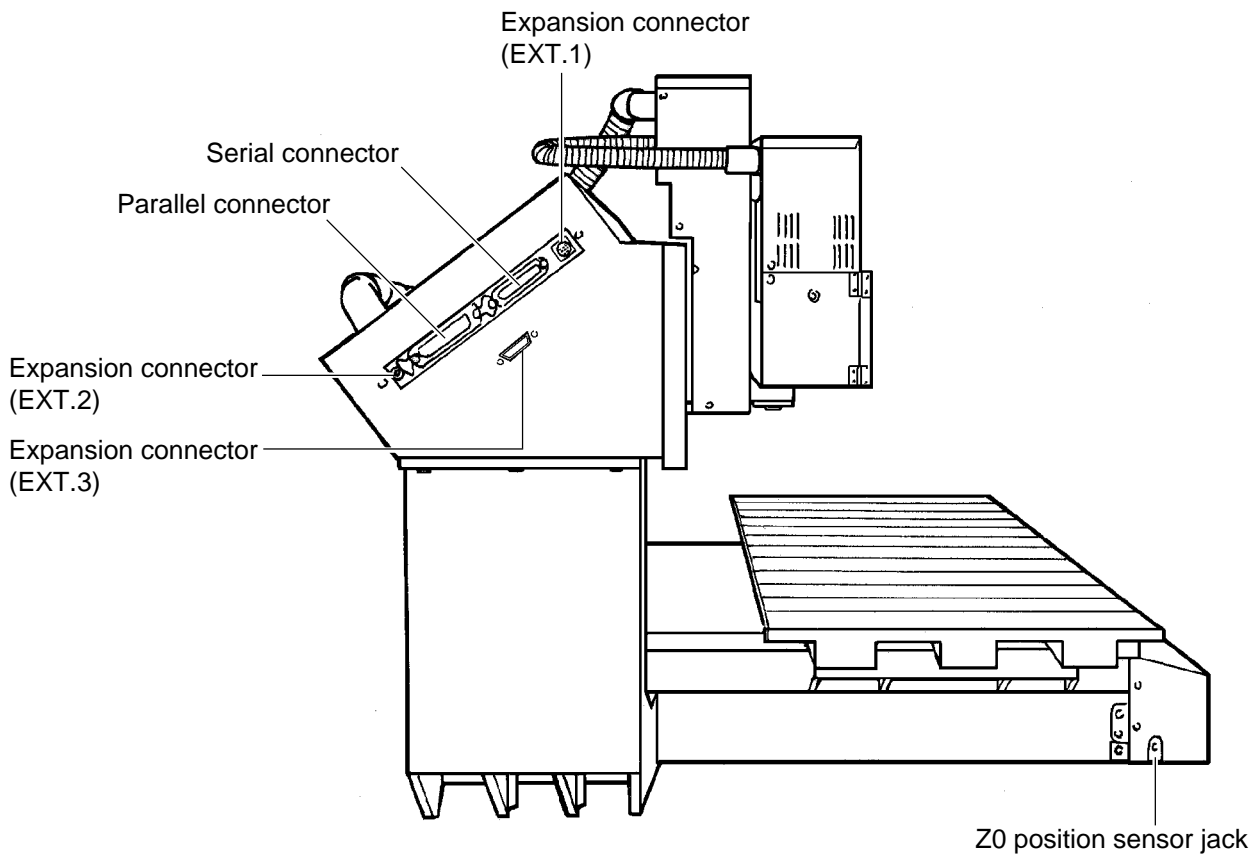

MDX-650 Operation Panel

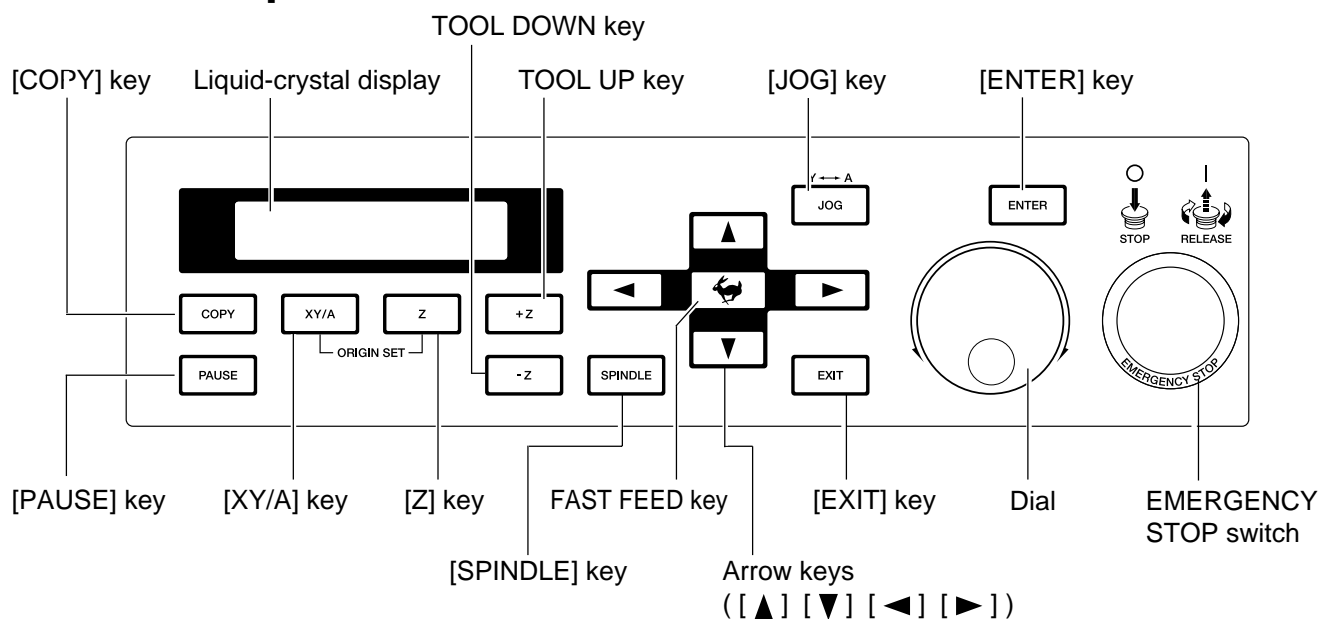

- Dial** This is used to change the selection on the display menu, or during coordinate view to perform jogging of the XY table or tool (Z axis) or to change the speed of the spindle motor.
- [JOG] key** When the display is at coordinate view, this changes selects the item you want to set (jogging of the XY table or tool [Z axis] or spindle-motor speed).When the instruction set is set to NC code, this also selects the displayed coordinate system.
This also switches the Y and A axes when the rotary axis unit (optionally available) is installed.
- [ENTER] key** This is pressed to confirm a selection on the display menu, a value that has been set, or other selections. Use the dial to choose a menu item, then press [ENTER] to go down to the next level. When you want to change a present setting value or selection, make the selection with the dial, then press [ENTER]. The confirmed setting value or selection is shown between angle brackets.
- [EXIT] key** Press this to return to the main menu or to switch between coordinate view and menu view.
- Arrow keys** The [▲] [▼] keys move the XY table forward and backward, and the [◀] [▶] keys move the head to the left and right.
- TOOL UP key** This key makes the cutting tool (blade) move in a positive direction on the Z axis (i.e., upward).
- TOOL DOWN key** This key makes the cutting tool move in a negative direction on the Z axis (i.e., downward).
- FAST FEED key** When pressed at the same time as an arrow key, the TOOL UP key, or the TOOL DOWN key, this makes the movement faster.
- [Z] key** This sets the Z-axis origin point for workpiece coordinates.
- [XY/A] key** This set the X- and Y-axis origin point for workpiece coordinates.
This also sets the A-axis origin point when the rotary axis unit (optionally available) is installed.
- [SPINDLE] key** This starts and stops rotation of the spindle. To start rotation, hold down the key for one second or longer. When the spindle cover is open, the spindle does not rotate.
- [PAUSE] key** When pressed during cutting, operation is paused.
- [COPY] key** This performs cutting again with the data in the data buffer.
- EMERGENCY STOP switch** This switch cuts the power supply and forces the machine to stop, regardless of whether operation is in progress. Press the EMERGENCY STOP switch immediately if dangerous or abnormal operation occurs.

MDX-500 Operation Panel

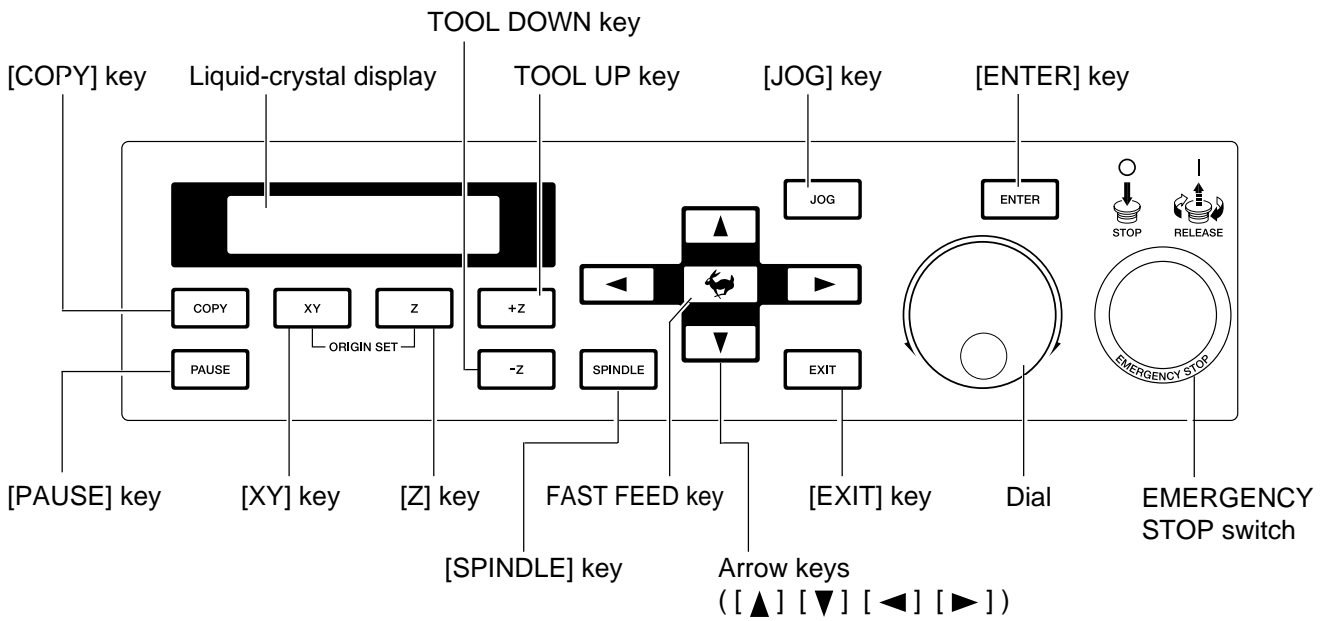

- Dial** This is used to change the selection on the display menu, or during coordinate view to perform jogging of the XY table or tool (Z axis) or to change the speed of the spindle motor.
- [JOG] key** When the display is at coordinate view, this changes selects the item you want to set (jogging of the XY table or tool [Z axis] or spindle-motor speed).
- [ENTER] key** This is pressed to confirm a selection on the display menu, a value that has been set, or other selections. Use the dial to choose a menu item, then press [ENTER] to go down to the next level. When you want to change a present setting value or selection, make the selection with the dial, then press [ENTER]. The confirmed setting value or selection is shown between angle brackets.
- [EXIT] key** Press this to return to the main menu or to switch between coordinate view and menu view.
- Arrow keys** The [▲] [▼] keys move the XY table forward and backward, and the [◀] [▶] keys move the head to the left and right.
- TOOL UP key** This key makes the cutting tool (blade) move in a positive direction on the Z axis (i.e., upward).
- TOOL DOWN key** This key makes the cutting tool move in a negative direction on the Z axis (i.e., downward).
- FAST FEED key** When pressed at the same time as an arrow key, the TOOL UP key, or the TOOL DOWN key, this makes the movement faster.
- [Z] key** This sets the Z-axis origin point for workpiece coordinates.
- [XY] key** This set the X- and Y-axis origin point for workpiece coordinates.
- [SPINDLE] key** This starts and stops rotation of the spindle. To start rotation, hold down the key for one second or longer. When the spindle cover is open, the spindle does not rotate.
- [PAUSE] key** When pressed during cutting, operation is paused.
- [COPY] key** This performs cutting again with the data in the data buffer.
- EMERGENCY STOP switch** This switch cuts the power supply and forces the machine to stop, regardless of whether operation is in progress. Press the EMERGENCY STOP switch immediately if dangerous or abnormal operation occurs.

1-3 Setting Up and Connection Setting

Setting Up

CAUTION



Install on a stable surface.

Failure to do so may result in falling of the unit, leading to injury.

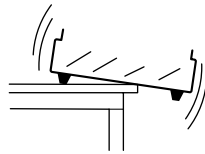

Do not place anything within the moving area of the T-slot table.

The object may bump into the T-slot table and fall, resulting in injury.

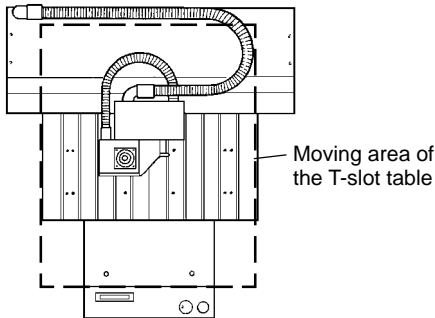

Unpacking, installation, and moving are operations that must be carried out by five or more persons for the MDX-650 and by four or more persons for the MDX-500.

Failure to do so may result in falling of the unit, leading to injury.

(The MDX-650 weighs 120 kg (264.5 lb.), and the MDX-500 weighs 92 kg (202.8 lb.).)

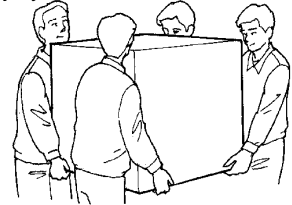

When moving, grasp the aluminum base portion at the bottom portion of the unit, and carry out the operation with five or more persons for the MDX-650 or with four or more persons for the MDX-500.

If grasped by the rear cover, the unit may fall, resulting in injury.

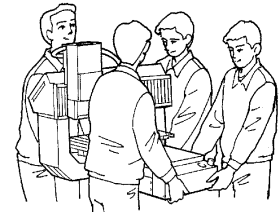

NOTICE

Use within a temperature range of 5 to 40°C (41 to 104°F) and within a humidity range of 35 to 80%.

Do not place any objects on the main unit's head.

When the unit is mounted on a stand with casters, be sure to lock the caster stoppers securely.

To prevent accidents, do not install in any of the following types of areas.

- Avoid use in areas subject to strong electric noise.
- Avoid use in areas subject to high humidity or dust.
- The MDX-650/500 generates heat when used, and should not be installed in an area with poor heat radiation characteristics.
- Do not install in an area subject to strong vibration.

MDX-650

The required dimensions for installation space for the MDX-650 are shown.
 "Maintenance space" is the space needed by a service technician when performing maintenance.

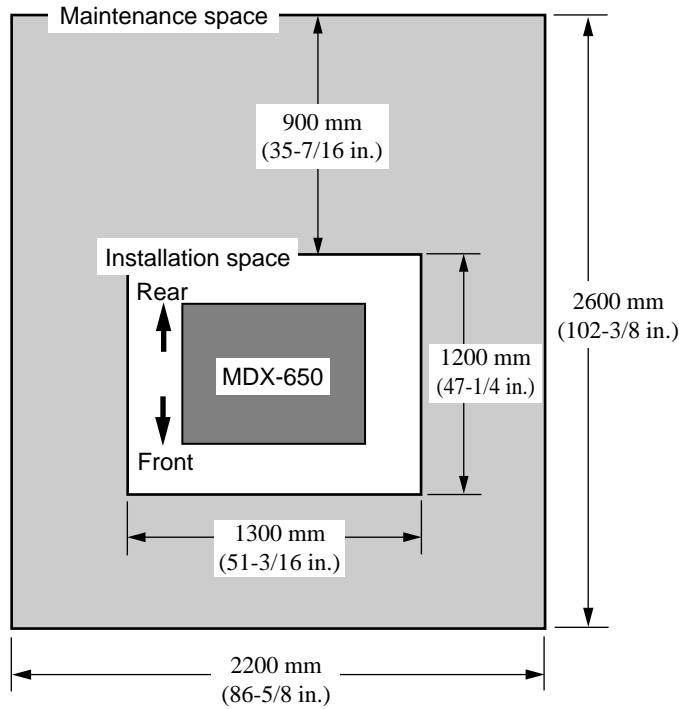

When you are installing the MDX-650 on a stand, use a stand with specifications equivalent to those shown below.

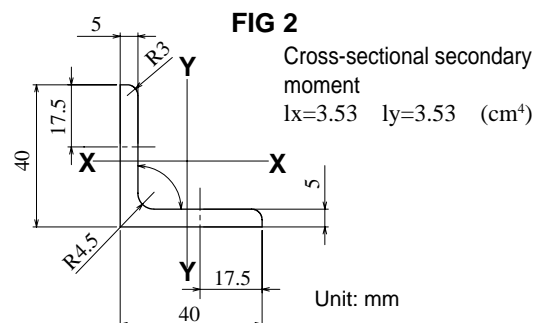
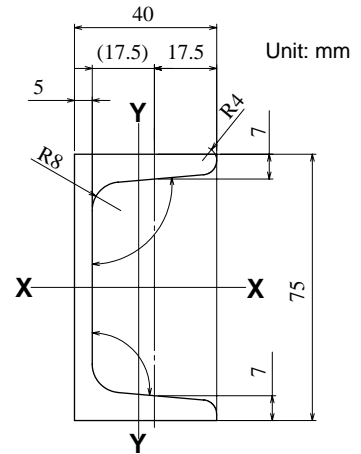
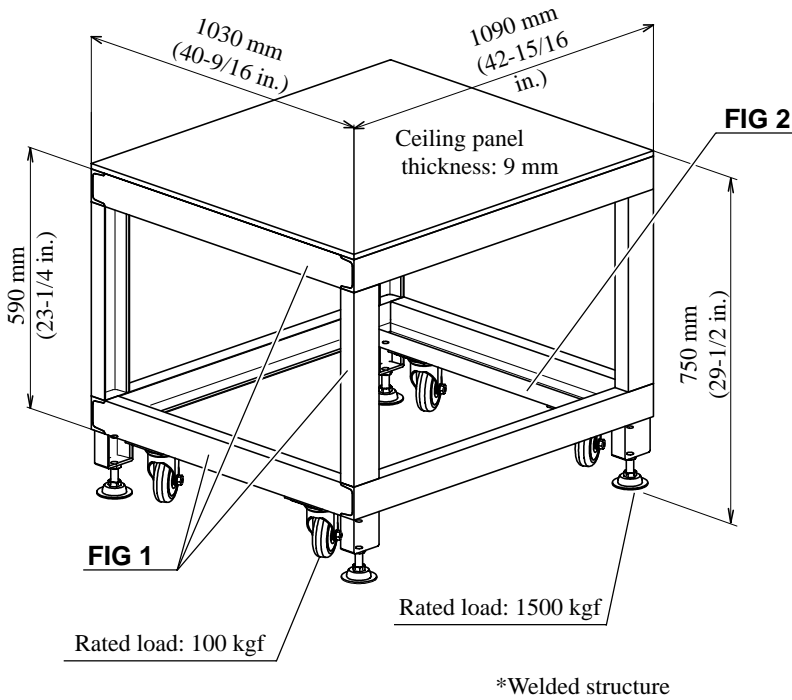

MDX-500

The required dimensions for installation space for the MDX-500 are shown.
 "Maintenance space" is the space needed by a service technician when performing maintenance.

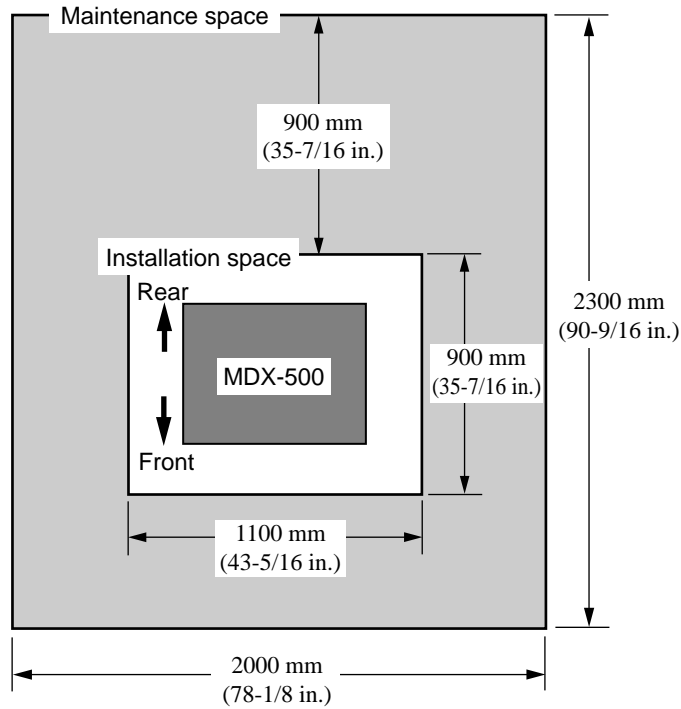

When you are installing the MDX-500 on a stand, use a stand with specifications equivalent to those shown below.

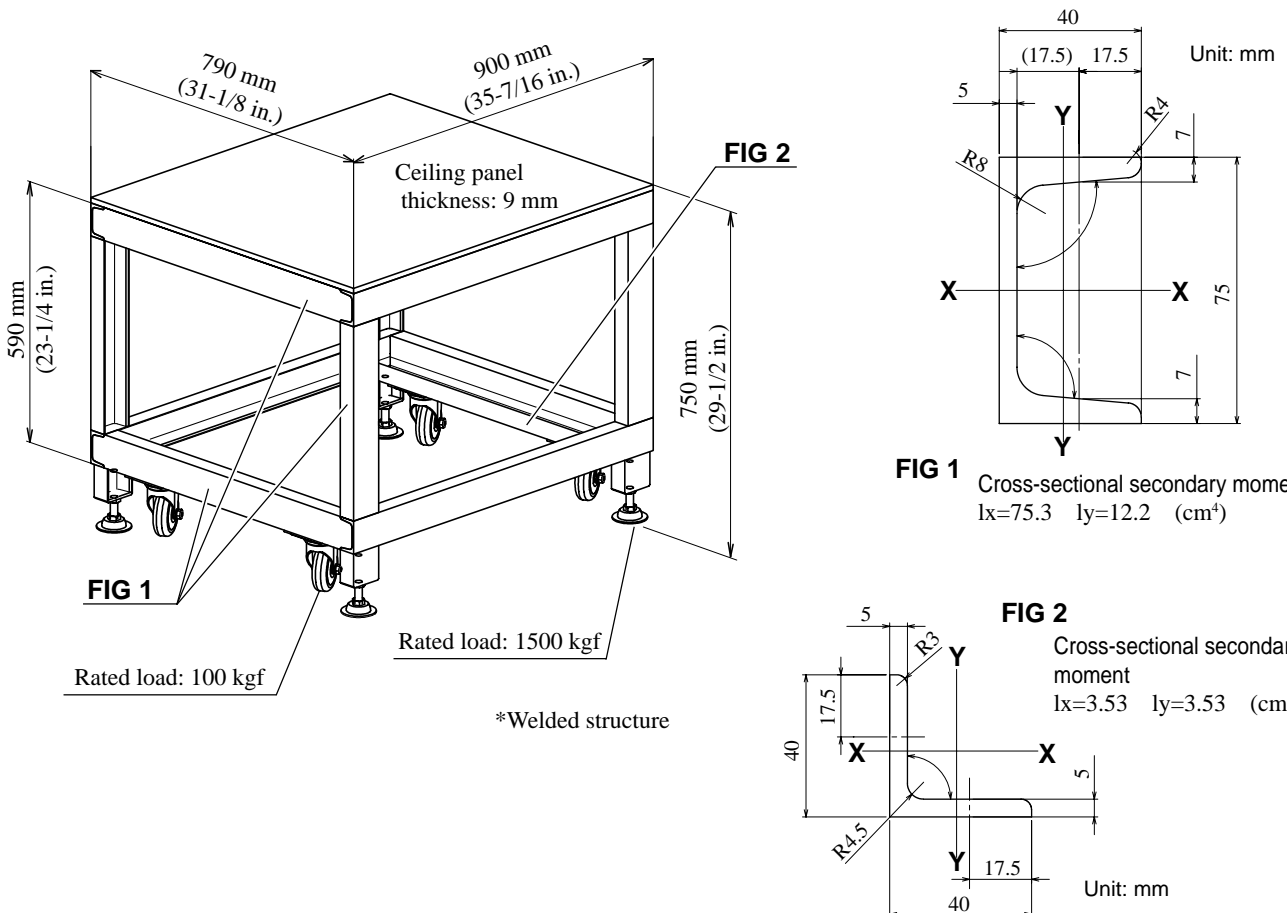

Connection

WARNING



Do not use with any electrical power supply that does not meet the ratings displayed on the unit.

Use with any other power supply may lead to fire or electrocution.



Ground the unit with the ground wire.

Failure to do so may result in risk of electrical shock in the even of a mechanical problem



Use only with the power cord included with this product.

Use with other than the included power cord may lead to fire or electrocution.

CAUTION



Do not connect the power cord with other electrical loads on a single electrical outlet.

Doing so may generate heat and cause fire.

NOTICE

Be sure that the power to both the computer and the main unit is switched off when connecting the cable.

Securely connect the power cord, computer I/O cable and so on so that they will not be unplugged and cause failure during operation. Doing so may lead to faulty operation or breakdown.

Right side

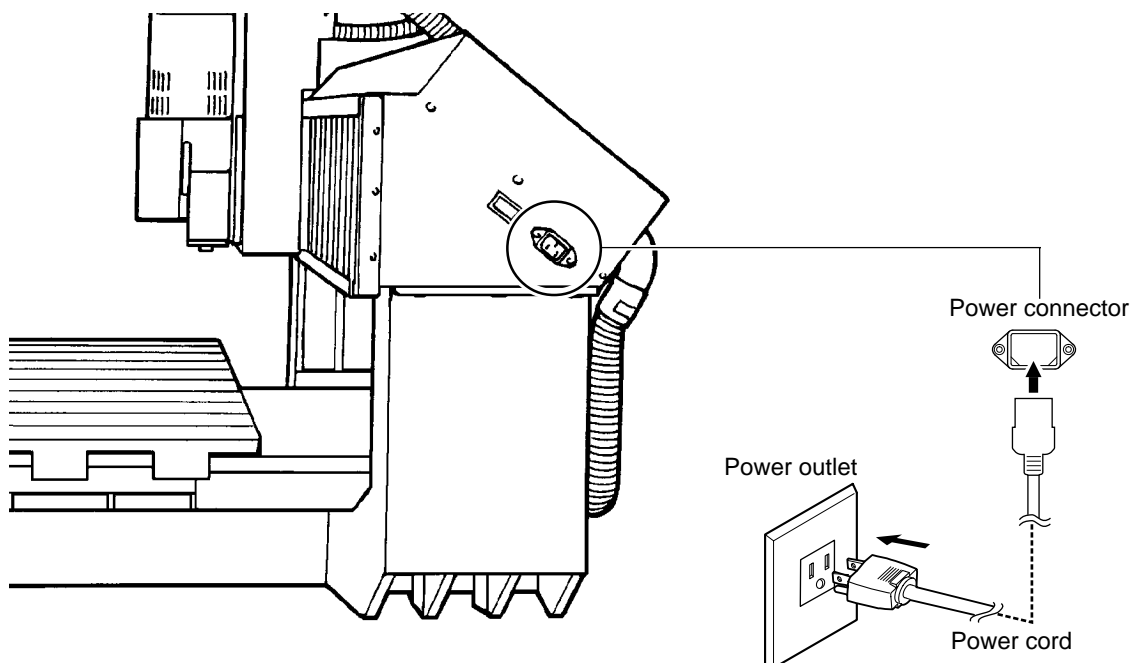

*Be sure the machine's power is turned off before you insert or remove the key connector.

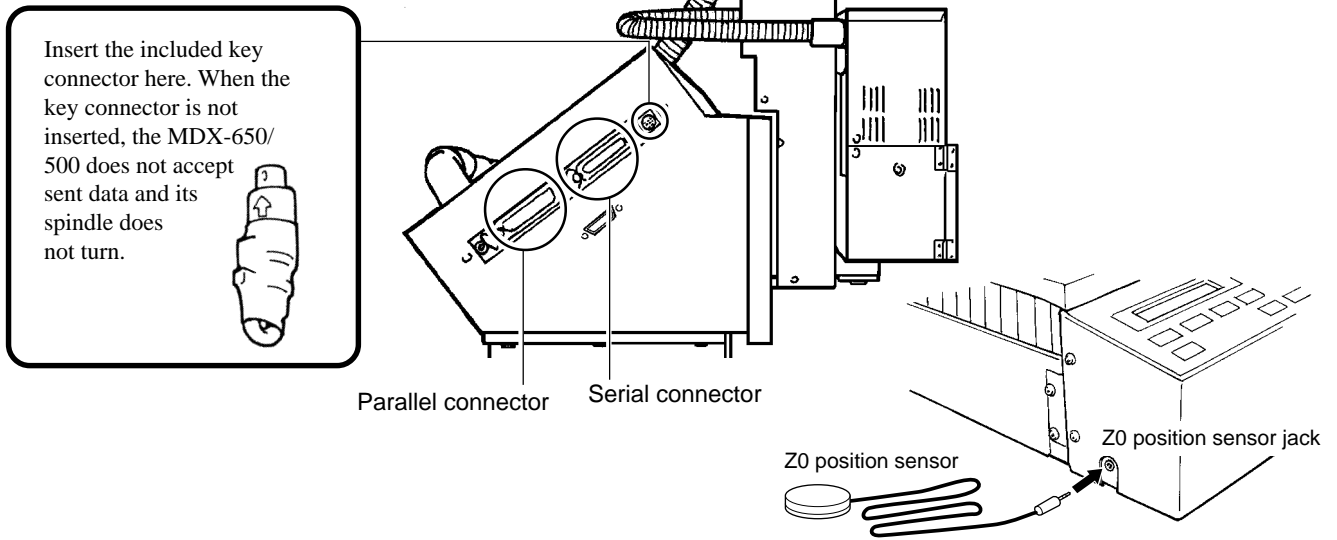

For IBM PC or PC compatibles

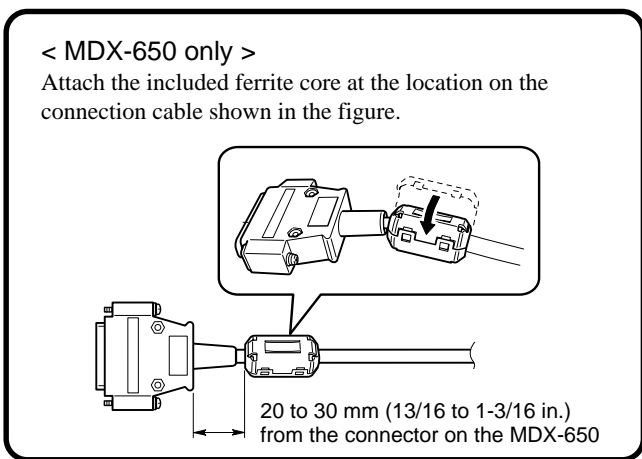
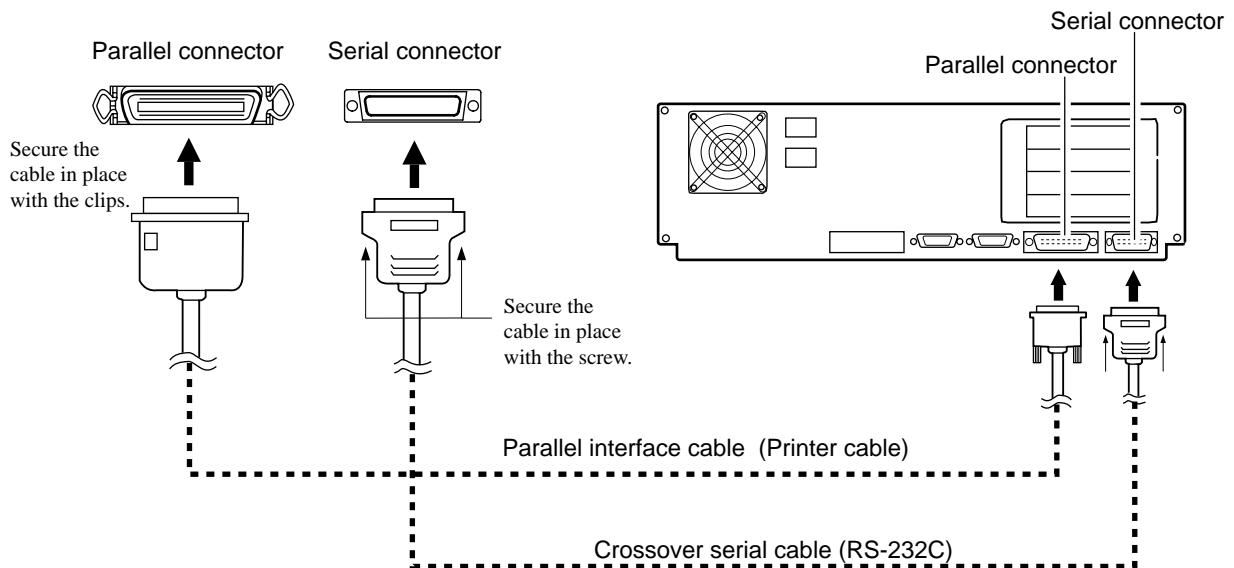

* Cables are available separately. One which you are sure matches the model of computer being used should be selected.

1-4 Description of the Spindle Area

About the Spindle Cover

NOTICE When a cutting operation is in progress, do not open the spindle cover. Opening the spindle cover during operation causes an emergency stop. Data during operation becomes invalid, and cutting cannot be continued.

The MDX-650/500 has a cover on the spindle area. Open the spindle cover to perform such tasks as installing or changing tools. Because of the danger posed by accidental operation while the hands are in contact with the rotating portion, the unit does not operate while the spindle cover is open. Not only does the spindle motor not rotate, but the head and the T-slot table also cannot be moved.

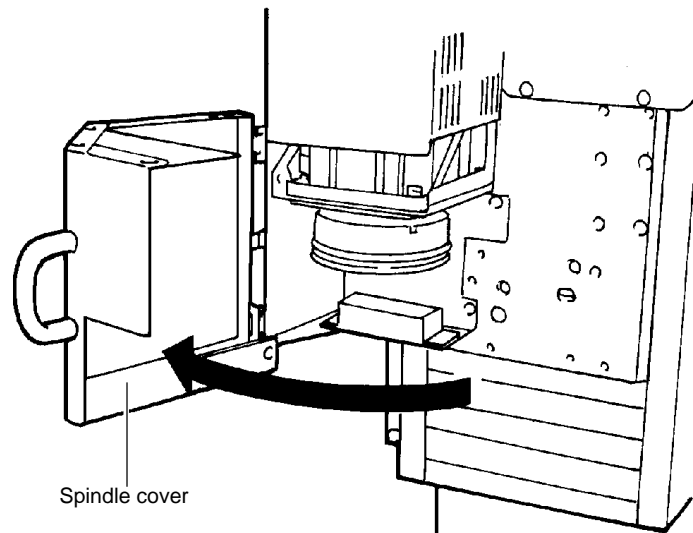

High-torque Spindle and High-speed Spindle

The MDX-650/500 can use either of two types of spindle heads: a high-torque spindle or a high-speed spindle (spindle heads are sold separately).

The setting for the type of spindle installed (high-torque or high-speed) must be made on the MDX-650/500. (Refer to "1-6 Choosing the Spindle Type.")

High-torque Spindle

This spindle head is designed for torque.

Speed is from 3,000 to 12,000 rpm.

It is mainly suited to cutting using an end mill (modeling).

Different ones for the MDX-650 and for the MDX-500 are available.

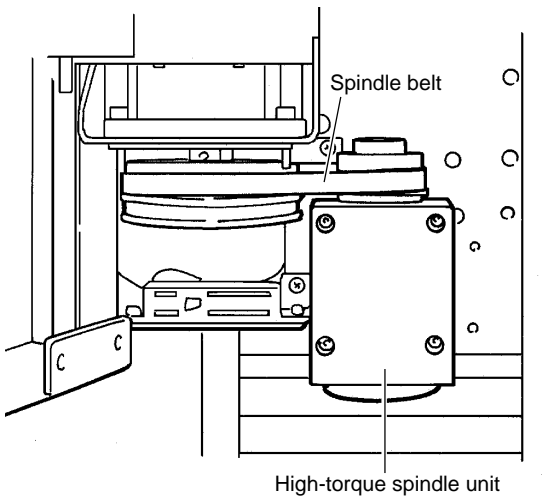

High-speed Spindle

This spindle head is designed for speeds from 5,000 to 20,000 rpm.

Torque is not as high as the high-torque spindle.

It is mainly suited to cutting using an engraving tool.

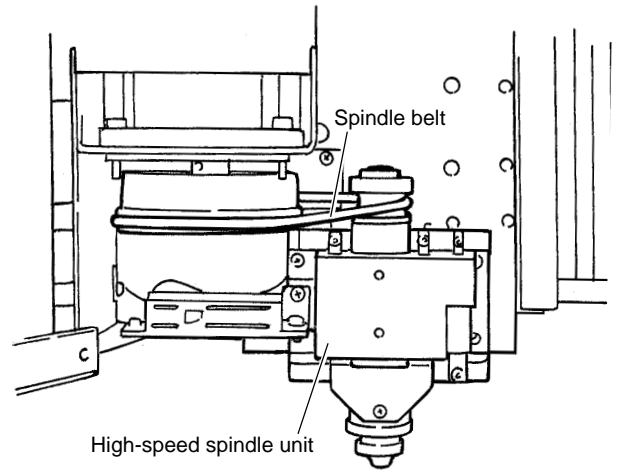

Installable Optional Items for Different Spindles

	Collet	Cutting Tool	Vacuum adapter
High-torque Spindle *ZS-650T (For the MDX-650) *ZS-500T (For the MDX-500)	ø6 mm Standardly included with the spindle	ø6 mm End mill	*ZAD-500T
	ø10, ø8, ø6.35, ø5, ø4, ø3.2, ø3 mm *ZC-500T (Collet set)	ø10, ø8, ø6.35, ø5, ø4, ø3.2, ø3 mm End mill	
	ø6.35, ø4.36 mm *ZC-500TE (Collet and holder set)	ø6.35, ø4.36 mm Engraving cutter	
High-speed Spindle *ZS-500SH	ø4.36 mm Standardly included with the spindle	ø4.36 mm Engraving cutter	*ZAD-500S
	ø6, ø5, ø4, ø3 mm *ZC-23 (Collet set)	ø6, ø5, ø4, ø3 mm End mill	
	ø6.35 mm *ZC-23-6.35	ø6.35 mm End mill	

* Indicates option part number. For tool part numbers, see the supply-part catalog.

High-torque Spindle (Optional) Set

Make sure the following items are included with the high-torque spindle (ZS-650T/ZS-500T).

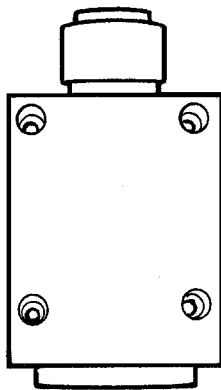

Spindle unit

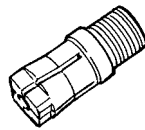

Collet

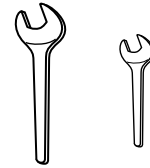

Wrenches
(24 mm (15/16 in.),
13 mm (1/2 in.))



Screws: 4

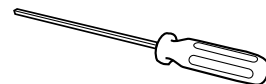

Hexagonal screw driver

Installing the High-torque Spindle (ZS-650T/ZS-500T)

CAUTION



Fasten the spindle, tool, and material securely in place.

Otherwise they may come loose during cutting, resulting in injury.

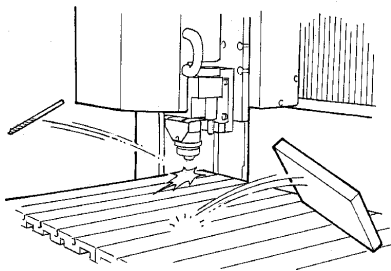

- 1** Align the pin on the back of the spindle unit with the pin-hole on the slider, and support it with your hand.

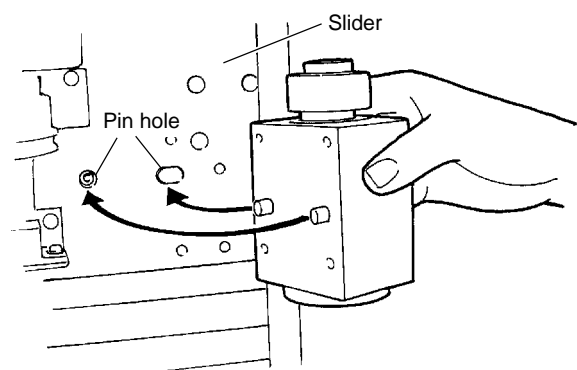

- 2** Insert the screw at the location shown in the figure, then tighten using the included hexagonal screwdriver.

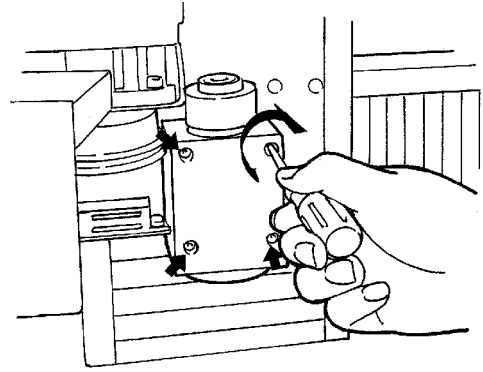

- 3** Pass the belt through under the motor pulley and engage on the spindle pulley.

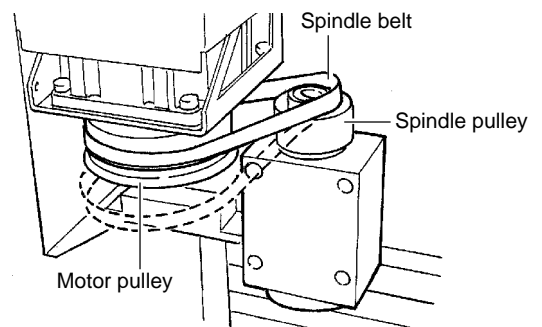

- 4** While pressing down on the belt engaged on the spindle pulley, turn the motor pulley in the direction of the arrow to attach the belt.

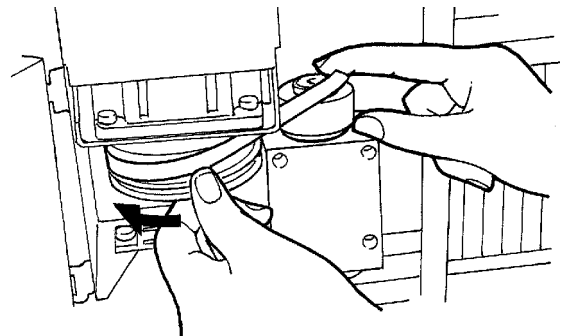

- 5** Turn the motor pulley several times so as to position the belt on the motor pulley and spindle pulley as shown in the figure.

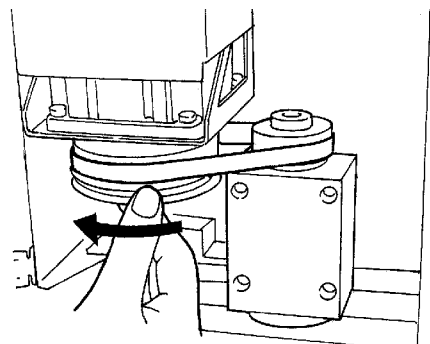

Installing the Tool

CAUTION



Do not touch the tip of the blade with your fingers.

Doing so may result in injury.



Fasten the spindle, tool, and material securely in place.

Otherwise they may come loose during cutting, resulting in injury.

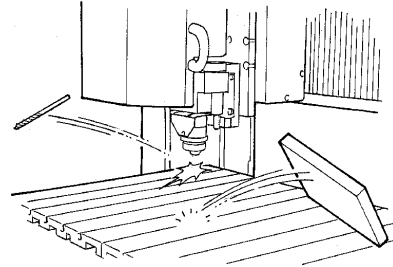

Do not touch the tool immediately after cutting operating stops.

The tool may have become hot due to friction heat and may cause burns if touched.

NOTICE

Use the correct tool for the material to be cut and the cutting method.

Do not attach the collet without the end mill and tighten with the wrench. Doing so may make it impossible to install an end mill the next time used.

When installing an end mill, detach the blade holder. If you try to perform machining with the blade holder installed, the vibration may make it come loose and fall off.

Be sure to use the wrench included with the unit. Using a wrench other than included one may result in overtightening, making it impossible to remove the collet or damaging the spindle.

Use caution to prevent the cutting tool from falling out, otherwise the cutting tool may be damaged.

Be careful not to drop the collet.

Doing so may cause the collet to deform or break, making it impossible to install a tool.

Installing an End Mill

Install a collet that matches the shank diameter of the end mill. The combination of end mill and collet is correct if the diameter of the end mill just fits in the hole in the collet.

The collet included with the high-torque spindle has a diameter of 6 mm. When using an end mill having a diameter other than 6 mm (i.e., a diameter of 10, 8, 6.35, 5, 4, 3.2, or 3 mm), the optionally available collet set (ZC-500T) is required.

- 1 Insert the end mill into the collet.

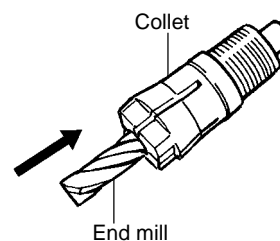

- 2 Insert the assembly from step 1 into the lower part of the spindle. While supporting the end mill with your hand to keep it from falling, rotate the spindle pulley to secure in place.

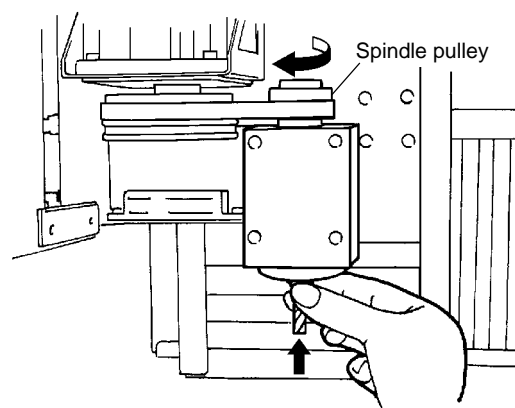

- 3 Use the included wrenches to tighten the spindle pulley and collet (150 to 200 kgf-cm).

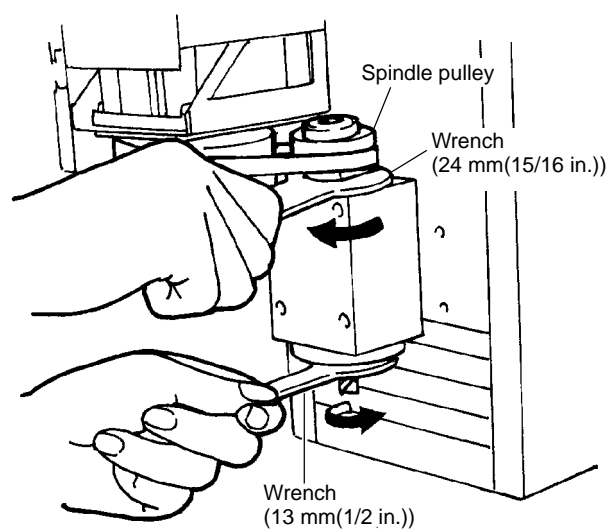

Installing an Engraving Tool

Install a cutter holder and collet which are suitable for the cutter to be used. The combination of end mill and collet is correct if the diameter of the end mill just fits in the hole in the collet.

Using an engraving tool with the high-torque spindle requires the optionally available collet and blade-holder set (ZC-500TE).

- 1** Install the blade holder and the collet.

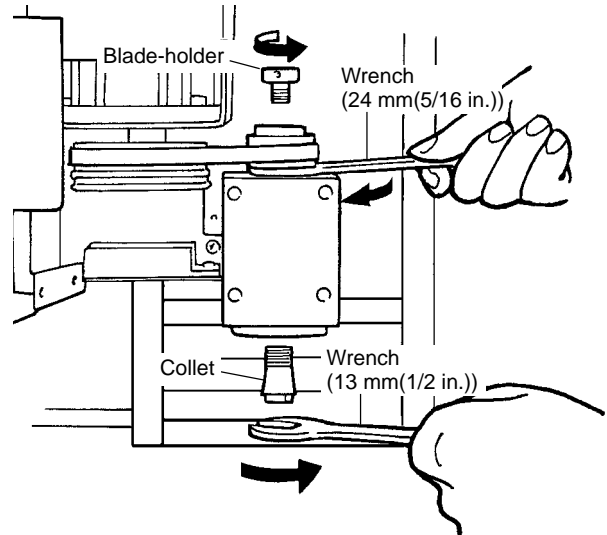

- 2** Use the arrow keys and the tool-down key to position the tip of the head approximately 20 mm (13/16 in.) from the surface of the workpiece.

* When attempting to move the head, first close the spindle cover.

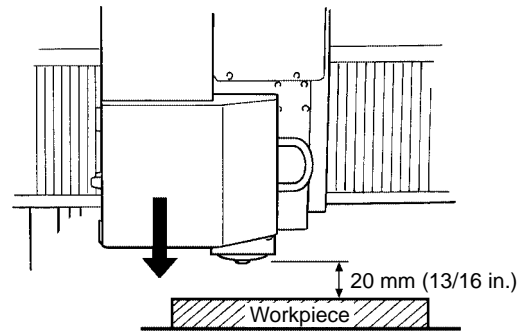

- 3** Insert the cutter into the hole in the cutter holder and position the tip so that it gently touches the surface of the workpiece. Use the hexagonal screwdriver included with the ZC-500TE to tighten the tool retaining screw.

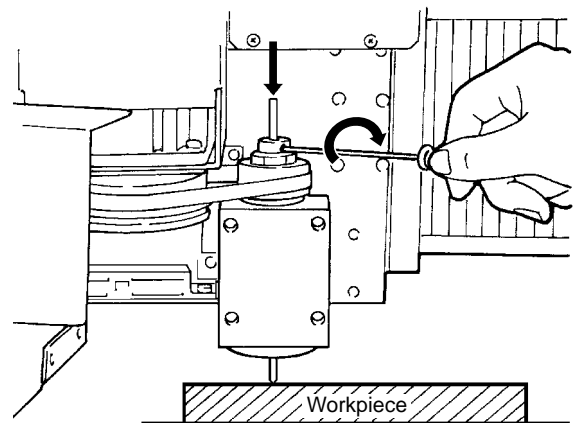

- 4** Use the operation panel to set the Z-axis origin point. The Z-axis origin is the reference point for raising and lowering the spindle. For information on how to make the setting, refer to User's Manual 2 or User's Manual 3, depending on the command set you're using.

Attaching the Brush Adapter for Chip Cleaning for the High-torque Spindle (ZAD-500T)

⚠ CAUTION



Use a commercially available brush to remove metal cuttings.

Attempting to use a vacuum cleaner to take up metal cuttings may cause fire in the vacuum cleaner.



NOTICE

Use a vacuum cleaner that lets you adjust the amount of suction and is equipped with an overload protector.

Always allow a minimum gap of 30 cm (11-13/16 in.) on the side where the vacuum hose exits. The vacuum hose must have sufficient space in which to move. When the vacuum hose cannot move smoothly, it can cause malfunctions or errors in operation.



When the fitting diameters do not match or when the vacuum duct cannot be inserted into the suction opening of the vacuum cleaner, use strong commercial tape (cloth or electrical) to join the fittings. The duct diameter of the ZAD-500T is 32 mm (1-5/16 in.).

Attaching the optionally available brush adapter for chip cleaning (ZAD-500T) to the high-torque spindle (ZS-650T/ZS-500T) makes it possible to take up cutting dust with your vacuum cleaner as you perform cutting. This is mainly of use when performing cutting using an end mill (modeling).

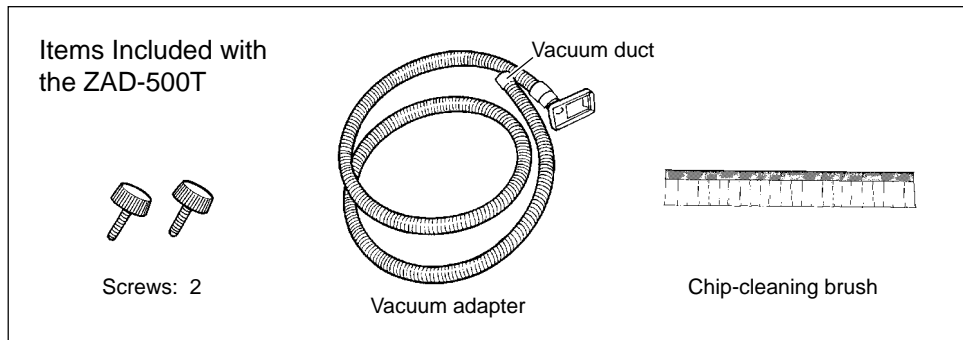

- 1 Fasten the touch fastener to attach the chip-cleaning brush to the brush adapter for chip cleaning.

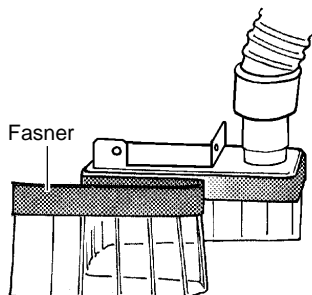

* Even when the brush adapter for chip cleaning is installed on the machine, you can change the tool by unfastening the touch fastener.

- 2 Install the brush adapter for chip cleaning on the machine's spindle portion.

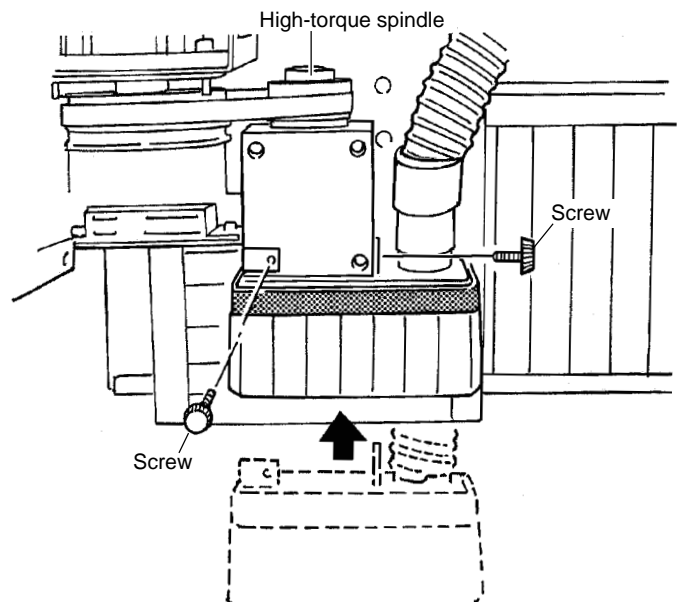

High-speed Spindle (Optional) Set

Make sure the following items are included with the high-speed spindle (ZS-500SH).

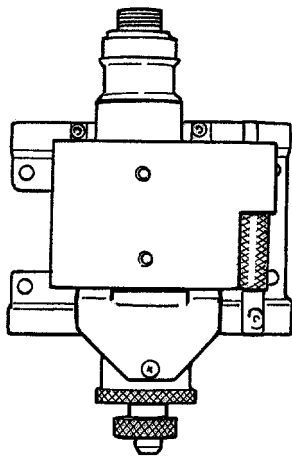

Spindle unit

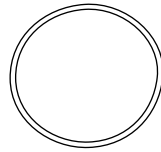

Spindle belt

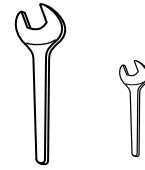

Wrenches
(24 mm (15/16 in.),
10 mm (3/8 in.))

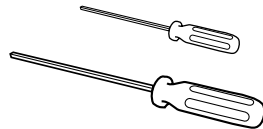

Hexagonal screw drivers



Screws: 4



Collet
(4.36 mm (3/16 in.))

◀ These are installed
on the spindle unit. ▶



Cutter holder
(4.36 mm (3/16 in.))

Installing the High-speed Spindle (ZS-500SH)

⚠ CAUTION



Fasten the spindle, tool, and material securely in place.
Otherwise they may come loose during cutting, resulting in injury.

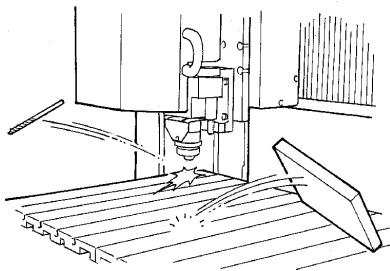

- 1 Align the pin on the back of the spindle unit with the pin-hole on the slider, and support it with your hand.

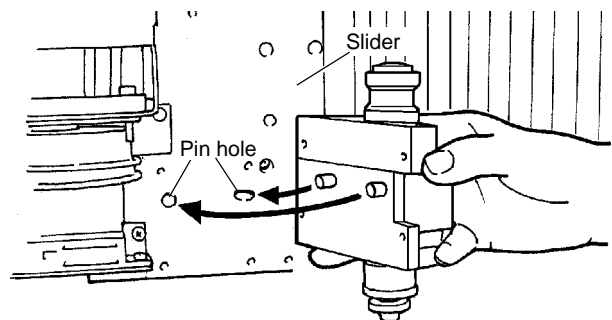

- 2** Insert the screw at the location shown in the figure, then tighten using the included hexagonal screwdriver.

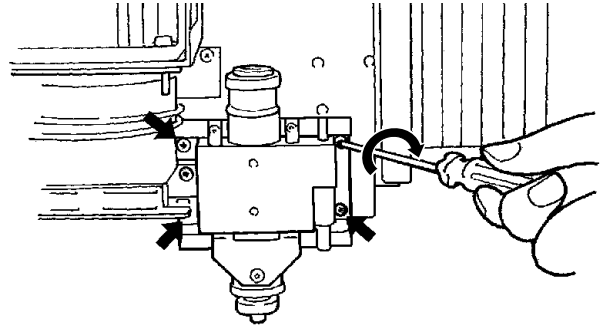

- 3** Engage the belt in the groove on the motor pulley then pull by hand to hand it on the spindle pulley.

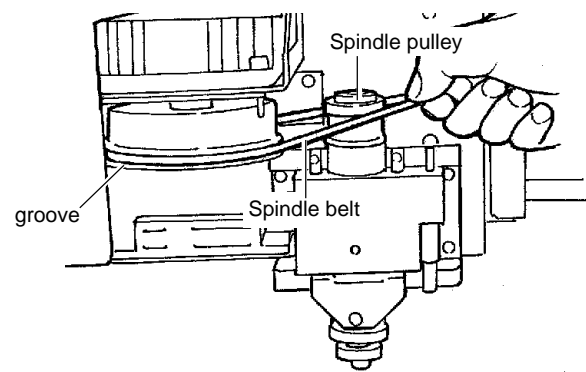

Installing the Tool

CAUTION



Do not touch the tip of the blade with your fingers.

Doing so may result in injury.



Fasten the spindle, tool, and material securely in place.

Otherwise they may come loose during cutting, resulting in injury.

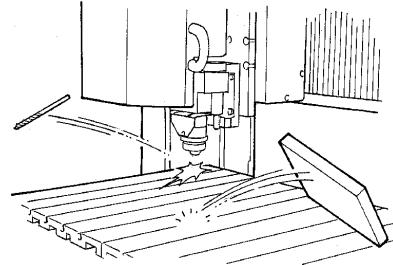

Do not touch the tool immediately after cutting operating stops.

The tool may have become hot due to friction heat and may cause burns if touched.

NOTICE

Use the correct tool for the material to be cut and the cutting method.

When installing an end mill, attach only the collet without the tool, and do not tighten using the wrench. Doing so may make it impossible to install a tool the next time used.

When installing an end mill, detach the blade holder. If you try to perform machining with the blade holder installed, the vibration may make it come loose and fall off.

Be sure to use the wrench included with the unit. Using a wrench other than included one may result in overtightening, making it impossible to remove the collet or damaging the spindle.

Use caution to prevent the cutting tool from falling out, otherwise the cutting tool may be damaged.

Installing an Engraving Tool

Install a cutter holder and collet which are suitable for the cutter to be used. The combination of end mill and collet is correct if the diameter of the end mill just fits in the hole in the collet.

The collet and blade holder included with the high-speed spindle has a diameter of 4.36 mm.

Install the blade holder and the collet.

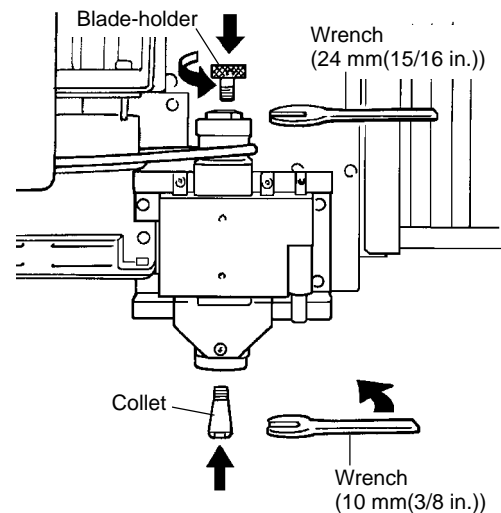

*When Using the Depth Regulator Nose

Using the depth regulator nose makes it possible to engrave workpiece of nonuniform thickness at same depth.

(Because engraving is performed while the tip of the depth regulator nose is in contact with the workpiece, the surface of the workpiece may be damaged.)

- 1 Rotate the depth regulator nose in the direction of arrow 2 in the figure to tighten it completely.

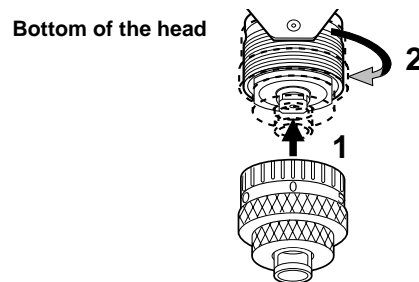

- 2 This determines the engraving depth (cutting-in amount). The scale on the micrometer dial assembly has 25 grooves, with one groove corresponding to an engraving depth of 0.0254 mm (0.001 in.). (One full turn of the scale corresponds to an engraving depth of 0.635 mm (0.025 in.)) Rotate the scale in the direction of the arrow shown in the figure by an amount equal to or greater than the engraving depth.

For example, when engraving to a depth of 0.5 mm (0.0197 in.), the scale should be rotated by 20 grooves (approximately one full turn). For engraving at a depth of 1.5 mm (0.0591 in.), rotate the scale by 59 grooves (approximately three turns).

Bottom of the head

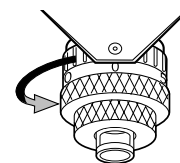

- 3 Turn the nut in the direction of the arrow to loosen completely.

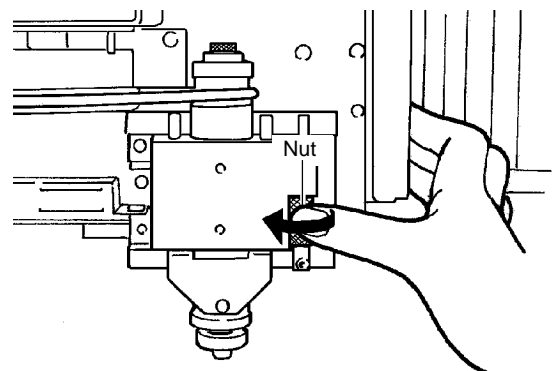

- 4** Use the arrow keys to position the head over the workpiece.
- * When attempting to move the head, first close the spindle cover.

- 5** Press the TOOL DOWN key to bring the depth regulator nose in contact with the surface of the workpiece.
- * When attempting to move the head, first close the spindle cover.

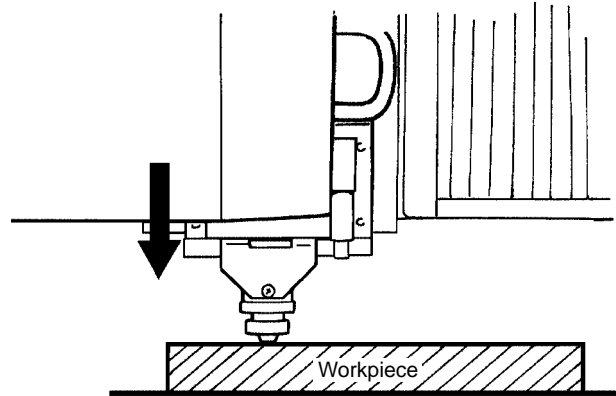

If the depth regulator nose does not reach the surface of the workpiece even when the tool down (-Z) key is held down, rotate the micrometer dial in the direction shown by the arrow in the figure to extend the tip of the depth regulator nose to the workpiece surface.

If the tip of the depth regulator nose doesn't reach the surface of the workpiece because the workpiece is too thin, place a board between the workpiece and the table.

Alternatively, use the optionally available spacer for the T-slot table (ZA-600/500 series) to raise the height of the table.

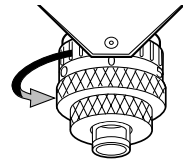

- 6** Set the Z-axis origin point at the location you set in step 5. The Z-axis origin is the reference point for raising and lowering the spindle.
- For information on how to make the setting, refer to User's Manual 2 or User's Manual 3, depending on the command set you're using.

- 7** Insert the cutter into the hole in the cutter holder, and use the hexagonal screwdriver (small) that comes with the machine to tighten the cutter mounting screw.

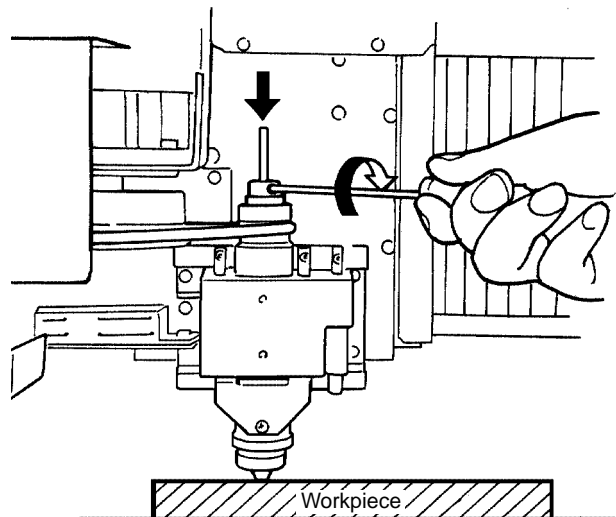

- 8** Raise the spindle with the tool up (+Z) key.
- * When attempting to move the head, first close the spindle cover.

- 9** Rotate the dial in the direction of the arrow shown in the figure to extend the cutter to the engraving depth (cutting-in amount).
Move the cutter out just enough for the necessary engraving depth.
The lines printed on the dial indicate 0.0254 mm (0.001 in.) for each mark. For instance, to set a cutting depth of 0.5 mm (0.0197 in.), rotate an 20 mark portion.

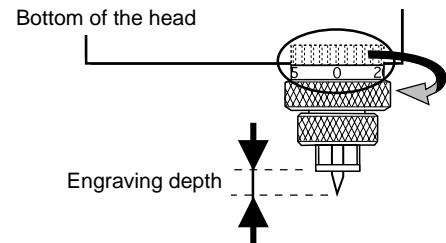

- 10** Use a program or the operation panel on the MDX-650/500 to set the tool-down position. Set this at a cutting-in amount about 2 to 3 mm deeper than the cutting-in amount set using the micrometer dial (the actual cutting-in amount).
Setting a cutting-in amount that corresponds to the difference in height between the highest and lowest locations on the workpiece allows the tip of the depth regulator nose to be constantly pressed against the surface of the workpiece and enables engraving at a uniform depth.

* The spindle stroke due to the nut is approximately 5 mm (3/16 in.).
It is not possible to absorb differences in height greater than 5 mm (3/16 in.).

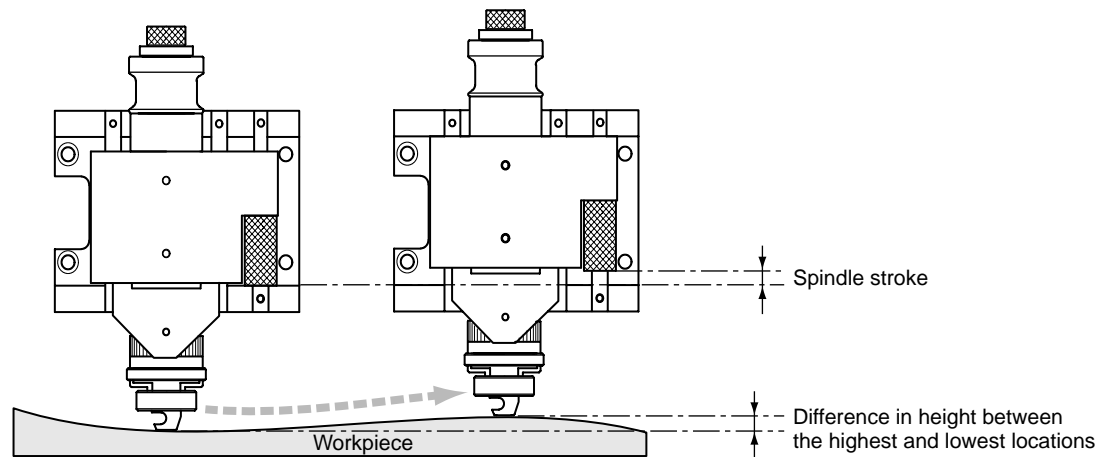

***When Not Using the Depth Regulator Nose**



If you do not use the depth regulator nose, take a table workpiece made of ABS plastic about 10 mm (3/8 in.) thick, secure it in place on the included table, and perform surface leveling. By using this as the table surface, you can carry out engraving at a uniform depth.

- 1** Turn the nut in the direction of the arrow to tighten it securely.

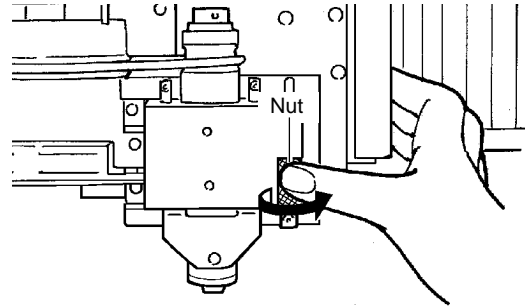

- 2** Press the arrow keys and the tool down (-Z) key to move the tip of the head to a position close to the surface of the workpiece

* When attempting to move the head, first close the spindle cover.

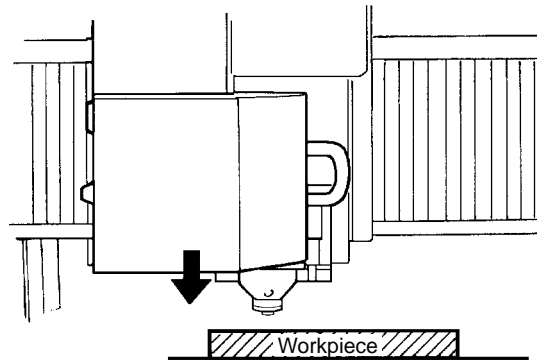

- 3** Insert the cutter into the hole in the cutter holder and position the tip so that it gently touches the surface of the workpiece. Use the hexagonal screw driver included with the ZC-500TE to tighten the screw.

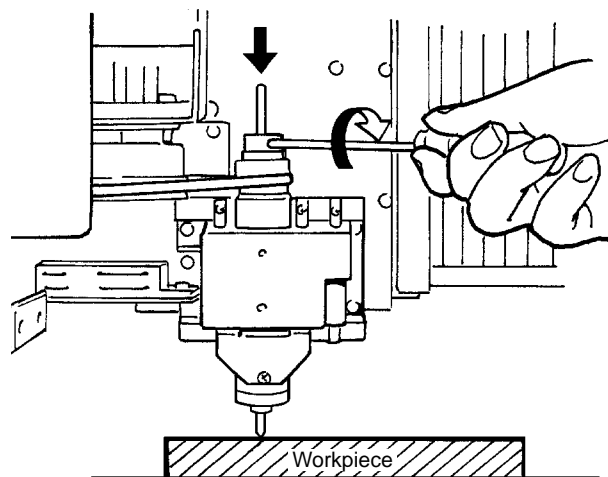

- 4** Use the operation panel to set the Z-axis origin point. The Z-axis origin is the reference point for raising and lowering the spindle.
For information on how to make the setting, refer to User's Manual 2 or User's Manual 3, depending on the command set you're using.

Installing an End Mill

Install a collet that matches the shank diameter of the end mill. The combination of end mill and collet is correct if the diameter of the end mill just fits in the hole in the collet.

Using an end mill with the high-speed spindle requires the optionally available collet set (ZC-23) or collet (ZC-23-6.35).

- 1 Insert the end mill into the collet.

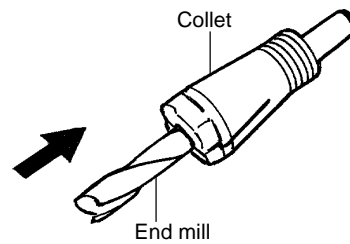

- 2 Insert the assembly from step 1 into the lower part of the spindle, and turn the collet to secure it in place and keep the end mill from falling out.

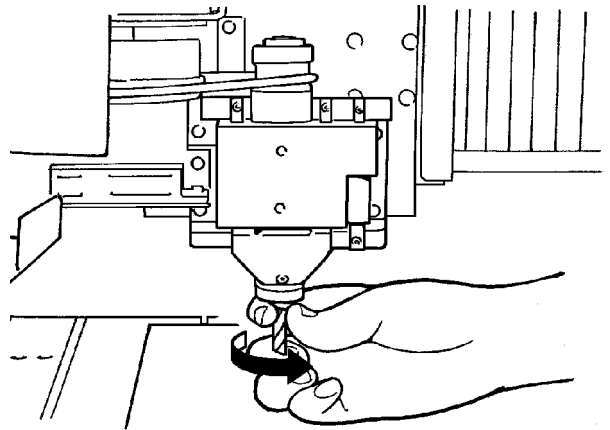

- 3 Use the included wrenches to tighten the spindle pulley and collet (150 to 200 kgf-cm).

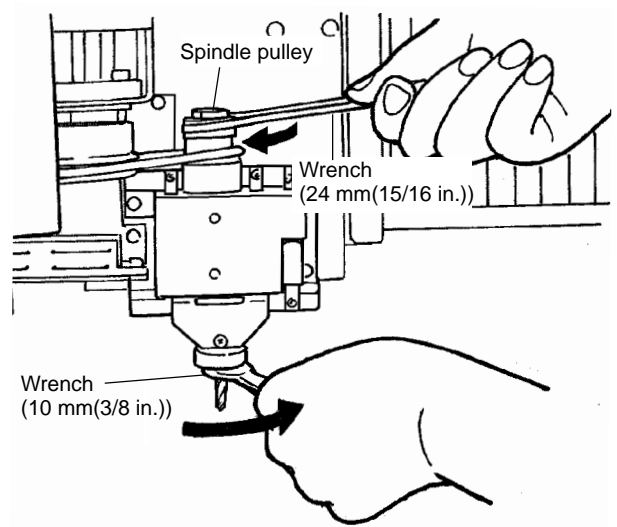

Attaching the Brush Adapter for Chip Cleaning for the High-speed Spindle (ZAD-500S)

⚠ CAUTION



Use a commercially available brush to remove metal cuttings.

Attempting to use a vacuum cleaner to take up metal cuttings may cause fire in the vacuum cleaner.



NOTICE

Use a vacuum cleaner that lets you adjust the amount of suction and is equipped with an overload protector.

Always allow a minimum gap of 30 cm (11-13/16 in.) on the side where the vacuum hose exits. The vacuum hose must have sufficient space in which to move. When the vacuum hose cannot move smoothly, it can cause malfunctions or errors in operation.



When the fitting diameters do not match or when the vacuum duct cannot be inserted into the suction opening of the vacuum cleaner, use strong commercial tape (cloth or electrical) to join the fittings. The duct diameter of the ZAD-500T is 32 mm (1-5/16 in.).

Attaching the optionally available brush adapter for chip cleaning (ZAD-500S) to the high-speed spindle (ZS-500SH) makes it possible to take up cutting dust with your vacuum cleaner as you perform cutting. This is mainly of use when performing cutting using an engraving tool.

Items Included with the ZAD-500S

Hooks: 2

Vacuum hose

Vacuum duct

Vacuum adapter

1) Take off the cap and insert the hook.

2) Secure the vacuum hose in place.

1

Tighten

2

1) Take off the cap and insert the hook.

2) Secure the vacuum hose in place.

1-5 Selection of the Command Set

On the MDX-650/500, the first thing to do is to select the command set to use.

To perform output from the Windows program through the driver, choose "RML-1."

The driver is installed from the included Roland Software Package. For more information on how to install it, take a look at "User's Manual 2_Cutting Using the Included Software."

Selecting the Command Set on the MDX-650/500

Immediately after switching on the power, use the display to choose either RML-1 or NC code. Follow the steps below to choose the command set.

Once the command set has been selected, it can only be changed by switching the power off and on again. When you turn on the power, the display shows the command last selected in blinking text. If you don't want to change this command, press the [ENTER] key.

1

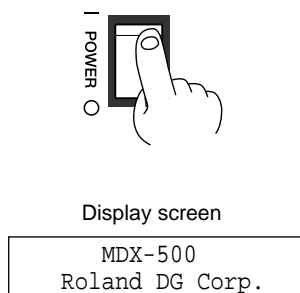

2

Turn the dial to move the arrow to the command set to use, then press the [ENTER] key.

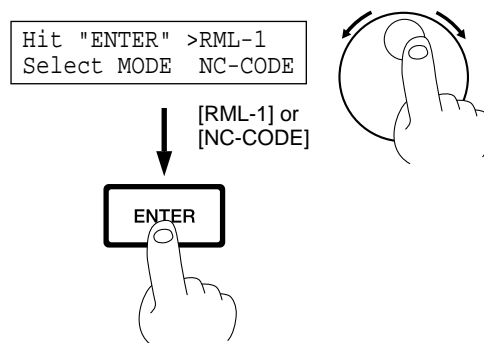

The method of operation during cutting differs according to the selected command set. If you selected RML-1, see "User's Manual 2 -- Cutting Using the Included Software." If you selected NC code, see "User's Manual 3 -- Cutting Using NC Codes."

1-6 Choosing the Spindle Type

This sets the type of the installed spindle to MDX-650/500.

If a high-torque spindle is installed, choose [HIGH TORQUE]. If a high-speed spindle is installed, choose [HIGH SPEED]. An incorrect selection may result in insufficient power to the motor and make normal cutting impossible, or conversely may apply power beyond the rated capacity to the motor and cause an error to be displayed during cutting.

- 1 If the display shows coordinates, press the [ENTER] key to display the main menu.

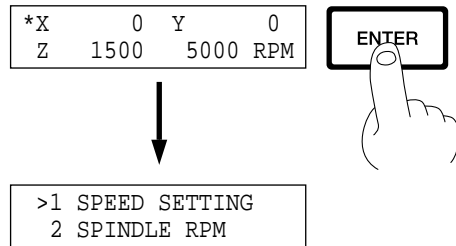

- 2 Turn the dial to move the arrow to [OTHERS], then press the [ENTER] key.

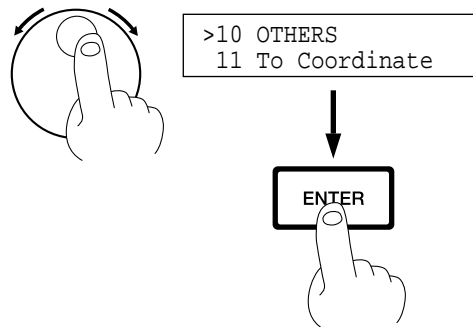

- 3 Turn the dial to move the arrow to [SPINDLE UNIT], then press the [ENTER] key.

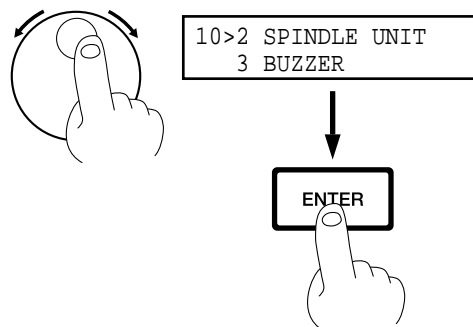

- 4 Turn the dial to move the arrow to [HIGH TORQUE] or [HIGH SPEED], then press the [ENTER] key. The selected mode is enclosed in angle brackets.

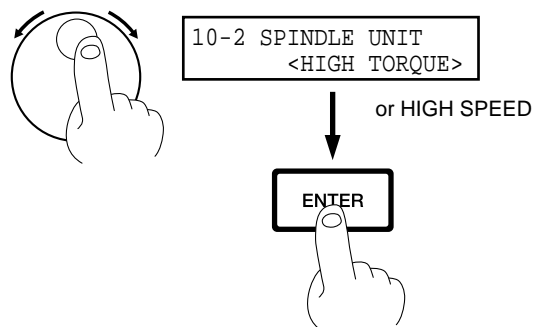

* To go back to the main menu, press the [EXIT] key several times.

1-7 The Cutting Area

MDX-650

The maximum cutting area of the MDX-650 is 650 mm x 450 mm x 155 mm (25-9/16 in. x 17-11/16 in. x 6-1/16 in.). If you selected RML-1 as the command set, then when converted to coordinate values (step size: 1/100 mm), (x, y, z) = (50,000, 33,000, 10,500). The actual cutting area of the MDX-650 differs according to the type of spindle installed.

When Use the High-torque Spindle (ZS-650T)

When a high-torque spindle (ZS-650T) is installed, the range that you can actually cut (in the height direction) is subject to the following restrictions and is smaller than the maximum cutting range described earlier.

- Length of the installed tool
- Position of the XY table where the workpiece to cut is loaded
- If using a spacer for the T-slot table (ZA-600/500 series), the height of the spacer

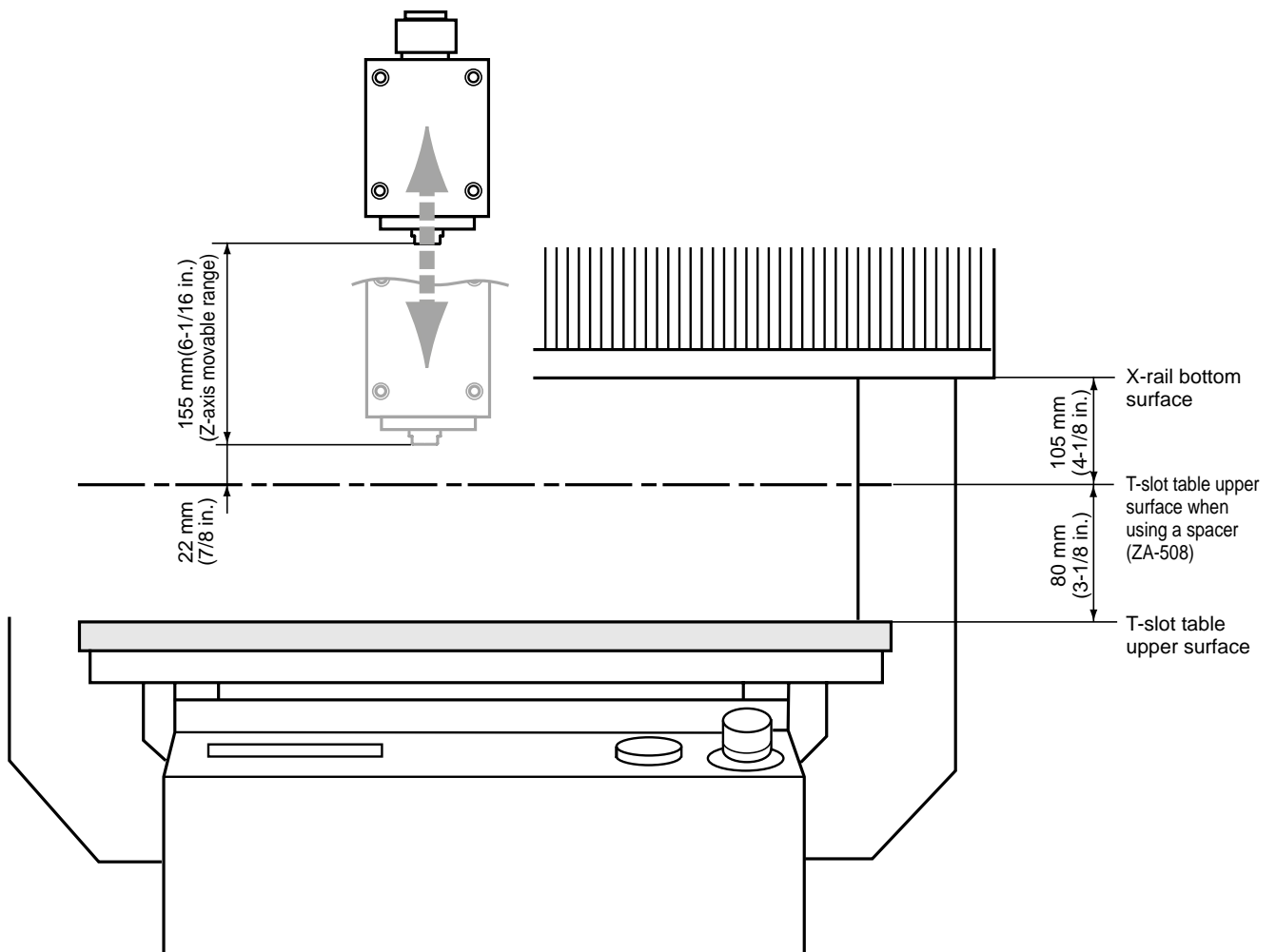

When Use the High-speed Spindle

When a high-speed spindle is installed, the range that you can actually cut (in the height direction) is subject to the following restrictions and is smaller than the maximum cutting range.

- Length of the installed tool
- Position of the XY table where the workpiece to cut is loaded
- If using a spacer for the T-slot table (ZA-600/500 series), the height of the spacer
- If using a depth regulator nose, the stroke of the spindle due to the nut (approx. 5 mm)

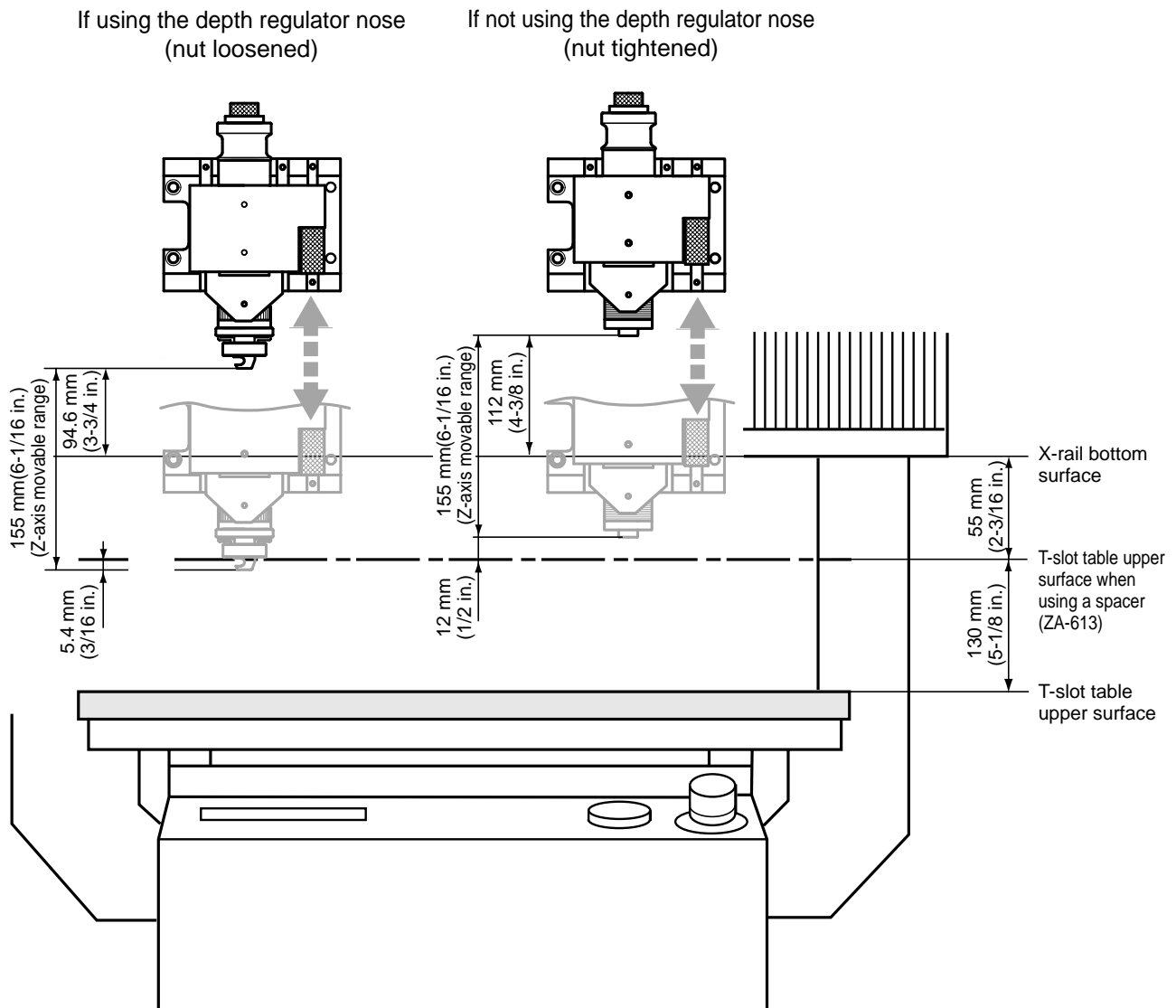

MDX-500

The maximum cutting area of the MDX-500 is 500 mm x 330 mm x 105 mm (19-5/8 in. x 12-15/16 in. x 4-1/8 in.). If you selected RML-1 as the command set, then when converted to coordinate values (step size: 1/100 mm), (x, y, z) = (50,000, 33,000, 10,500).

The actual cutting area of the MDX-500 differs according to the type of spindle installed.

When Use the High-torque Spindle (ZS-500T)

When a high-torque spindle (ZS-500T) is installed, the range that you can actually cut (in the height direction) is subject to the following restrictions and is smaller than the maximum cutting range described earlier.

- Length of the installed tool
- Position of the XY table where the workpiece to cut is loaded
- If using a spacer for the T-slot table (ZA-600/500 series), the height of the spacer

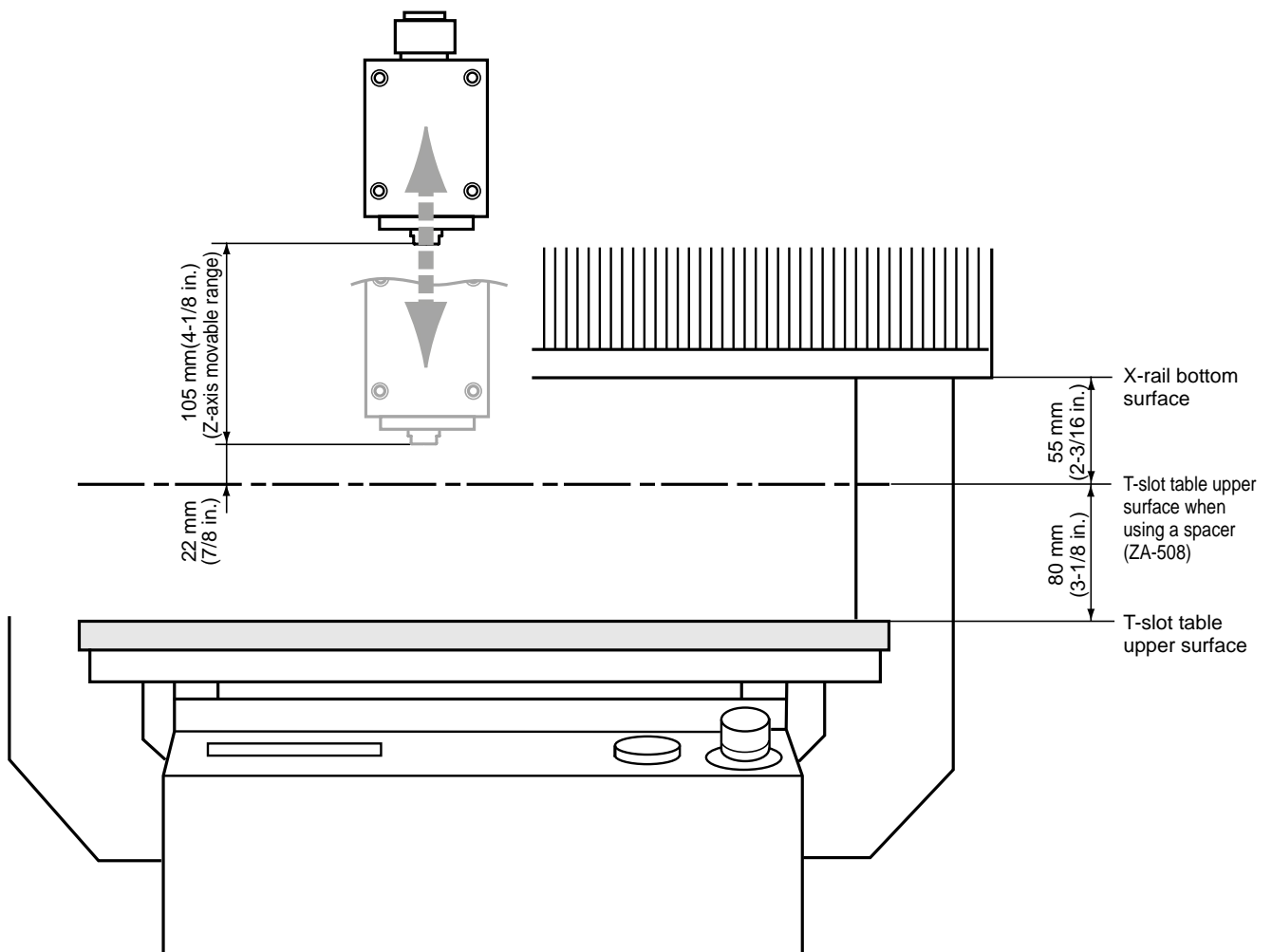

When Use the High-speed Spindle

When a high-speed spindle is installed, the range that you can actually cut (in the height direction) is subject to the following restrictions and is smaller than the maximum cutting range.

- Length of the installed tool
- Position of the XY table where the workpiece to cut is loaded
- If using a spacer for the T-slot table (ZA-600/500 series), the height of the spacer
- If using a depth regulator nose, the stroke of the spindle due to the nut (approx. 5 mm)

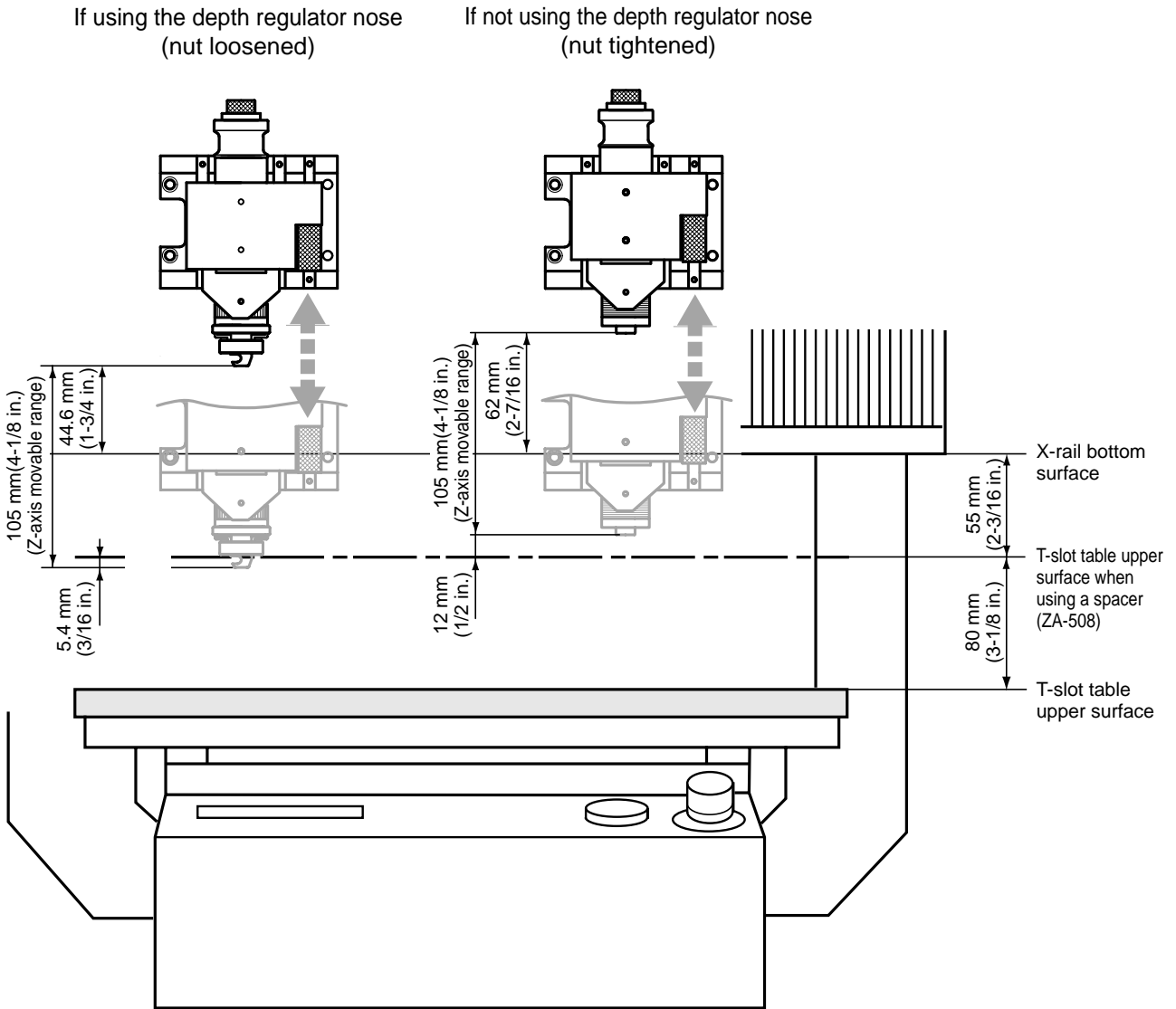

1-8 Loading a Workpiece for Cutting

CAUTION



Fasten the spindle, tool, and material securely in place.

Otherwise they may come loose during cutting, resulting in injury.

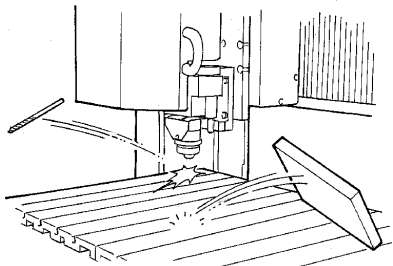

NOTICE When mounting a vise or loading a workpiece while a tool is installed, take care to avoid being injured by the tool.

This section describes how to load a workpiece when using the T-slot clamp included with the unit.



A spacer for the T-slot table (ZA-600/500 series) is optionally available and should be purchased if needed. For more information on how to install it on the unit, see "Part 3 Appendix."

- 1** Place the workpiece on the T-slot table.

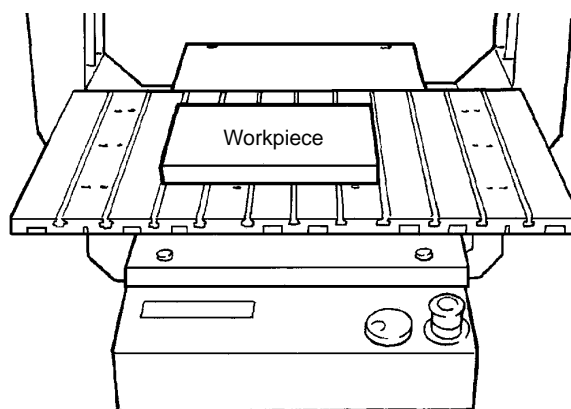

- 2** Pass the table-side end of the clamp for the T-slot clamp through the groove in the table as shown in the figure.

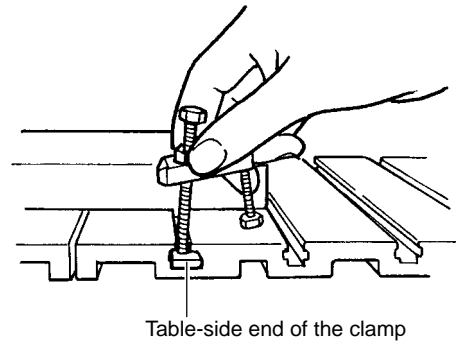

- 3** Turn the large bolts as shown in the figure to align the workpiece-side end of the clamp with the height of the secured portion.

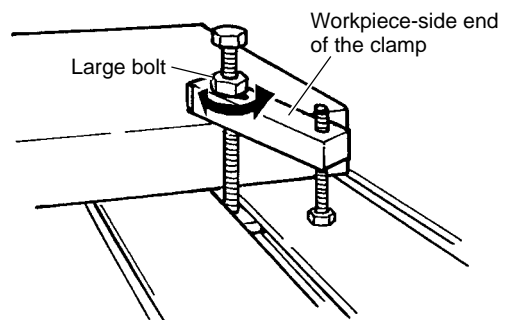

- 4** Turn the small bolts for the T-slot clamp until the angle of the workpiece-side end of the clamp is parallel with the secured portion, or slightly higher.

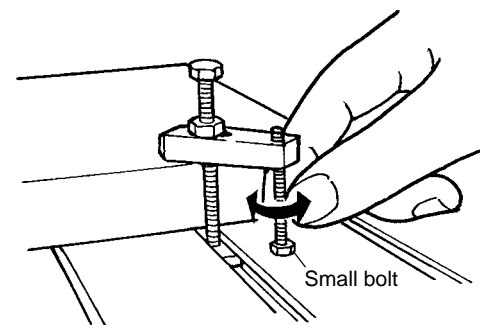

- 5** Use the wrench included with the unit to tighten.

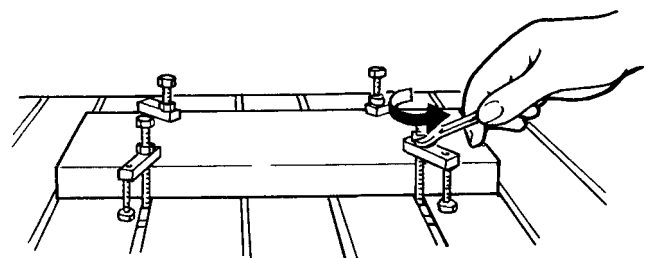

Part 2 Maintenance

2-1 Cleaning

⚠ CAUTION

! Switch off the machine and unplug the power cord from the electrical outlet before performing cleaning or maintenance.

Failure to do so may result in injury or electrical shock.

! Please use a vacuum cleaner to remove cutting dust. Do not use any blower like airbrush.

Otherwise, dust spread in the air may harm your health or damage this machine.

! When you're finished, wash your hands to rinse away all cuttings.



! Use a commercially available brush to remove metal cuttings.

Attempting to use a vacuum cleaner to take up metal cuttings may cause fire in the vacuum cleaner.



Cleaning the Main Unit

When the main unit becomes dirty, use a dry cloth to wipe it.

Cleaning After Operation

After cutting work is completed, use a vacuum cleaner to clean the MDX-650/500 main unit and the surrounding area of cutting dust. Be especially careful to remove the cutting waste from around the pleated part of the bellows cover and the connectors and terminals on the side of the machine.

If necessary, move the T-slot table to the front and rear, and clean the entire cover. In this case, switch on the power only when moving the T-slot table then switch it off and continue cleaning.

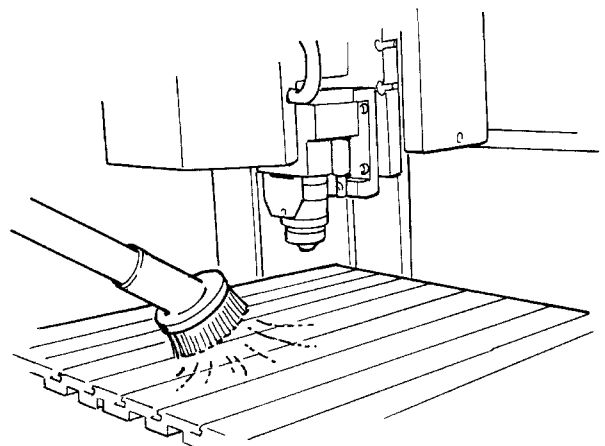

Cleaning with the Base Cover Open

If you're using the safety cover (ZBX-650/500A), you must detach the front part of the safety cover in advance. For information on how to detach the cover, refer to the "ZBX-650/500A Safety Cover User's Manual."

- 1** Switch on the power, move the table as far as it will go to the rear, then switch off the power and unplug the power cord from the electrical outlet.

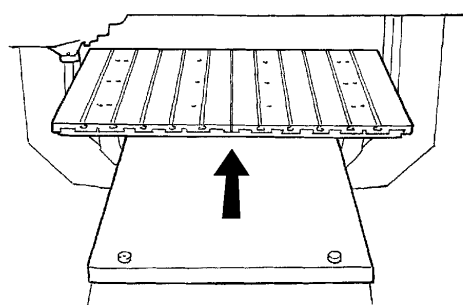

- 2** Remove the screws at the four places at the front and rear of the base cover.

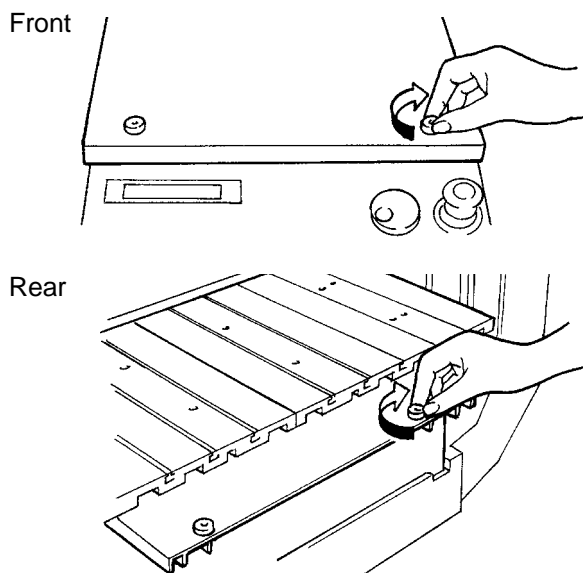

- 3** While lifting up the front part of the base cover, pull it back toward you to remove it.

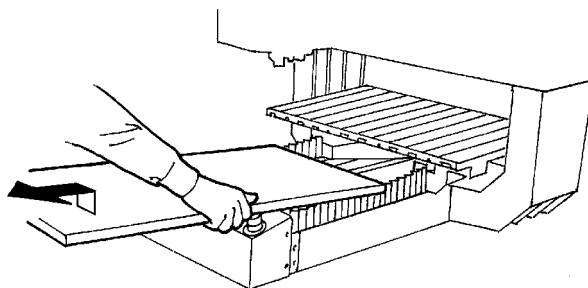

- 4** Use a vacuum cleaner to clean away any adhering cutting waste near the Y axis.

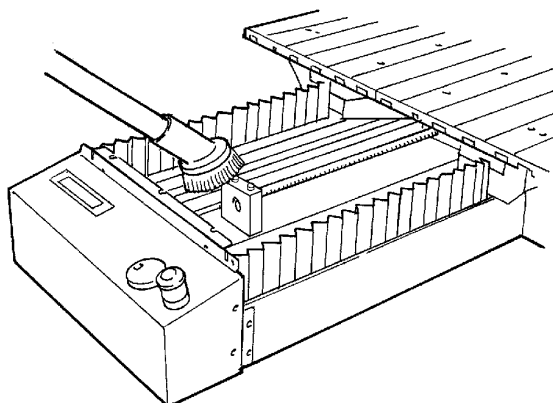

Cleaning Inside the Bellows Cover

As shown in the figure, pull out the bellows cover and use a vacuum cleaner to clean away any adhering cutting waste near the X axis or Z axis.

* When moving the head, switch on the power and use the control keys to move. After moving the head, be sure to switch off the power and unplug the power cord from the electrical outlet, and carry out cleaning.

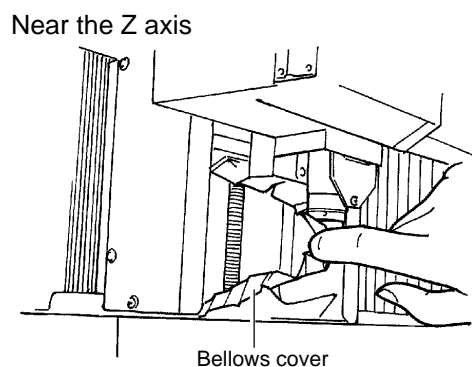
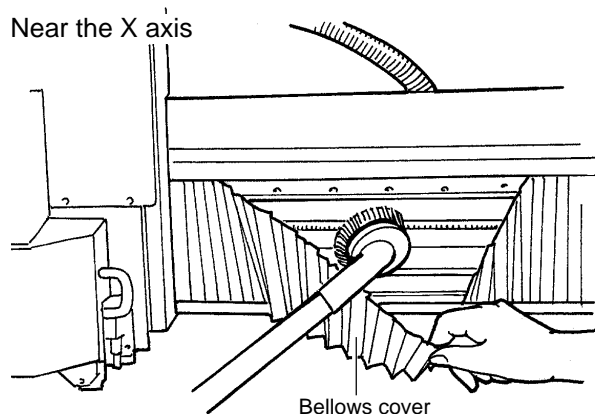

Cleaning the Sponge in the Fan-motor Area (MDX-500 Only)

Remove the filter cover, then clean away any built-up grime on the sponge inside.

* Install the filter cover with the convex surface facing upward. If installed upside-down, it may become impossible to detach.

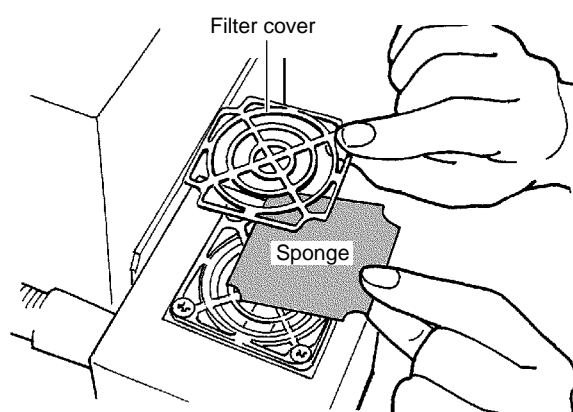

2-2 Checking the Spindle



A general guide to the service life of the spindle portion is shown below. We recommend prompt inspection and replacement.

-Spindle motor:	8000 hours	
-Spindle:	High-torque spindle.....5000 hours	High speed spindle.....1500 hours
-Spindle belt:	1500 hours	

Checking the Spindle Motor

Operate the spindle motor alone, with no tool installed or material loaded. If the rotation speed is uneven or marked noise is produced, be sure to contact a service technician.

Display of Spindle Rotation Time

The MDX-650/500 has a function for the displaying the total rotation time of the spindle.

1 Press the [EXIT] key several times to display the main menu.

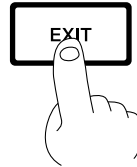

2 Turn the dial to move the arrow to [OTHERS], then press the [ENTER] key.

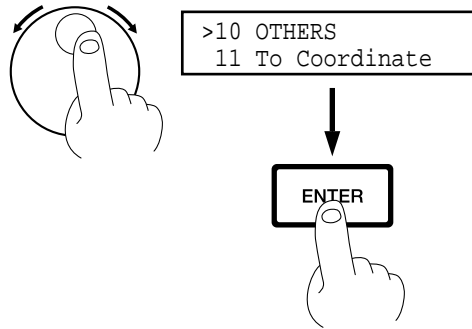

3 Turn the dial to move the arrow to [REVOLUTION TIME], then press the [ENTER] key.

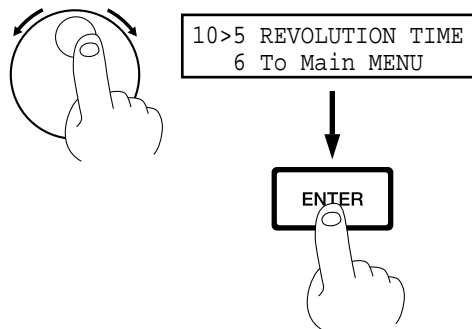

4 Check the total rotation time of the spindle.

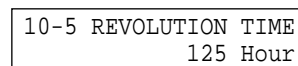

Adjusting the Tension of the Spindle Belt

This adjustment is required only for the belt for the high-torque spindle (ZS-650T/ZS-500T). We recommend checking it after approximately every 1,000 hours of working time.

First check the tension of the spindle belt. If this shows that the tension is outside the reference value, then adjust the tension.

Two special tools, a tension gauge (ST-001) and a tension adjuster (ST-040), are required to check the tension. These tools are sold separately as service parts. Contact your authorized Roland DG Corp. dealer or service center.

- 1** Remove the screws shown in the figure and detach the spindle motor cover.
(This requires a commercially available flathead screwdriver.)

MDX-650

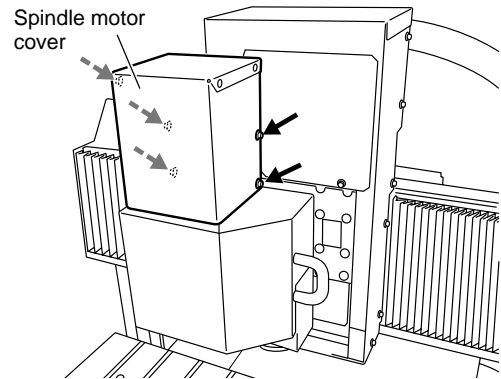

MDX-500

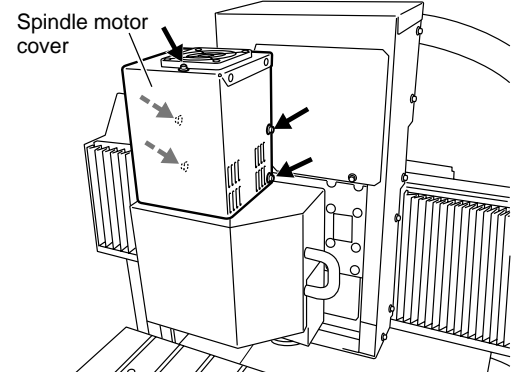

- 2** Loosen each of the four screws securing the spindle motor one half-turn.
(This requires a commercially available hexagonal wrench [size: 4 mm]. Use a tool with a ball-bit shape or ordinary shape and measuring at least 100 mm in length.)

Loosen these screws.

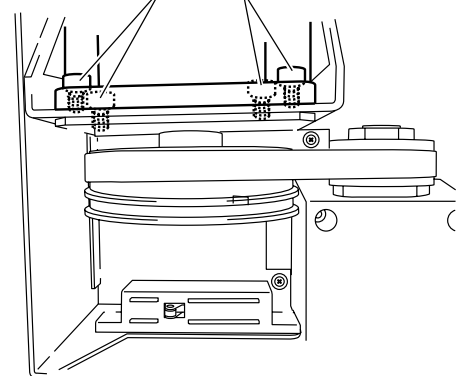

Continued on the next page

- 3** Set the tension adjuster (ST-040) in place at the location shown in the figure.

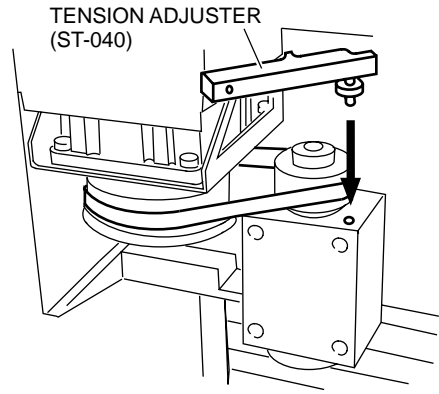

- 4** Press with the tension gauge (ST-001) until the tension adjuster (ST-040) touches the motor pulley, and read the value on the tension gauge.

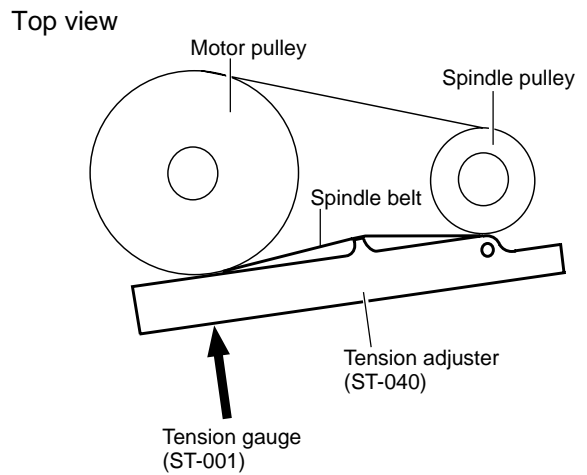

- 5** Use the nut shown in the figure to reposition the spindle motor so that the tension value is between 200 and 600 gf (2.45 and 5.88 N). (This requires a commercially available wrench or hexagonal wrench [size: 5.5 mm].)

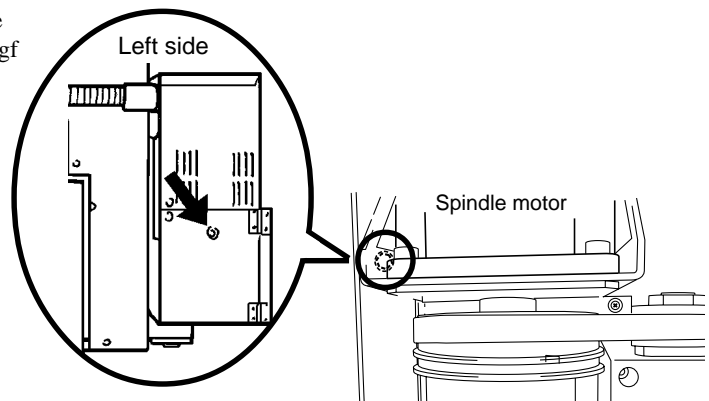

- 6** Secure the spindle motor in place by tightening the screws you loosened in step 2.

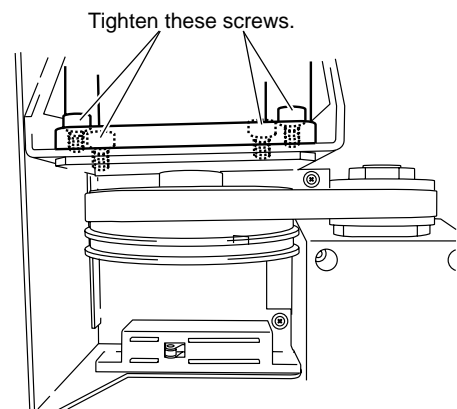

2-3 Lubricating the Ball Screw

CAUTION



Switch off the machine and unplug the power cord from the electrical outlet before performing cleaning or maintenance.

Failure to do so may result in injury or electrical shock.



Please use a vacuum cleaner to remove cutting dust. Do not use any blower like airbrush. Otherwise, dust spread in the air may harm your health or damage this machine.



When you're finished, wash your hands to rinse away all cuttings.



Use a commercially available brush to remove metal cuttings.

Attempting to use a vacuum cleaner to take up metal cuttings may cause fire in the vacuum cleaner.



To keep using your machine in normal working order, lubricate the ball screw after approximately every 1,000 hours of working time. Use Shell Alvania No. 0 grease.

X axis, Z axis

As shown in the figure, pull out the bellows cover and apply grease directly to the ball screw. Apply grease to the entire screw shaft, moving the head to expose ungreased areas. Finally, move the head a full stroke in the X-axis or Z-axis direction and wipe away excess grease.

* When moving the head, switch on the power and use the control keys to move. When you do this, return the pulled-out bellows cover to its original position. After you move the head, be sure to switch off the power and unplug the power cord from the electrical outlet before performing lubrication.

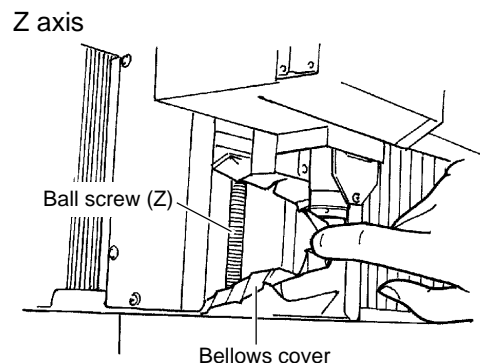
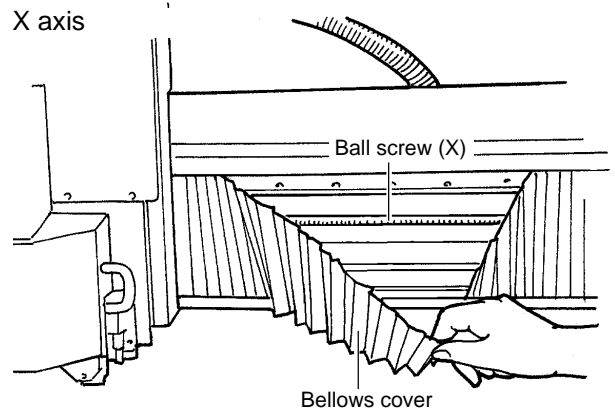

Y axis

- 1 Refer to "2-1 Cleaning__Cleaning with the Base Cover Open" and detach the base cover.

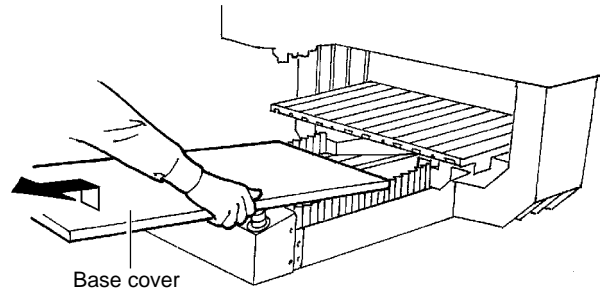

- 2 Apply grease directly to the ball screw. Apply grease to the entire screw shaft, moving the head to expose ungreased areas. Finally, move the head a full stroke in the Y-axis direction and wipe away excess grease.

* When moving the head, switch on the power and use the control keys to move. After you move the head, be sure to switch off the power and unplug the power cord from the electrical outlet before performing lubrication.

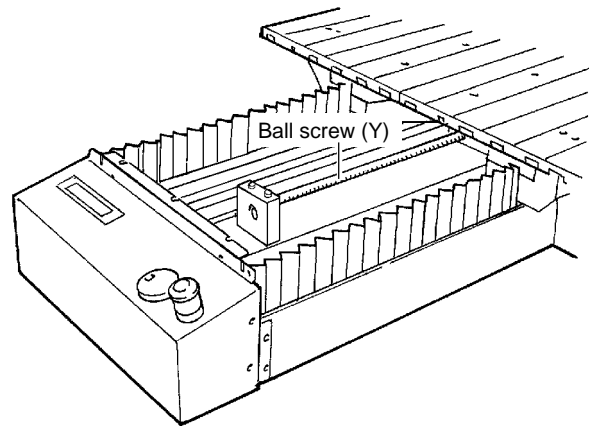

We recommend also cleaning away any buildup of cutting waste near the X, Y, and Z axes at the same time that you perform lubrication. (In "2-1 Cleaning," refer to "Cleaning with the Base Cover Open" and "Cleaning Inside the Bellows Cover.")

2-4 Recommended Service Checking

The MDX-650/500 is a precision machine. In order to maintain it safely for operation over the long term, we recommend that it should be checked by a qualified serviceman. There is a charge for this service. Please take note of this in advance.

Maintenance to Be Performed by a Service Technician

- Checking, cleaning, and lubricating the drive area (ball screw and linear guide)
- Checking consumable parts (spindle belt, spindle motor, spindle unit, and filter for the spindle-motor cooling fan)
- Verifying operation and functioning

Part 3 Appendix

3-1 The ZA-600/500 Series Spacer for the T-slot Table (Optional)

Checking the Accessories

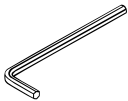

Hexagonal wrench

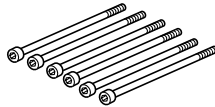

Screws: 6

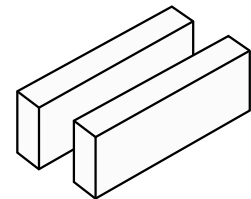

Spacers: 2

Installing on the MDX-650/500

- 1 Switch on the power, then press the [▼] key to move the table as far as it will go to the front.

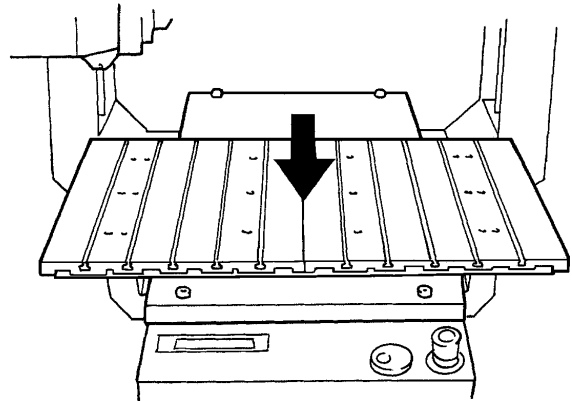

- 2 Turn the power OFF and unplug the power cord from the electrical outlet.

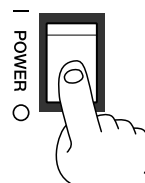

- 3** Use the hexagonal wrench included with the spacers to remove the screws at the six places shown in the figure, then detach the T-slot table.

* Do not throw away the screws. Screws are required when T-slot table is used without spacers.

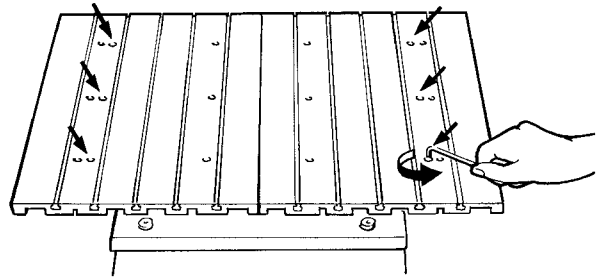

- 4** Align the pins on the spacers with the pin-holes on the slider, then place the spacers on the left and right.

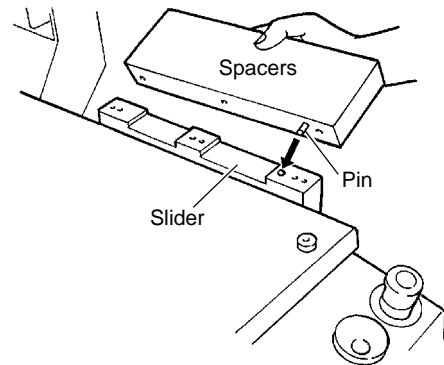

- 5** Align the T-slot table removed in step 3 with the pin-holes on the spacers and set into place.

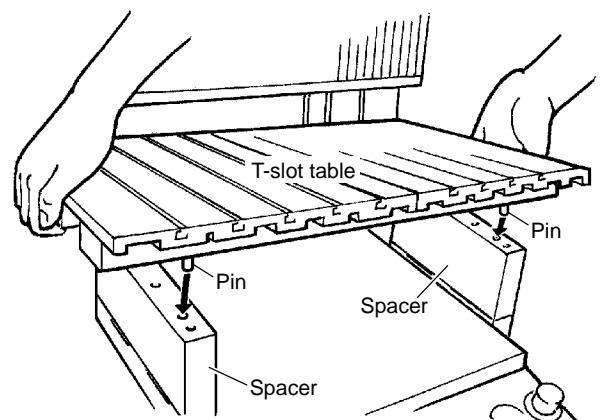

- 6** Secure in place at six locations with the screws included with the spacers.

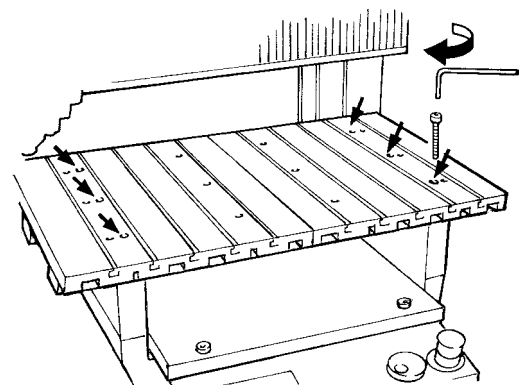

3-2 Other Optional Items

Spindle Area

	Collet	Cutting Tool	Vacuum adapter
High-torque Spindle *ZS-650T (For the MDX-650) *ZS-500T (For the MDX-500)	ø6 mm Standardly included with the spindle	ø6 mm End mill	*ZAD-500T
	ø10, ø8, ø6.35, ø5, ø4, ø3.2, ø3 mm *ZC-500T (Collet set)	ø10, ø8, ø6.35, ø5, ø4, ø3.2, ø3 mm End mill	
	ø6.35, ø4.36 mm *ZC-500TE (Collet and holder set) (ZS-500T only)	ø6.35, ø4.36 mm Engraving cutter	
High-speed Spindle *ZS-500SH	ø4.36 mm Standardly included with the spindle	ø4.36 mm Engraving cutter	*ZAD-500S
	ø6, ø5, ø4, ø3 mm *ZC-23 (Collet set)	ø6, ø5, ø4, ø3 mm End mill	
	ø6.35 mm *ZC-23-6.35	ø6.35 mm End mill	

Others

Spacer for the T-slot table	*ZA-503	3 cm (1-3/16 in.)
	*ZA-505	5 cm (1-15/16 in.)
	*ZA-508	8 cm (3-1/8 in.)
	*ZA-613	13 cm (5-1/8 in.)
Center Vise	*ZV-500C	
Vacuum Table	*ZV-500A	
Rotary Axis Unit	*ZCL-650	MDX-650 only
Safety Cover	*ZBX-650	for the MDX-650 (Weight: 68 kg (149.9 lb.))
	*ZBX-500	for the MDX-500 (Weight: 53 kg (116.8 lb.))

* Indicates option part number. For tool part numbers, see the supply-part catalog.

3-3 Specifications

MDX-650 Main Unit

	MDX-650
T-slot (XY) table size	700 mm x 480 mm (27-1/2 x 18-7/8 in.)
Max. cuttng area	650 mm(X) x 450 mm(Y) x 155 mm(Z) (25-9/16(X) x 17-11/16(Y) x 6-1/16(Z) in.)
XYZ motor	AC servo motor
Feed rate	X, Y, Z-axis: Max. 85 mm/sec. (3-3/8 in./sec.)
Acceleration	0.3G, 0.1G, 0.05G
Software resolution	[When RML-1 has been selected] 0.01 mm/step (0.00039 in.) [When NC codes has been selected] 0.001 mm/step (0.000039 in.) Note that the measurement unit for positioning coordinates is 0.01 mm/step (0.00039 in.).
Mechanical resolution	0.001 mm/step
Spindle motor	DC brushless motor Max. 400W (when with high-torque spindle)
Revolution speed	[High torque spindle] 3000 to 12000 rpm [High speed spindle] 5000 to 20000 rpm (Variable manually or by the command set)
Tool chuck	Collet or Cutter holder system
Positioning accuracy	±0.1 mm (0.00394 in.) / 300 mm (11-13/16 in.) (Under no-load conditions)
Repeat accuracy	±0.05 mm (0.00197 in.) (Under no-load conditions)
Origin-point reproducibility (when the power is switched on/off)	±0.08 mm (0.00315 in.)
Possible table load weight	[0.3G] 12 kg (26.5 lb.) or less [0.05G] 20 kg (44.1 lb.) or less
Interface	Parallel (in compliance with the specification of Centronics) Serial (under RS-232C standard)
Buffer size	2 Mbyte (Replot buffer: [RML-1] 2 Mbyte [NC codes] Max. 2 Mbyte (end-user setting))
Instruction system	RML-1 (mode1, mode2) or NC codes supported by the MDX-650 (Selectable through display operation)
Control keys	COPY, XY/A, Z, +Z(Tool up), -Z(Tool down), PAUSE, SPINDLE, ▲, ▼, ◀, ▶, FAST FEED, JOG EXIT, ENTER, Dial, EMERGENCY STOP switch
Power consumption	6.5 A / 117 V 3.5 A / 220 to 230 V 3.5 A / 230 to 240 V
Dimensions	930 mm(W) x 1085 mm(D) x 870 mm(H) (36-5/8(W) x 42-3/4(D) x 34-5/16(H) in.)
Weight	120 kg (264.5 lb.)
Packed dimensions	1060 mm(W) x 1260 mm(D) x 1090 mm(H) (41-3/4(W) x 49-5/8(D) x 42-15/16(H) in.)
Packed weight	160 Kg (352.7 lb.)
Operation temperature	5 to 40°C (41 to 104°F)
Operation humidity	35 to 80% (no condensation)
Accessories	T-slot clamps: 4, Bolts (5 x 25 mm): 4, Spanner: 1(10 mm(3/8 in.)), Z0position sensor: 1, Power cord: 1, Belt for high-torque spindle: 1, Key connector: 15, Roland Software Package CD-ROM: 1, Hexagonal wrench : 1, Ferrite core : 1, USER'S MANUAL: 3(1 Setup & Maintenance, 2 Cutting Using the Included Software, 3 Cutting Using NC codes), NC-code PROGRAMMER'S MANUAL: 1

MDX-500 Main Unit

	MDX-500
T-slot (XY) table size	550 mm x 360 mm (21-5/8 x 14-1/8 in.)
Max. cutting area	500 mm(X) x 330 mm(Y) x 105 mm(Z) (19-5/8(X) x 12-15/16(Y) x 4-1/8(Z) in.)
XYZ motor	AC servo motor
Feed rate	X, Y, Z-axis: Max. 85 mm/sec. (3-3/8 in./sec.)
Acceleration	0.3G, 0.1G, 0.05G
Software resolution	[When RML-1 has been selected] 0.01 mm/step (0.00039 in.) [When NC codes has been selected] 0.001 mm/step (0.000039 in.) Note that the measurement unit for positioning coordinates is 0.01 mm/step (0.00039 in.).
Mechanical resolution	0.001 mm/step
Spindle motor	DC brushless motor Max. 400W (when with high-torque spindle)
Revolution speed	[High torque spindle] 3000 to 12000 rpm [High speed spindle] 5000 to 20000 rpm (Variable manually or by the command set)
Tool chuck	Collet or Cutter holder system
Positioning accuracy	±0.1 mm (0.00394 in.) / 300 mm (11-13/16 in.) (Under no-load conditions)
Repeat accuracy	±0.05 mm (0.00197 in.) (Under no-load conditions)
Origin-point reproducibility (when the power is switched on/off)	±0.08 mm (0.00315 in.)
Possible table load weight	[0.3G] 12 kg (26.5 lb.) or less [0.05G] 15 kg (33.1 lb.) or less
Interface	Parallel (in compliance with the specification of Centronics) Serial (under RS-232C standard)
Buffer size	2 Mbyte (Replot buffer: [RML-1] 2 Mbyte [NC codes] Max. 2 Mbyte (end-user setting))
Instruction system	RML-1 (mode1, mode2) or NC codes supported by the MDX-500 (Selectable through display operation)
Control keys	COPY, XY, Z, +Z(Tool up), -Z(Tool down), PAUSE, SPINDLE, ▲, ▼, ◀, ▶, FAST FEED, JOG EXIT, ENTER, Dial, EMERGENCY STOP switch
Power consumption	6.5 A / 117 V 3.5 A / 220 to 230 V 3.5 A / 230 to 240 V
Dimensions	742 mm(W) x 843 mm(D) x 713 mm(H) (29-1/4(W) x 33-1/4(D) x 28-1/8(H) in.)
Weight	92 kg (202.8 lb.)
Packed dimensions	900 mm(W) x 970 mm(D) x 930 mm(H) (35-7/16(W) x 38-1/4(D) x 36-5/8(H) in.)
Packed weight	117 Kg (257.9 lb.)
Operation temperature	5 to 40°C (41 to 104°F)
Operation humidity	35 to 80% (no condensation)
Accessories	T-slot clamps: 4, Bolts (5 x 25 mm): 4, Spanner: 1(10 mm(3/8 in.)), Z0position sensor: 1, Belt for high-torque spindle: 1, Key connector: 1, Hexagonal wrench : 1, USER'S MANUAL: 3(1 Setup & Maintenance, 2 Cutting Using the Included Software, 3 Cutting Using NC codes), NC-code PROGRAMMER'S MANUAL: 1, Roland Software Package CD-ROM: 1, Power cord: 1

Interface specifications

Parallel

Standard	In compliance with the specification of Centronics
Input signal	$\overline{\text{STROBE}}$ (1 BIT), $\overline{\text{DATE}}$ (8 BITE)
Output signal	BUSY (1 BITE), $\overline{\text{ACK}}$ (1 BIT)
Level of input/output signals	TTL level
Transmission method	Asynchronous

Serial

Standard	RS-232C specification
Transmission method	Asynchronous, duplex data transmission
Transmission speed	4800, 9600, 19200, 38400 (Selected using panel keys.)
Parity check	Odd, Even, None (Selected using panel keys.)
Data bits	7 or 8 bits (Selected using panel keys.)
Stop bits	1 or 2 bits (Selected using panel keys.)

Parallel connector (in compliance with specifications of Centronics)

Signal number	Terminal number	Signal number	Pin Connection
NC	36	18	HIGH**
HIGH*	35	17	GND
NC	34	16	GND
GND	33	15	NC
HIGH*	32	14	NC
NC	31	13	HIGH*
GND	30	12	GND
	29	11	BUSY
	28	10	$\overline{\text{ACK}}$
	27	9	D7
	26	8	D6
	25	7	D5
	24	6	D4
	23	5	D3
	22	4	D2
	21	3	D1
	20	2	D0
	19	1	$\overline{\text{STROBE}}$

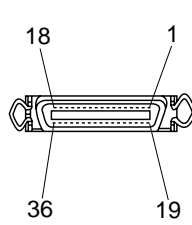

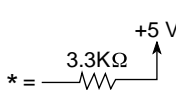
* = 

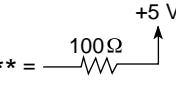
** = 

Serial connector (RS-232C)

Signal number	Terminal number	Signal number	Pin Connection
NC	25	13	NC
	24	12	NC
	23	11	NC
	22	10	NC
	21	9	NC
DTR	20	8	NC
NC	19	7	SG
	18	6	DSR
	17	5	CTS
	16	4	RTS
	15	3	RXD
	14	2	TXD
		1	

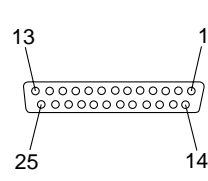

About the Expansion connector

EXT.2

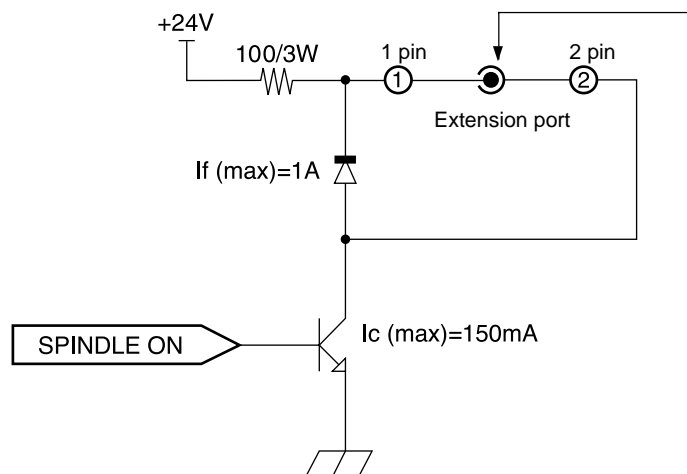

This circuit is activated when the spindle motor is in operation.

NOTICE Use within the rated range shown above.

Do not apply voltage greater than 25 V to the terminal.

Do not short the terminal to ground.

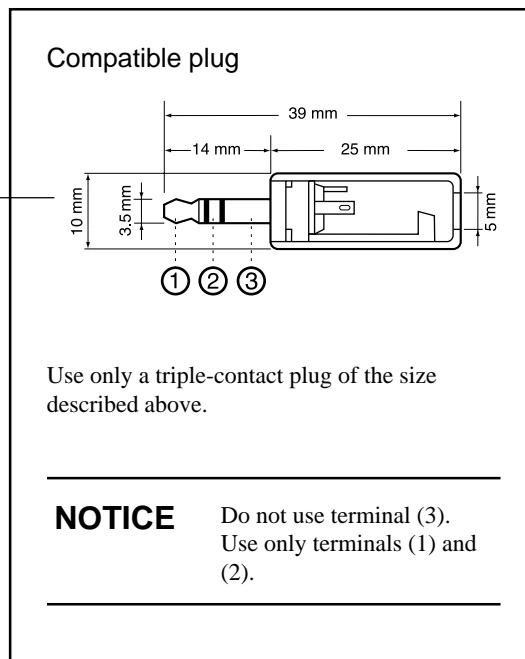

No responsibility is assumed for effects to which any equipment connected to this external output connector is subjected.

EXT.1 and EXT.3

The EXT.1 and EXT.3 (expansion connector) is provided for expansion use by Roland DG Corp. Its specifications are proprietary. Roland DG Corp. assumes no responsibility for any effect on equipment due to the use of this port by the user.

MDX-650 Dimensional Drawing

*Unit: mm

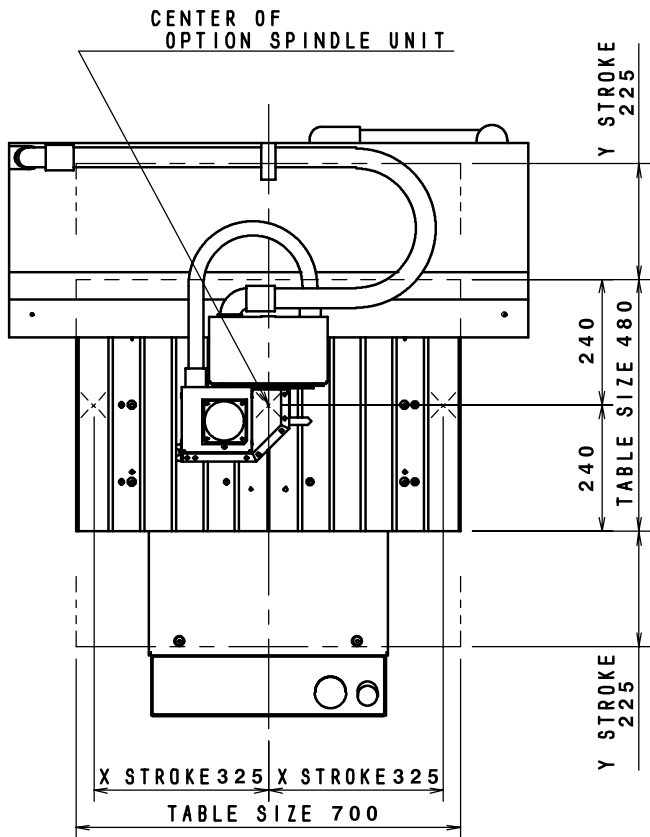

DETAIL: Y SLIDER

- A: HOLE (φ6) (FOR T-SLOT TABLE)
- B: ELLIPSE HOLE (6×8) (FOR T-SLOT TABLE)
- C: M6 SCREW (FOR T-SLOT TABLE)

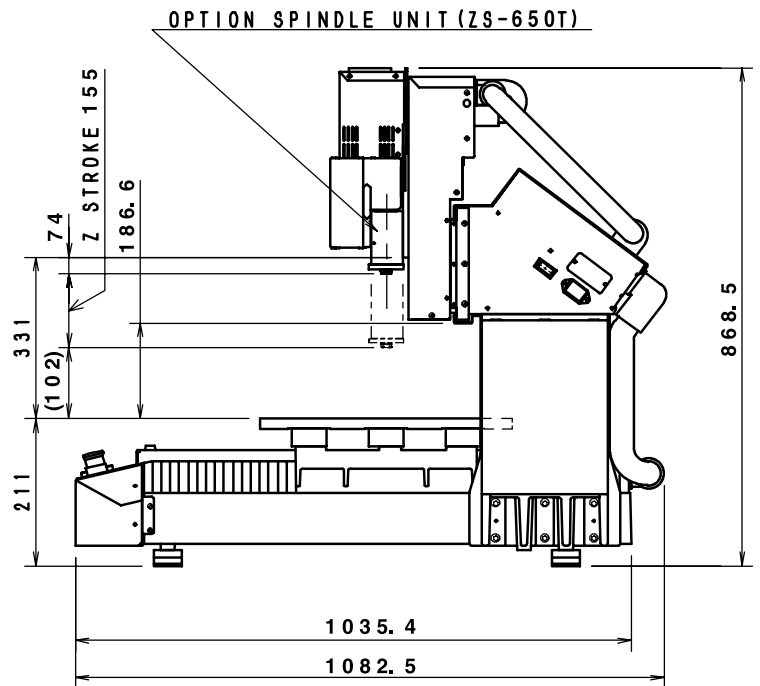
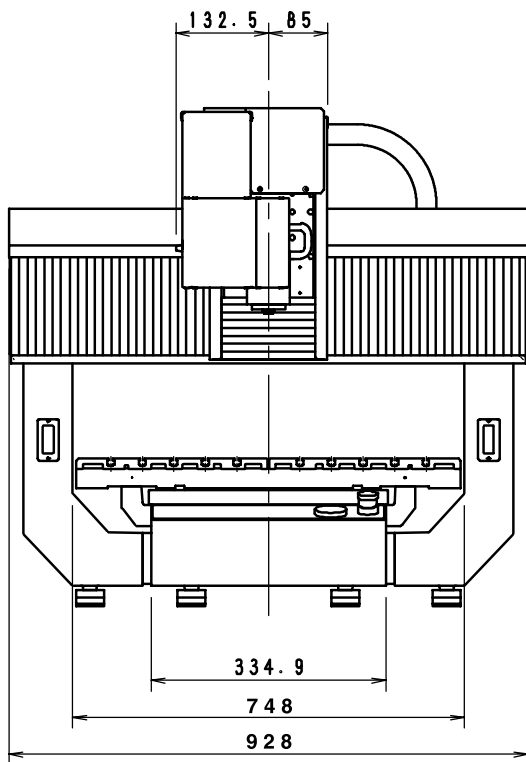
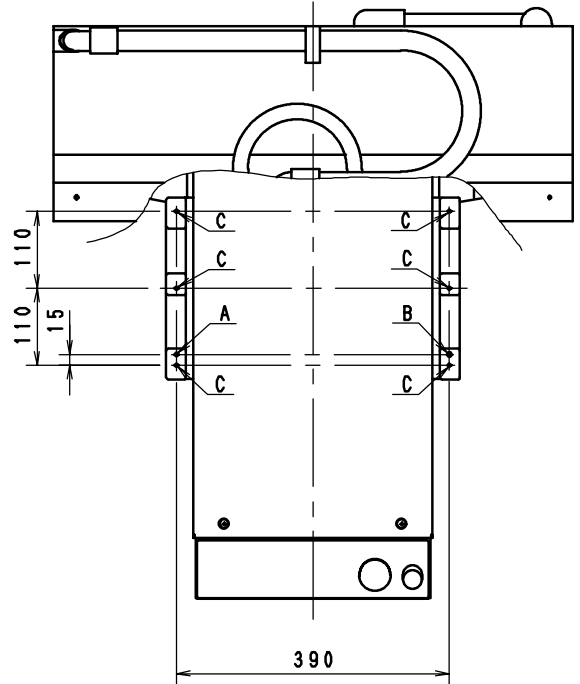

DETAIL:T-SLOT TABLE

A:HOLE (FOR M6 HEXAGON SOCKET HEAD CAP SCREWS)
 B:HOLE (φ5)
 C:ELLIPSE HOLE (5*7)

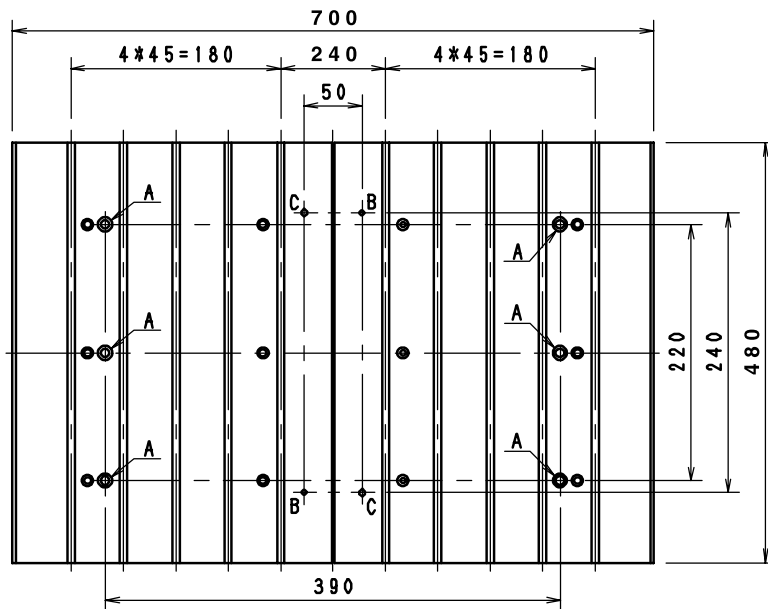

DETAIL:T-SLOT

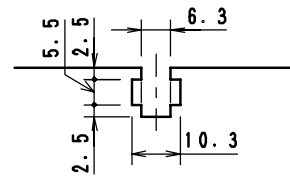

DETAIL:HEAD UNIT

CENTER OF OPTION SPINDLE UNIT

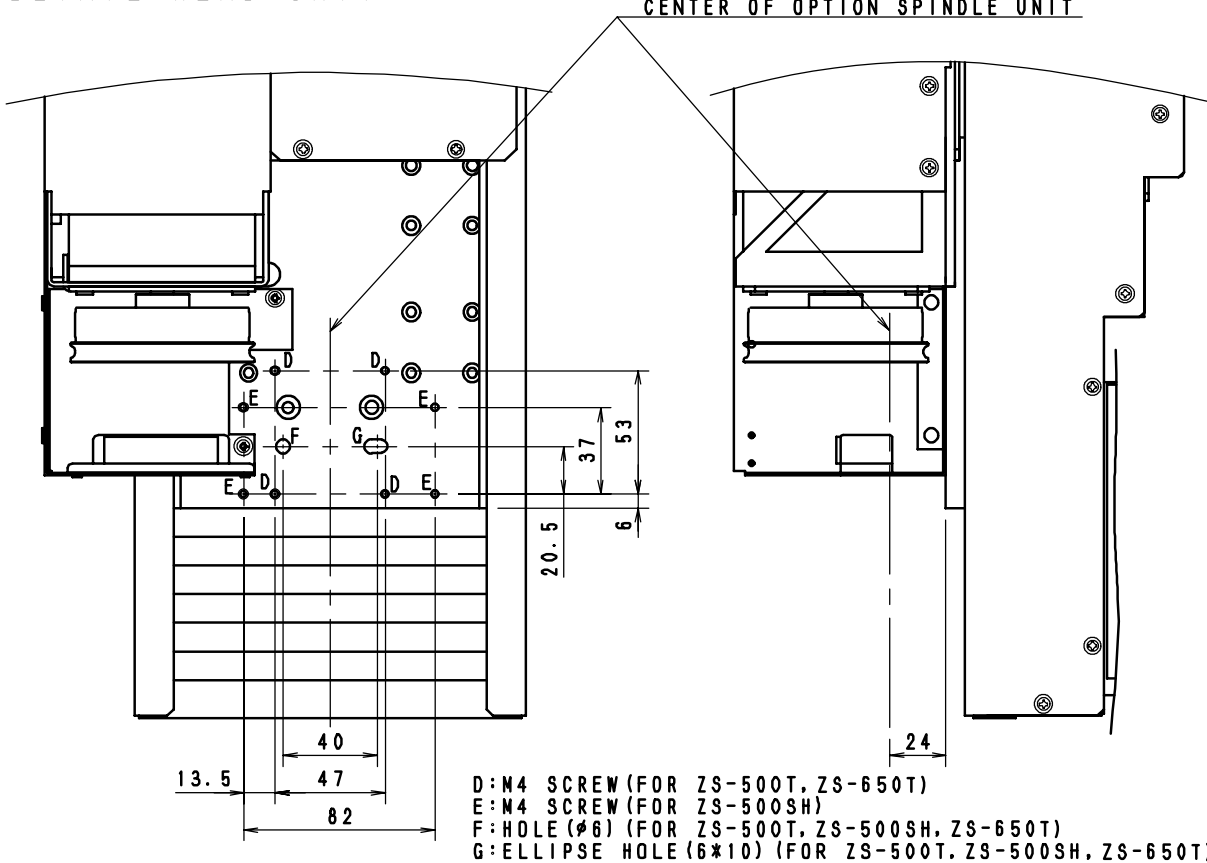

MDX-500 Dimensional Drawing

*Unit: mm

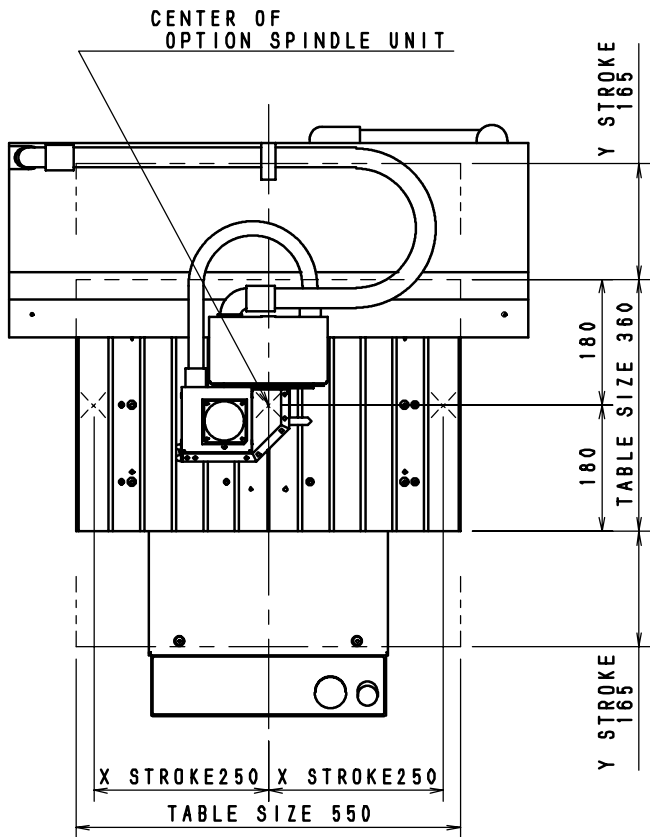

DETAIL: Y SLIDER

- A: HOLE (φ6) (FOR T-SLOT TABLE)
- B: ELLIPSE HOLE (6*8) (FOR T-SLOT TABLE)
- C: M6 SCREW (FOR T-SLOT TABLE)

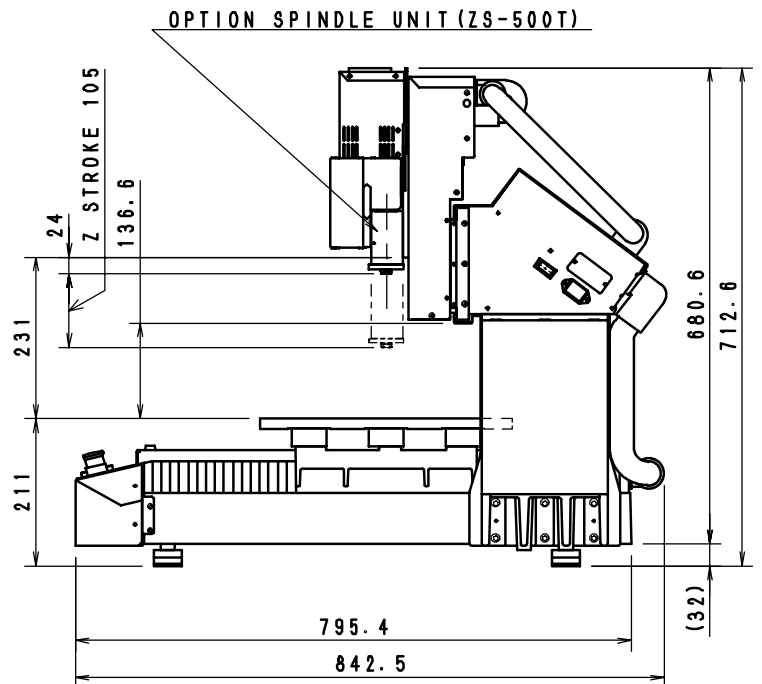
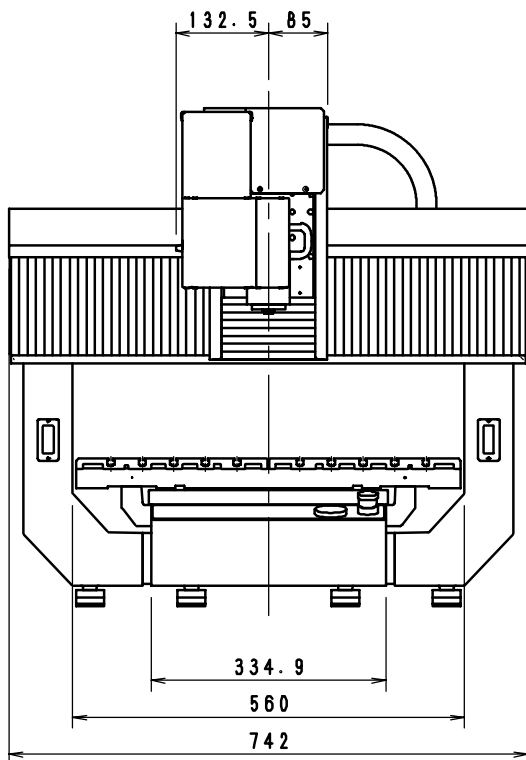
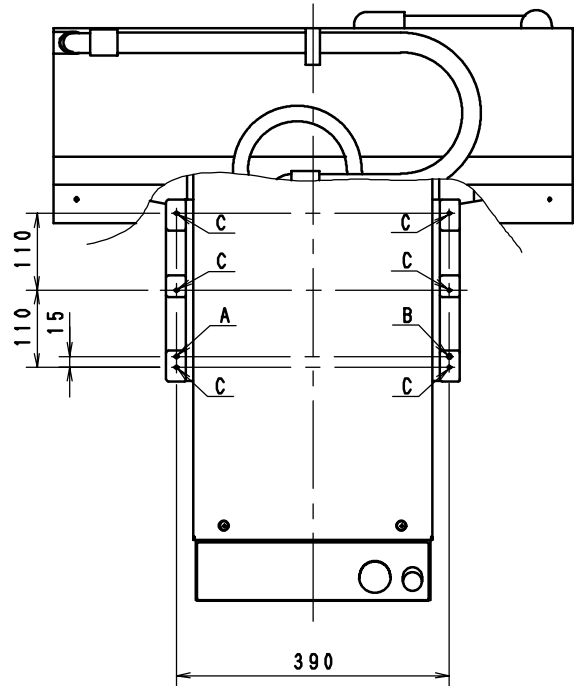

DETAIL:T-SLOT TABLE

A:HOLE (FOR M6 HEXAGON SOCKET HEAD CAP SCREWS)
 B:HOLE (φ5)
 C: ELLIPSE HOLE (5*7)

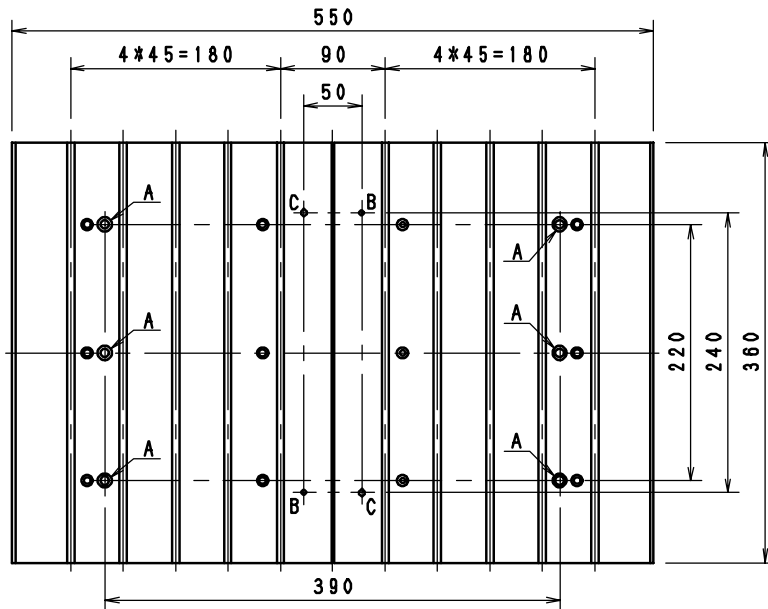

DETAIL:T-SLOT

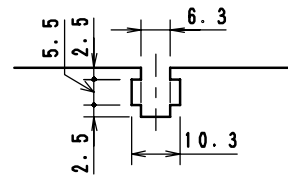

DETAIL:HEAD UNIT

CENTER OF OPTION SPINDLE UNIT

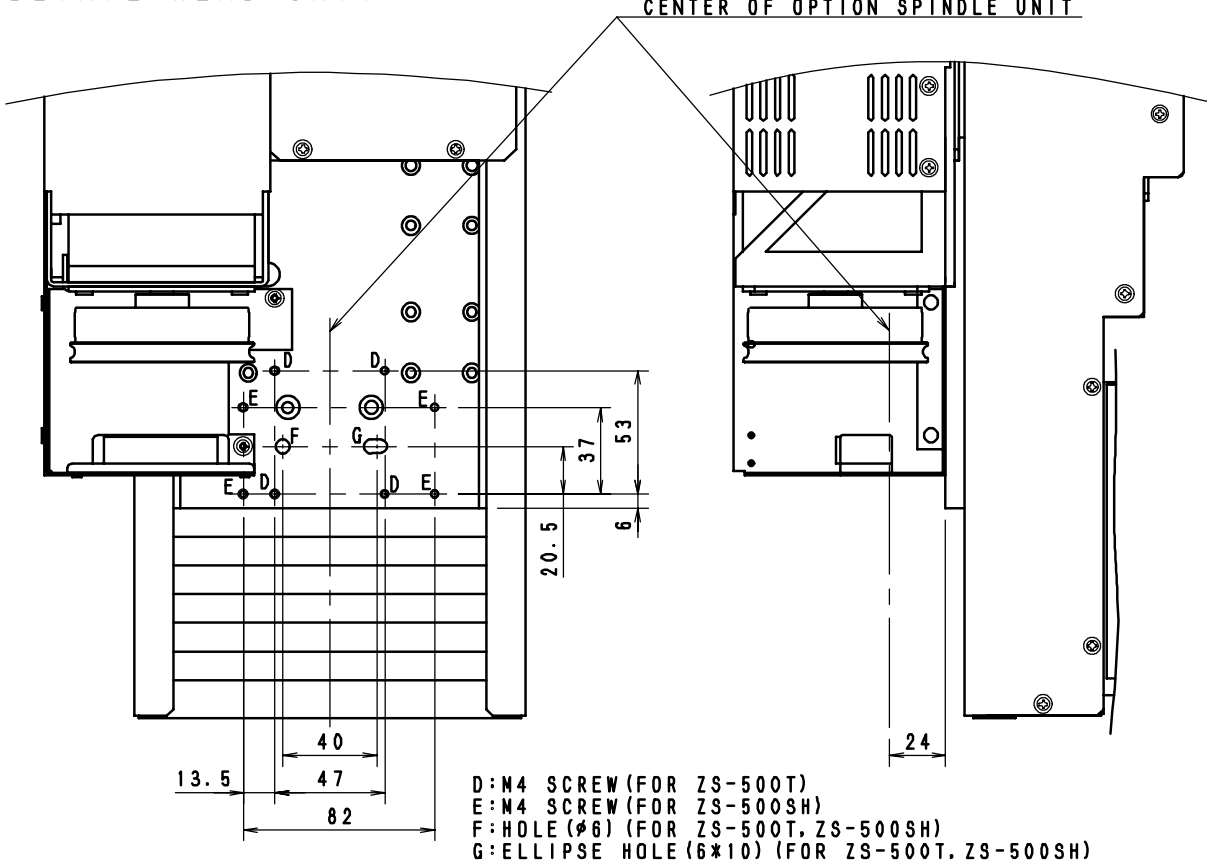

D:M4 SCREW (FOR ZS-500T)
 E:M4 SCREW (FOR ZS-500SH)
 F:HOLE (φ6) (FOR ZS-500T, ZS-500SH)
 G: ELLIPSE HOLE (6*10) (FOR ZS-500T, ZS-500SH)

Please read this agreement carefully before opening the sealed package or the sealed disk package

Opening the sealed package or sealed disk package implies your acceptance of the terms and conditions of this agreement.

Roland License Agreement

Roland DG Corporation ("Roland") grants you a non-assignable and non-exclusive right to use the COMPUTER PROGRAMS in this package ("Software") under this agreement with the following terms and conditions.

- | | |
|-----------------------------|---|
| 1. Coming into Force | This agreement comes into force when you purchase and open the sealed package or sealed disk package.
The effective date of this agreement is the date when you open the sealed package or sealed disk package. |
| 2. Property | Copyright and property of this Software, logo, name, manual and all literature for this Software belong to Roland and its licensor.

The followings are prohibited :
(1) Unauthorized copying the Software or any of its support file, program module or literature.
(2) Reverse engineering, disassembling, decompiling or any other attempt to discover the source code of the Software. |
| 3. Bounds of License | Roland does not grant you to sub-license, rent, assign or transfer the right granted under this agreement nor the Software itself (including the accompanying items) to any third party.
You may not provide use of the Software through time-sharing service and/or network system to any third party who is not individually licensed to use this Software.

You may use the Software by one person with using a single computer in which the Software is installed. |
| 4. Reproduction | You may make one copy of the Software only for back-up purpose. The property of the copied Software belongs to Roland.
You may install the Software into the hard disk of a single computer. |
| 5. Cancellation | Roland retains the right to terminate this agreement without notice immediately when any of followings occurs :
(1) When you violate any article of this agreement.
(2) When you make any serious breach of faith regarding this agreement. |
| 6. Limitations on Liability | Roland may change the specifications of this Software or its material without notice.

Roland shall not be liable for any damage that may caused by the use of the Software or by exercise of the right licensed by this agreement. |
| 7. Governing Law | This agreement is governed by the laws of Japan, and the parties shall submit to the exclusive jurisdiction of the Japanese Court. |