

# OPERATION MANUAL

## 8011 Trotec Speedy 300 C12 / C25 / C30 / C45 / C60 / C75/ C85/ C95/ C105/ C120

### Part A - Hardware



1st Issue 04/2005

© This documentation with all illustrations is intellectual property of  
**Trotec Produktions- u. Vertriebs GmbH.**

The entire documentation is given to the user for personal use only.  
This documentation must not be reproduced or made available to others without our written  
permission. Any breach of law will be prosecuted.

**Trotec GmbH**

Linzer Strasse 56  
A – 4600 Wels

Ph.: ++43/7242/239-0  
Fax: ++43/7242/239/7380  
E-Mail: [trotec@trotec.net](mailto:trotec@trotec.net)

## Operation Manual Trotec Speedy 300



### TROTEC PRODUKTIONS UND VERTRIEBS GmbH

Linzer Strasse 156  
A – 4600 Wels  
AUSTRIA

Ph.: ++43/7242/239-0

Fax: ++43/7242/239-7380

E-Mail: [trotec@trotec.net](mailto:trotec@trotec.net)

[www.troteclaser.com](http://www.troteclaser.com)



TROTEC cannot be held responsible for any direct or indirect damages, which result from using or working with the products electric circuits or software described herein. The apparatus must be used only by trained and skilled personnel. Before use the manual should be read and followed carefully.

Furthermore TROTEC reserves the right to change or alter any product described herein without prior notice.



In case of failure, please check the device first according to section 6.1 (page 62) - Troubleshooting. If unsuccessful, please note all data of the device (year of manufacture, software version, etc.) and call us from a telephone next to the switched on device.

For queries or technical problems please contact your dealer or TROTEC directly at the above address.

**Trotec GmbH**

Linzer Strasse 56  
A – 4600 Wels

Ph.: ++43/7242/239-0  
Fax: ++43/7242/239/7380  
E-Mail: [trotec@trotec.net](mailto:trotec@trotec.net)

# Operation Manual Trotec Speedy 300

## TABLE OF CONTENTS

<b>SECTION 1 – GENERAL</b> .....	<b>5</b>
<b>1.1 Operation Manual Use. – General Information</b> .....	<b>6</b>
<b>1.2 Designated Use</b> .....	<b>7</b>
<b>1.3 Technical Data / Device Specification</b> .....	<b>8</b>
<b>1.4 Manufacturer's Label</b> .....	<b>10</b>
<b>1.5 EU – Declaration of conformity</b> .....	<b>11</b>
<b>SECTION 2 – SAFETY</b> .....	<b>13</b>
<b>2.1 General Safety Information</b> .....	<b>15</b>
<b>2.2 Laser Safety Information</b> .....	<b>17</b>
<b>2.3 Safety Precautions when Operating the Device</b> .....	<b>18</b>
<b>2.4 Warning and Information Labels</b> .....	<b>19</b>
<b>SECTION 3 – BEFORE OPERATION</b> .....	<b>22</b>
<b>3.1 Unpacking the Speedy</b> .....	<b>23</b>
<b>3.2 Contents of Delivery</b> .....	<b>24</b>
<b>3.3 Location</b> .....	<b>26</b>
<b>3.4 Exhaust System – Requirements</b> .....	<b>27</b>
<b>3.5 Cooling System – Requirements</b> .....	<b>27</b>
<b>3.6 Computer – Requirements</b> .....	<b>27</b>
<b>3.7 Connecting the Speedy 300</b> .....	<b>28</b>
<b>SECTION 4 – OPERATION</b> .....	<b>35</b>
<b>4.1 System View / Assemblies and Control Elements</b> .....	<b>36</b>
<b>4.2 Control Panel</b> .....	<b>40</b>
<b>4.3 First Steps Before Engraving</b> .....	<b>45</b>

# Operation Manual Trotec Speedy 300

4.4 First Engraving Tests .....	49
4.5 Rotary Engraving Attachment.....	51
4.6 Tips and Tricks for Laser Engraving .....	57
4.7 Tips and Tricks for Laser Cutting .....	59
4.8 Tips and Tricks for the Production of Rubber Dies.....	60
<b>SECTION 5 – MAINTENANCE.....</b>	<b>61</b>
5.1 Cleaning the System.....	62
5.2 Cleaning the Optical Parts .....	63
5.3 Maintenance Plan .....	68
<b>SECTION 6 – ADDITIONAL INFORMATION .....</b>	<b>69</b>
6.1 Tips for Troubleshooting.....	70
6.2 Requirements for the Serial Cable.....	71
6.3 Wiring diagrams – 10W...30W.....	72
6.3 Wiring diagrams - 40W .....	73
6.3 Wiring diagrams – 60W air cooled.....	74
6.3 Wiring diagrams – 60W water cooled 110V.....	75
6.3 Wiring diagrams – 60W water cooled 230V.....	76
6.3 Wiring diagrams – 100W.....	77
6.3 Wiring diagrams – IO board .....	78
6.4 Support Sheet .....	79
<b>APPENDIX .....</b>	<b>81</b>
<b>Options.....</b>	<b>82</b>

# Operation Manual Trotec Speedy 300

## SECTION 1 – GENERAL

- 1.1 General Information on the Use of the Operation Manual
- 1.2 Designated Use
- 1.3 Technical Data / Device Specification
- 1.4 Manufacturer's Label
- 1.5 EU Conformity Declaration
- 1.6 Warranty Regulations

# Operation Manual Trotec Speedy 300

## 1.1 Operation Manual Use. – General Information

### Caution:

Please read and follow this Operation Manual carefully, before installation and operation. Damage to persons and/or material can result from not following individual points of the Operation Manual!

Operation of the system is only permitted with equipment and spare parts supplied or listed in the spare parts and consumables lists.

Auxiliary equipment must be adjusted to the base machine (any queries to dealer or manufacturer).

The following symbols are used for easier understanding of the Operation Manual:



If the Operation Manual is not observed, this area represents a particular danger for the operating personnel or the personnel responsible for maintenance.



Caution: This component is under voltage. In these areas strictly observe the safety instructions regarding electricity, care is to be taken in particular during maintenance and repair work.



Caution: In this area pay attention to the possible dangers of the laser beam.



Note or information on individual components of the device, that simplify the use or make it more understandable.

**(30/11)**

Reference to several parts, which are described in more detail on a different page of the Operation Manual. The first number indicates the page, the second number indicates the part number on this page.

# Operation Manual Trotec Speedy 300

## 1.2 Designated Use

The TROTEC laser engraver, Speedy 300, is used for engraving and cutting of signs, stamps and suchlike.

A wide variety of materials such as rubber, acrylic, coated metal, tin, special steel, elox-aluminum, cork, cardboard, glass, leather, marble, several plastics and wood can be processed on the laser engraver.



The engraving process must only be performed with a perfectly adjusted machine (see also Section 4 – Operation).



Use of the system in other areas is against the designated use. The manufacturer does not admit liability for damage to personal and/or equipment resulting from such use.



The system must only be operated, maintained and repaired, by personnel that are familiar with the designated field of use and the dangers of the machine !



Non-observance of the instructions for operation, maintenance and repair described in this Operation Manual excludes any liability of the manufacturer if a defect occurs.

# Operation Manual Trotec Speedy 300

## 1.3 Technical Data / Device Specification

<b>Model designation</b>	8011 Speedy 300
<b>max. engraving surface</b>	730 x 436 mm
<b>max. workpiece size</b>	800 x 460 x 200 mm
<b>max. engraving speed</b>	355 cm/sec.
<b>Laser type</b>	12 W sealed-off CO <sub>2</sub> laser air-cooled
25 W sealed-off CO <sub>2</sub> laser air-cooled	30 W sealed-off CO <sub>2</sub> laser air-cooled
45 W sealed-off CO <sub>2</sub> laser air-cooled	60 W sealed-off CO <sub>2</sub> laser water-cooled
60 W Sealed-off CO <sub>2</sub> - Laser air-cooled	75 Watt Sealed-off CO <sub>2</sub> - Laser air-cooled
85 W Sealed-off CO <sub>2</sub> - Laser air-cooled	95 W Sealed-off CO <sub>2</sub> - Laser air-cooled.
105 W Sealed-off CO <sub>2</sub> - Laser water-cooled	120 W Sealed-off CO <sub>2</sub> - Laser water-cooled
<b>Wavelength of the laser radiation</b>	10.6 µm
<b>Focal length</b>	1.5 inch (standard lens), 2.5 + 2 inch as option
<b>Repetition accuracy of positioning</b>	+/- 0.025 mm
<b>Interfaces</b>	1 x serial = RS-232C PC
<b>Dimensions</b>	1090 x 890 x 590 mm
<b>Weight</b>	depending on laser
	depending on laser
<b>Safety class (without Laserpointer)</b>	Class 2 / USA Class II
<b>Height adjustment of working surface</b>	200 mm
<b>Average power consumption</b>	Speedy C12: 400 W Speedy C25+30: 700 W Speedy C45: 1000W Speedy C60: 1300 W Speedy C100: 3000 W
<b>Sound pressure level</b>	70 dB(A)

### Prerequisite for the installation:



Mains: AC voltage; 220 - 240 V; 50 Hz; 16A fuse rating  
AC voltage; 100 - 120 V; 60 Hz; 20A fuse rating

Room temperature 15 ° to 25 °C

# Operation Manual Trotec Speedy 300

Air humidity <70%

# Operation Manual Trotec Speedy 300

## 1.4 Manufacturer's Label

The manufacturer's label is located on the back of the device (see Figure below).

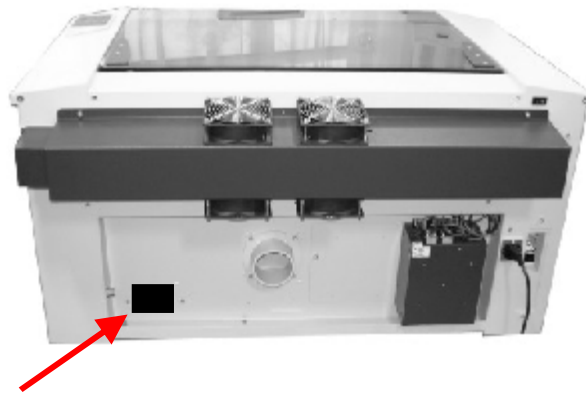

Figure 1

It is recommended to enter data such as serial number and year of manufacture into the manufacturer's label below so that you always have this data handy if you have problems with your device or require spare parts.

TROTEC LASER ENGRAVER		
Model:	Typ:	8007 Speedy C25
Seriennummer:	Serial No:	SP2010
Baujahr:	Manufactured:	Jan/2003
Stromaufnahme	Input Power:	220-240VAC~, 3,6A, 50Hz
Hersteller:	Manufacturer:	TROTEC Produktions u. Vertriebs Ges.m.b.H Linzerstraße 156, 4600 Wels AUSTRIA
CO <sub>2</sub> -Laser, max. power 75Wcw, wavelength 10,6µm Laserdiode max.power<0,99mWcw, wavelength 655nm EN 60825-1 (1994)		
CE		www.trotec.net

# Operation Manual Trotec Speedy 300

## 1.5 EU – Declaration of conformity

The manufacturer

**TROTEC Produktions- u. Vertriebs GmbH.**

Linzer Strasse 156,  
A-4600 Wels, OÖ.,  
AUSTRIA

hereby declares that the following product

**TROTEC 8011 SPEEDY 300**  
**Model N° 8007 Speedy C12/25/30/45/60/75/85/95/105/120**

has demonstrated conformity to the following guidelines:

89/336/EEC Directive for Machines (392 )  
73/23/EEC Low Voltage Directive  
89/336/EEC EMC Guideline and  
92/31/EEC Amendment

Applied during design and construction of this product:

- EN 60335-1 Safety of Household and Similar Appliances
  - EN 55014/1993 Electromagnetic Compatibility
    - EN 55014/1995
    - EN 60204-1 Machine Safety
  - EN 60825-1/1997 Safety of Laser Equipment
- EN 60950/A1+A2 Safety of Electric Devices for Informatics Including Electric Office Machines
- EN 55022/94 and EN 50082-2/95 Electromagnetic Compatibility

Wels, 8th April, 2005

Trotec Produktions u. Vertriebs Ges.m.b.H



# Operation Manual Trotec Speedy 300

## 1.6 Warranty Regulations

<b>LIMITED WARRANTY TERMS AND CONDITIONS FOR TROTEC SPEEDY 300 SERIES</b>
---

Trotec Produktions- und Vertriebs GmbH, Wels (hereinafter referred to as "Trotec") grants the purchaser at his discretion a claim within the terms of the following warranty obligations in addition to the statutory warranty claims against the seller.

### Beginning and duration of warranty

1. The warranty period shall begin with the date of invoice by Trotec. No extension of the original warranty period occurs by any substitute deliveries or repairs for warranty reasons.
2. Warranty is granted for the following period of time:

36 Months <sup>4</sup>	Housing, print (CPU, motor main, axis), power supply, control board, compressor for air assist, belts, all mechanic components, laser assembly <sup>1</sup>
3 Months	Optics <sup>2</sup> (lens, mirror, beam combiner),

1... 12 month for 80 - 100 Watt laser tube, 18month on laser refill

2 ... No warranty for optics will apply, however, if such has to be replaced because of inadequate or incorrect cleaning (e.g. scratching during cleaning). Typical picture of optics damaged as a result of improper cleaning: shooting through the mirror or lens.

3... 12 month for water cooling unit

4... 48 month for Speedy package system

### Precondition for warranty

1. The commissioning and the user's training is performed by an authorized Trotec partner or by Trotec itself.
2. The machine is the property of the first user.
3. The user operates the machines in the environment as defined by Trotec (e.g. room temperature, fuse protection, etc.) as well as with a suction system supplied by Trotec. The predefined minimum requirements must be fulfilled when using any other suction system.
4. Immediate detailed notice of defects in writing to Trotec and/or the authorized Trotec partner.

### Content and scope of warranty

1. Defects that occur within the warranty period are remedied by Trotec by replacement of the defective parts. Exchanged parts become Trotec's property.
2. In the event of unrepairable relevant defects, Trotec shall have the right to avoid any claim to recede of the contract by effecting a gratuitous replacement.

### Exclusion of warranty

1. Improper commissioning and installation.
2. Improper operation or use, inadequate or improper maintenance, use of unsuitable accessories or operating material.
3. External influences, e.g. damage during transport, surges, damage to surface, damage by weathering or other natural phenomena.
4. Repairs or interferences by unauthorized third parties.
5. Use of not original Trotec spare parts.

# Operation Manual Trotec Speedy 300

## Miscellaneous provisions

1. Wels shall be place of performance and place of jurisdiction for all claims arising from the warranty obligation. Austrian law applies exclusively.
2. Trotec shall not assume any liability for loss of profit, turnover, goodwill or expected savings or for any direct or indirect damage or for claims made by third parties against the customer from use of, or the inability to use, the product.
3. In the event that individual provisions of the present warranty obligation should be or become legally ineffective for any reason whatsoever, then this shall not affect the validity of the other provisions herein.
4. In the case of warranty, both the costs for the part as well as the freight costs (standard freight) will be borne by Trotec.
5. In general the terms of businesses of Trotec are valid which you can see on the webpage [www.troteclaser.com](http://www.troteclaser.com).

Trotec Produktions- und Vertriebs GmbH  
Linzer Strasse 156  
A-4600 Wels, Austria  
email: [trotec@trotec.net](mailto:trotec@trotec.net)  
[www.troteclaser.com](http://www.troteclaser.com)

Effective from 8<sup>th</sup> of April 2005

## SECTION 2 – SAFETY

- 2.1 General Safety Information
- 2.2 Laser Safety Information
- 2.3 Safety Precautions when Operating the Device
- 2.4 Warning and Information Labels

# Operation Manual Trotec Speedy 300

# Operation Manual Trotec Speedy 300

## 2.1 General Safety Information

All personnel involved in installation, set-up, operation maintenance and repair of the machine, must have read and understood the Operation Manual and in particular the "Safety" section. The user is recommended to generate company-internal instructions considering the professional qualifications of the personnel employed in each case, and the receipt of the instruction/Operation Manual or the participation at introduction/training should be acknowledged in writing in each case.

### Safety-conscious Working

The machine must only be operated by trained and authorized personnel.

The scopes of competence for the different activities in the scope of operating the machine must be clearly defined and observed, so that under the aspect of safety no unclear questions of competence occur. This applies in particular to activities on the electric equipment, which must only be performed by special experts.

For all activities concerning installation, set-up, start-up, operation, modifications of conditions and methods of operation, maintenance, inspection and repair, the switch-off procedures that may be provided in the Operation Manual must be observed.

### Safety Information for the User and/or Operating Personnel

- No work methods are permitted that affect the safety of the machine.
- The operator must also ensure that no unauthorized persons work with the machine (e.g. by activating equipment without authorization).
- It is the duty of the operator, to check the machine before start of work for externally visible damage and defects, and to immediately report changes that appear (including behavior during operation) that affect the safety.
- The user must provide that the machine is only operated in perfect condition.
- The user must guarantee the cleanness and accessibility at and around the machine by corresponding instructions and controls.

# Operation Manual Trotec Speedy 300

## 2.1 General Safety Information

- Principally, no safety components may be removed or disabled (already here we emphasize the imminent dangers, for example severe burns, loss of eye-sight). If the removal of safety components is required during repair and service, the replacement of the safety components must be performed immediately after completion of the service and repair activities.
- Preparation, retooling, change of workpiece, maintenance and repair activities must only be performed with equipment switched off, by trained personnel.
- It is forbidden to perform unauthorized modifications and changes to the machine. It is emphasized, that any unauthorized modifications to the machine are not permitted for safety reasons.



# Operation Manual Trotec Speedy 300

## 2.2 Laser Safety Information



To assess the potential dangers laser systems pose, they are classified into 5 safety classes: 1, 2, 3a, 3b and 4. Speedy 300 is a device of **class 2 (USA: Class II)**. This is guaranteed by the protective housing and the safety installations.

Please note that improper operation of the device can override the status of safety class 2 and can cause the emission of harmful radiation.



This laser engraving system contains a carbon dioxide (CO<sub>2</sub>) laser of class 4, that emits ***intensive*** and ***invisible*** laser radiation. Without safety precautions the direct radiation or even diffuse reflected radiation is dangerous!



Without safety precautions, the following risks exist with exposure to laser radiation:

Eyes: Burns to the cornea  
Skin: Burns  
Clothing: Danger of fire



Never try to modify or disassemble the laser and do not try to start up a system that had been modified or disassembled!



**Dangerous radiation exposure can result from the use of operation or adjustment equipment other than that described here, and if different operational methods are performed.**



Service technicians using the service plug are required to wear standard laser safety glasses for CO<sub>2</sub> lasers (wavelength 10.6 μm).

# Operation Manual Trotec Speedy 300

## 2.3 Safety Precautions when Operating the Device

In your Speedy 300, a closed safety system is integrated which immediately switches off the power to the laser tube when the protection cover is opened. Consequently an incomplete engraving can occur if the cover is opened during operation. Therefore, first press the "PAUSE" button, if you want to interrupt an engraving process.

Please remember the following safety precautions when working with this device:

A fire extinguisher must always be handy as the laser beam can ignite flammable materials. Do not store any flammable materials in the inside of the device or in the immediate vicinity of the device.

### **Unsupervised operation of the system is not permitted.**

Because of their low absorption many metals, in particular un-coated aluminum, copper, silver and gold cannot be processed with the laser engraver and lead to high reflections of the laser beam. Such materials must not be inserted into the beam, as a directed reflection could destroy the protection cover.

Adjustment of the beam path must be performed only by especially trained personnel. An improper setting can lead to uncontrolled emission of the laser radiation.

Before processing materials the user must verify, whether harmful materials can be generated and whether the filter equipment of the exhaust system is suitable for the harmful materials. We emphasize that it is the responsibility of the user, to consider the national and regional threshold values for dust, fogs and gases when selecting the filters and the exhaust system. (The values for the maximum workplace concentration must not be exceeded.)

Please refer to the manual of the exhaust system on how and in what intervals you need to replace filters.

PVC (polyvinyl chloride) must under no circumstances be processed with the laser engraver.

Should you have further questions before starting work, please contact your dealer or TROTEC.

# Operation Manual Trotec Speedy 300

## 2.4 Warning and Information Labels



The warning and information labels are attached in such positions of the device that could represent a source of danger during set-up and operation. Therefore, follow the information on the labels. If labels are lost or damaged, they must be replaced immediately.

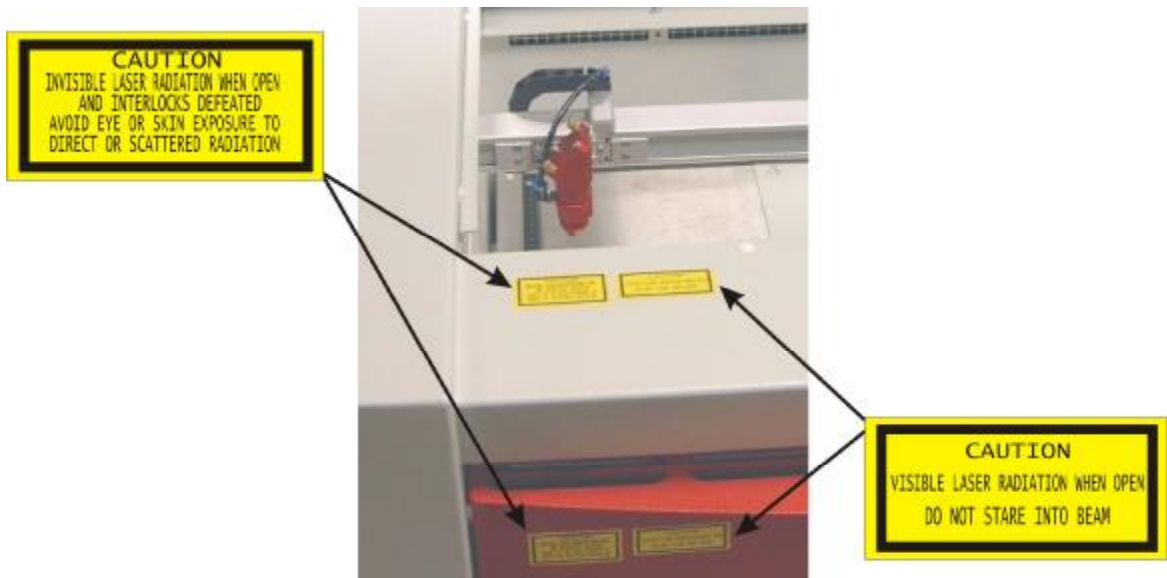
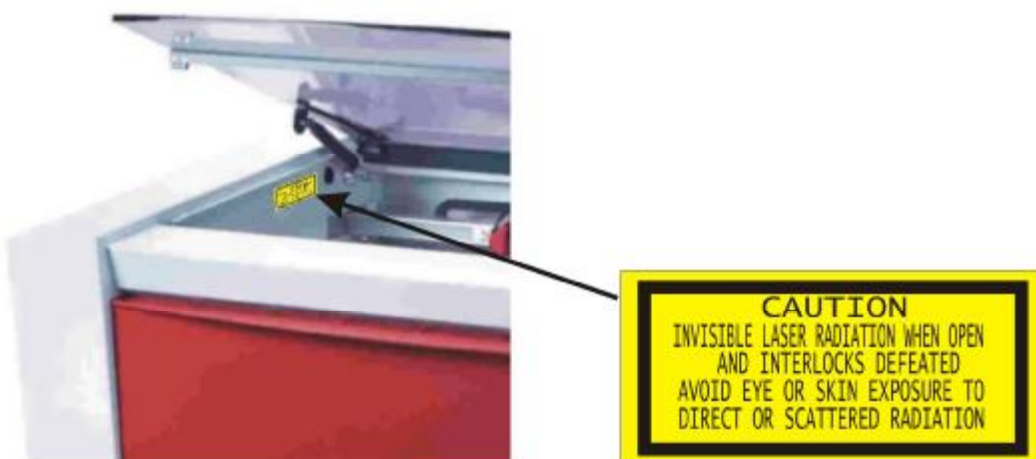

Figure 2



# Operation Manual Trotec Speedy 300

## 2.4 Warning and Information Labels

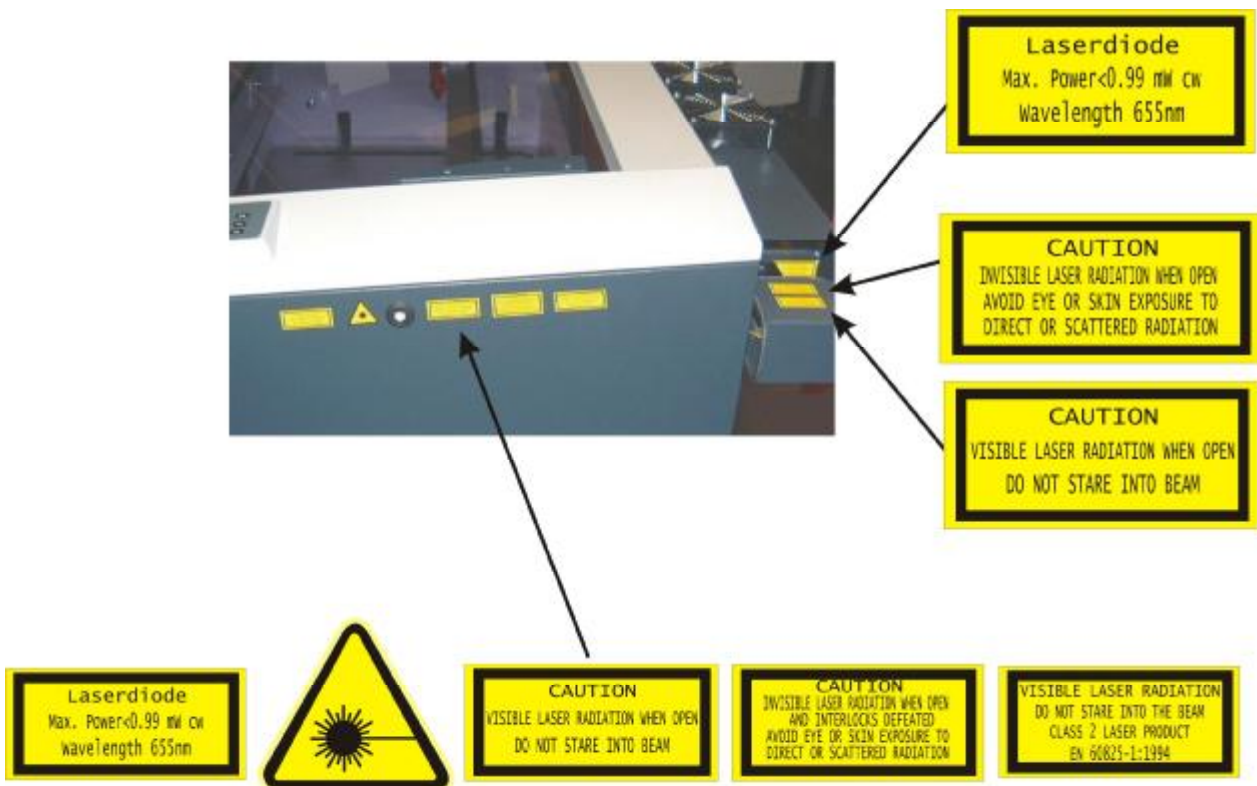
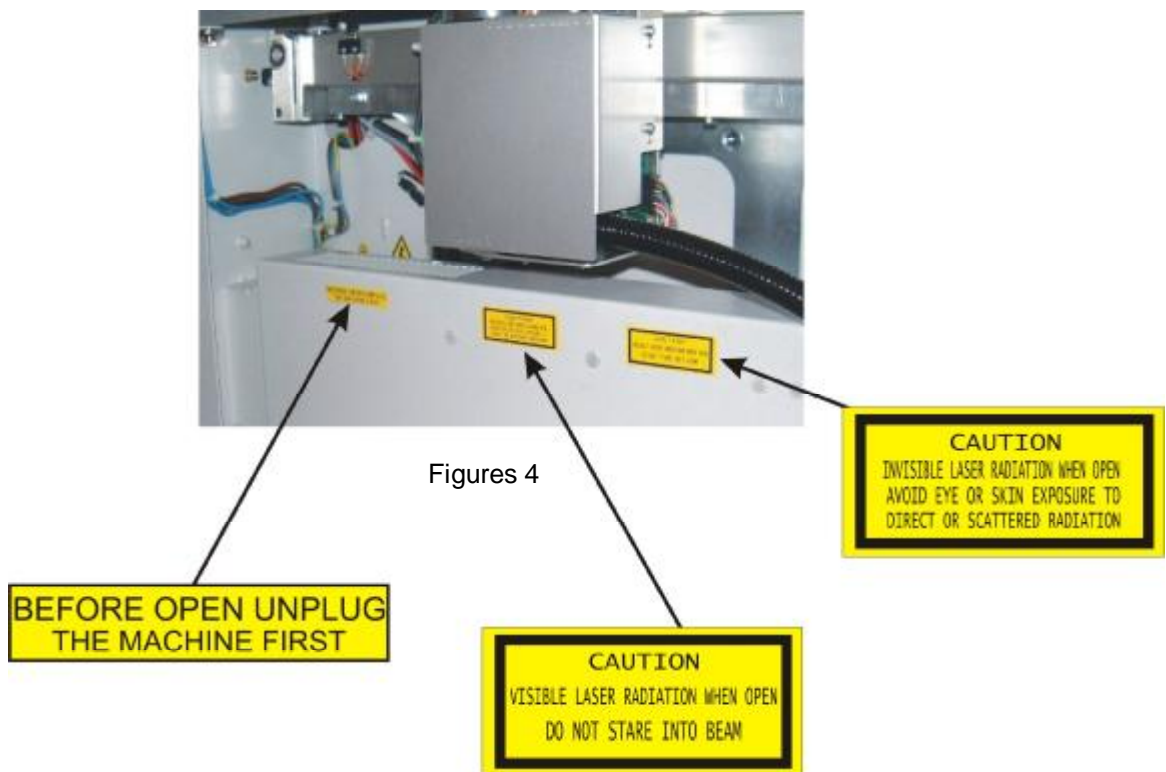
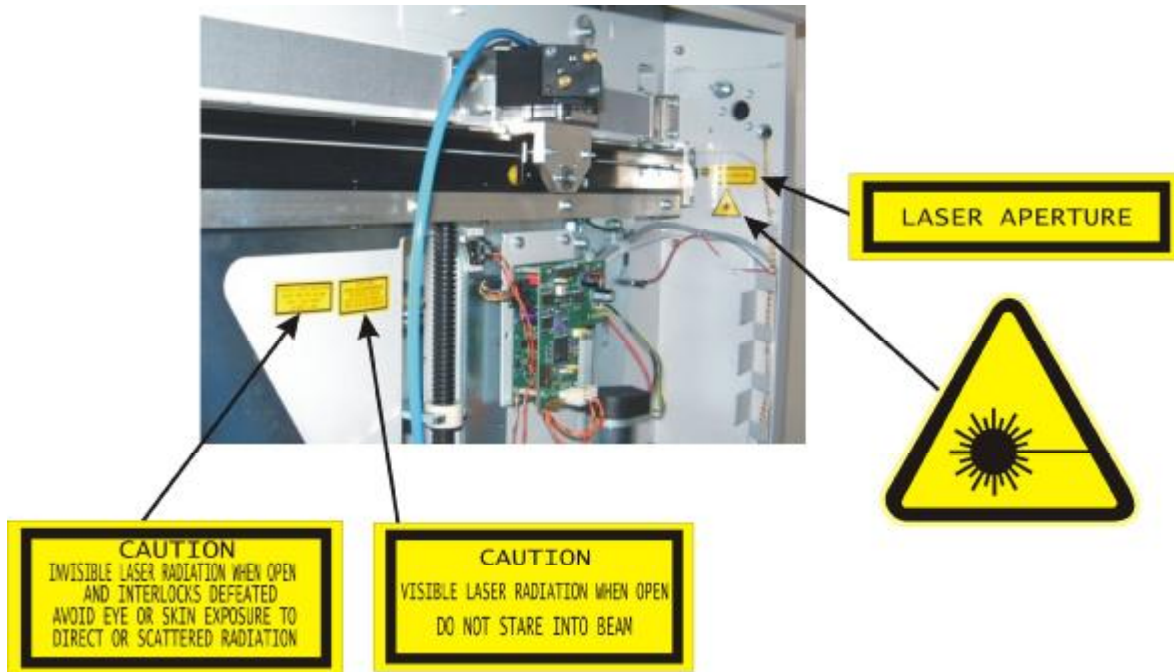

Figure 3

# Operation Manual Trotec Speedy 300

## 2.4 Warning and Information Labels



## SECTION 3 – BEFORE OPERATION

- 3.1 Unpacking the Speedy 300
- 3.2 Contents of Delivery
- 3.3 Location
- 3.4 Exhaust System – Requirements/Connection
- 3.5 Cooling System – Requirements/Connection
- 3.6 Computer Requirements
- 3.7 Connection of the Speedy 300

# Operation Manual Trotec Speedy 300

## 3.1 Unpacking the Speedy

You receive your Speedy 300 packed in a box, that contains the laser and additional accessories. The following steps give you an overview of the unpacking and assembly of the laser. Please follow these steps carefully.



Keep the packing box. You will require it in case of a return.

1. Remove the cover. Please do not forget to store this box in a dry place.

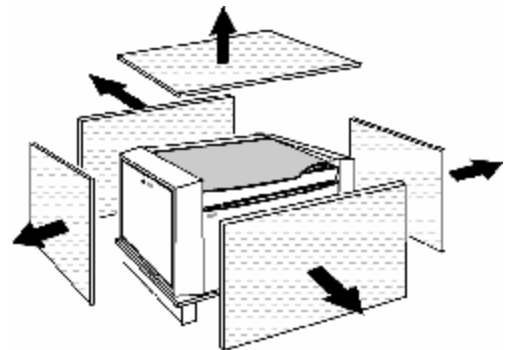

Figure 5

2. Carefully remove the foam material, which protects the viewing window of the cover, and the tape that holds this cover in place.

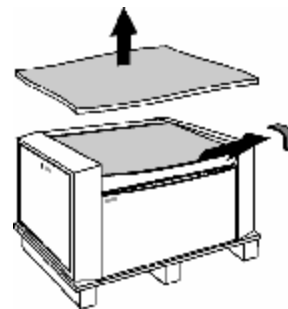

Figure 6

3. Open the front door and remove the accessories box located under engraving table, which contains all accessory parts required for the installation of the laser engraver.

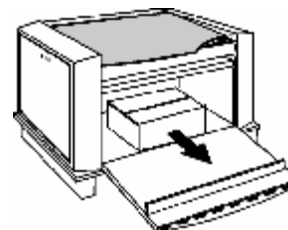

Figure 7

# Operation Manual Trotec Speedy 300

## 3.1 Unpacking the Speedy 300

4. Lift the laser engraver out of the box.  
For this you will require two persons.  
Position the laser engraver on a stable table or the delivered stand (optional).

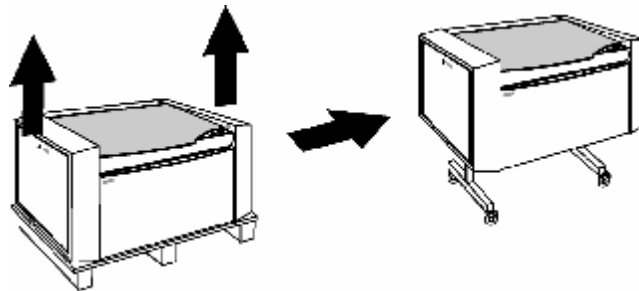

Figure 8

5. Open the accessories box.

## 3.2 Contents of Delivery

- Transport and service packaging
- Laser engraver including all optics
- Stand
- Accessories box, which contains the following parts:
  - Operators manual on CD also including:
    - TROTEC Manager software/Engraver driver software (1)
    - Lens cleaning tissues / Optics cleaning liquid (2)
    - Mains cable (3)
    - Computer connection cable (4)
    - Focussing gauge 1.5" (6)
    - Allen key set 1.5 - 10 mm (7)
    - Screws for assembly (9)

# Operation Manual Trotec Speedy 300

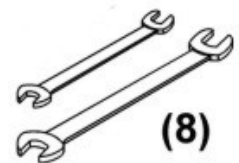
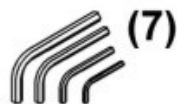
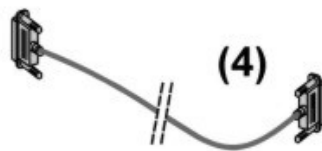
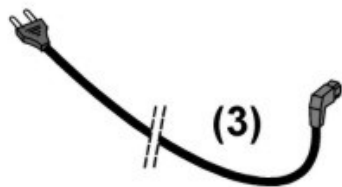
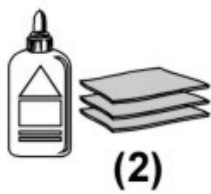

Figure 9

# Operation Manual Trotec Speedy 300

## 3.3 Location

Before you install the laser system, you should select an appropriate location. Follow the guidelines shown below:



Avoid locations where the system is exposed to high temperatures, dust and high humidity. (The humidity must not exceed 70% and the temperature must not be close to the dew point.)



Avoid locations, where the system is exposed to mechanical shocks.



Fuse protection:.

Do not connect other devices via the laser fuse, as the laser engraver system requires the full amperage.



Avoid locations with poor air circulation.



Select a location, whose room temperature is between 15 °C and 25 °C. Avoid higher ambient temperatures and strong exposure of the engraver to the sun. Use blinds, if required.



Select a location close to ventilation (if available).



Select a location that is not more than 2.50 m away from your computer (max. cable length to avoid disturbing interferences).



Try to place a working table or a place to put things next to it. This shall avoid, that the Speedy 300 is misused as a table.

## Operation Manual Trotec Speedy 300

### 3.4 Exhaust System – Requirements



To guarantee the right ventilation during the engraving of rubber, an exhaust system with a suction power of minimum **300 m<sup>3</sup>/h** is required. The device must be equipped with a fine dust filter (generation of rubber dust) as well as an activated carbon filter (neutralization of smells). A good filtering of the outgoing air is also required when cutting plastics or engraving wood. If only elox plates are engraved, the suction power can be reduced.

Connection - see section 3.7.3



Do not start the Speedy 300 without an adequate exhaust system.

### 3.5 Cooling System – Requirements



To achieve sufficient cooling of the laser tube, the Speedy 60 W and 100 W require the installation of a cooling aggregate.

Connection - see section 3.7.4

### 3.6 Computer – Requirements



The following recommendation represents the **minimum requirements**. When using a more powerful computer the graphics are generated and displayed faster and the computing times and the data transfer to the laser are reduced.

- Pentium 2000 or more powerful PC-compatible computer
- 128 MB RAM
- 60 GB hard disk
- a CD drive
- VGA color monitor
- mouse
- 1 free serial (RS232) interface for the laser engraver
- Microsoft Windows 95®/98/XP/ME/2000/NT
- Windows-compatible graphics software (ACAD, Corel Draw version 9 or higher or equivalent)

# Operation Manual Trotec Speedy 300

## 3.7 Connecting the Speedy 300



Perform the connections exactly in the order described, otherwise electrostatic charging can damage your computer and/or die electronics of the laser system.

### 3.7.1 Connecting the Mains

Connect one end of the mains cable with the connection socket at the rear side of the laser device (see Figure below) and the other end with a protected power outlet.



Mains voltage and operating voltage must correspond (AC 230 V/50 Hz or AC 115 V/60 Hz) – see information label beside the connection socket.

Under no circumstances switch on the device if the voltages do not correspond.



Figure 10

**INPUT POWER**  
220-240VAC, 3.6A, 50Hz



The main fuses of the Speedy 300 are located inside the connection socket and are accessible from the exterior.

# Operation Manual Trotec Speedy 300

## 3.7 Connecting the Speedy 300

### 3.7.2 Connecting the Computer



The computer must be connected to the mains voltage and switched off.

Connect the laser engraver (see Figure below) to a free serial interface on your computer. For this use the cable and, if required, the adapter from the accessories box.

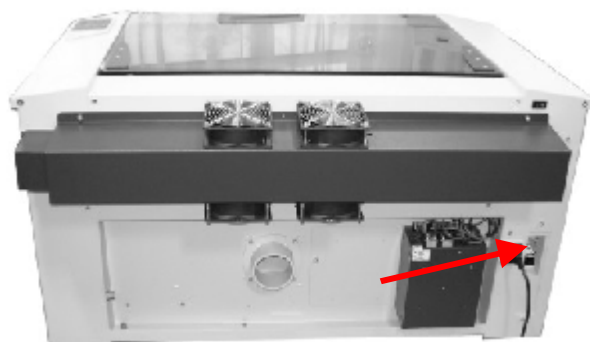

Figure 11

# Operation Manual Trotec Speedy 300

## 3.7 Connecting the Speedy 300

### 3.7.3 Connecting the Exhaust System

- Connect your exhaust system to the mains socket (1).



Make sure that the mains voltage corresponds with the voltage allocated for the exhaust system.

Plug the ends of the exhaust duct into the allocated connection (2).

- When using the TROTEC exhaust system, also connect it with the cable included to the remote control connector of the Speedy 300 (3).

Also follow the operation and maintenance instructions in the Operation Manual of the exhaust system.



Figure 12, cable connections

# Operation Manual Trotec Speedy 300

## 3.7 Connecting the Speedy 300

### 3.7.4 Connecting the Cooling System



The installation of the cooling system – for cooling of the laser tube – is only required for the Speedy 300 60 W and 100 W. These instructions are valid only for CFT models. For all other versions please check your chiller manual

1. Connect the cooling system to the mains voltage.



The mains voltage must correspond with the voltage specified on the cooling system.

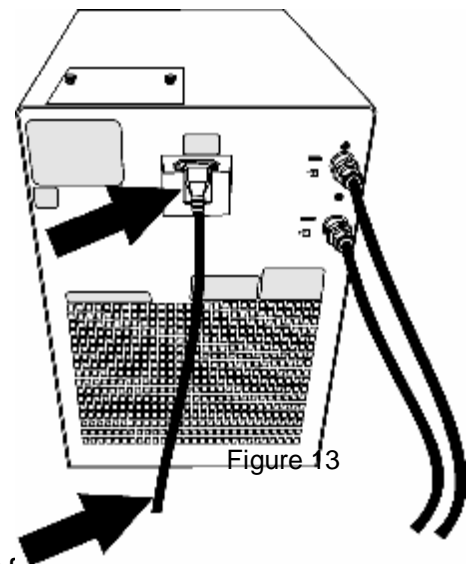

Figure 13

2. Two hose connections are located on both the left-hand side of the laser tube as well as rear side of the cooling system. Plug the two hoses, which were included in the delivery, into these connectors.

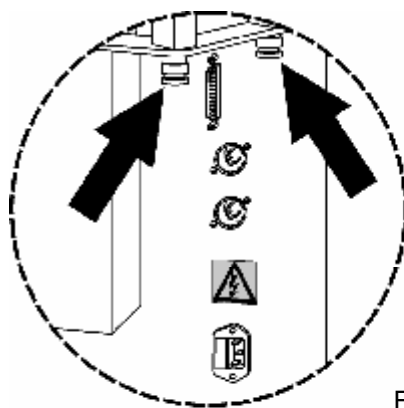
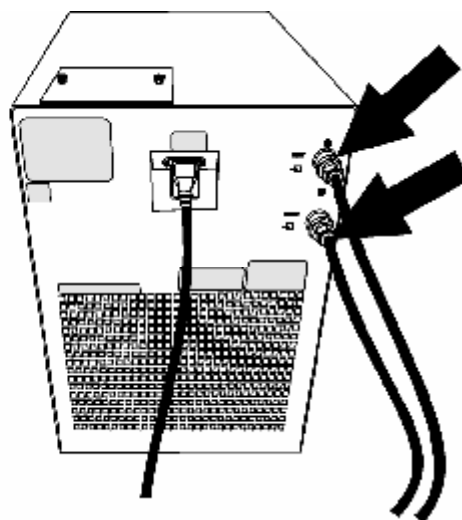

Figure 14



In this case the arrangement of the hoses is unimportant, because it is a closed system.

# Operation Manual Trotec Speedy 300

## 3.7 Connecting the Speedy

### 3.7.4 Connecting the Cooling System

3. To fill the reservoir, perform the following instructions:

- Undo the two screws (1) at the protection cover and remove the protection cover (2).
- Open the plug of the reservoir (3) and fill the reservoir with **distilled water**. The capacity of is approx. 4.3 liters.

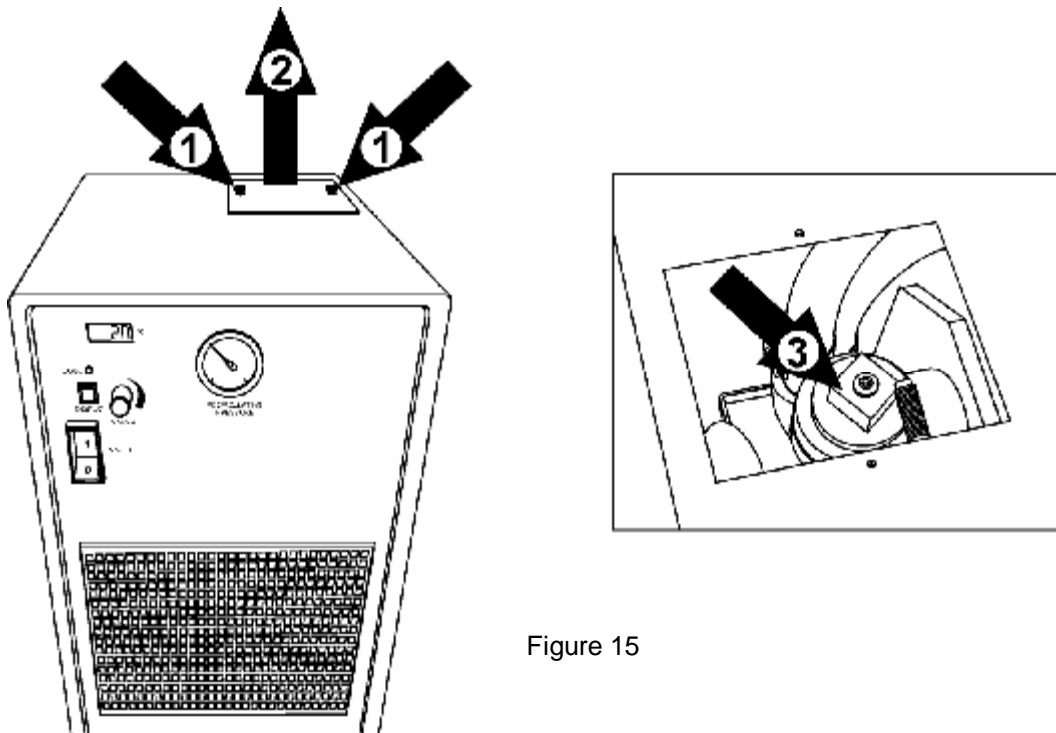

Figure 15



The 4.3 liters capacity is an approximate value.

Fill the reservoir until the water level is approx. 3 cm below the upper edge of the filler neck. Shake the cooling system from time to time during the process of filling and refilling, this guarantees that, the water fills correctly. The water level must be checked regularly.

Subsequently refit the plug of the reservoir and the protection cover.

# Operation Manual Trotec Speedy 300

## 3.7 Connecting the Speedy

### 3.7.4 Connecting the Cooling System

4. To set the temperature perform the following steps:

- Switch on the cooling system by setting the main switch (1) to "ON" (the switch is illuminated, when the device operates).
- Set the desired temperature. To do this, press the "Display" switch (2), hold the switch in, and simultaneously turn the "Adjust" switch (3) until "20°" appears on the display (4). When the temperature is set, release the "Display" switch.
- The actual temperature of the cooling liquid in the reservoir is shown on the display (4). Do not set the desired temperature to a lower value or condensation on the optics of the laser tube may occur.

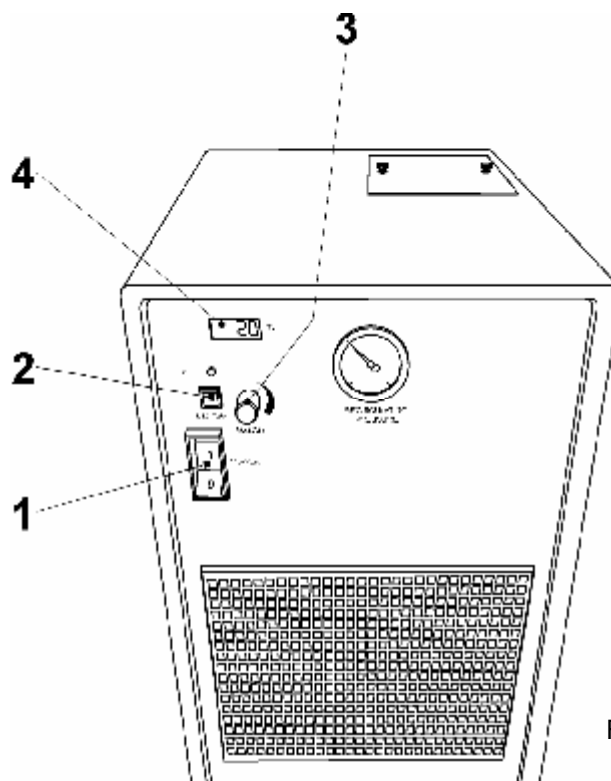

Figure 16



For information on cleaning, maintenance and other information please refer to the Operation Manual of the cooling system.



## SECTION 4 – OPERATION

- 4.1 System View / Assemblies and Control Elements
- 4.2 Control Panel
- 4.3 First Steps Before Engraving
- 4.4 First Engraving Tests
- 4.5 Rotary Engraving Attachment
- 4.6 Tips and Tricks for Laser Engraving

# Operation Manual Trotec Speedy 300

## 4.1 System View / Assemblies and Control Elements



Figure 17

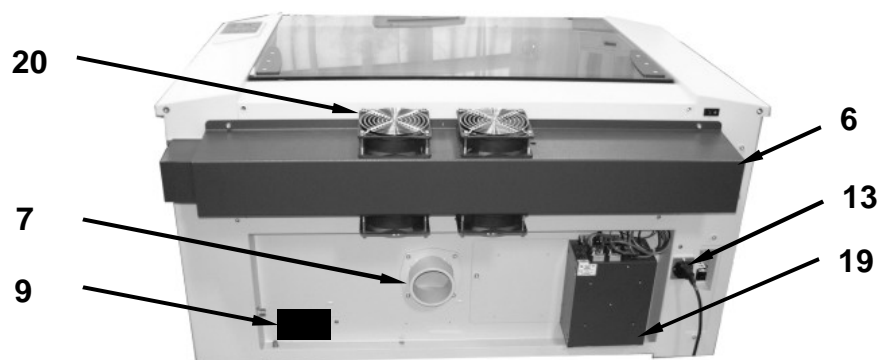

Figure 18

- |   |                              |    |                           |
|---|------------------------------|----|---------------------------|
| 1 | autofocus sensor             | 10 | X-axis                    |
| 2 | focussing head               | 11 | keypad                    |
| 3 | engraving table              | 12 | ruler                     |
| 4 | Connection Socket for Rotary | 13 | power socket              |
| 5 | Polycarbonate door           | 14 | service access panel      |
| 6 | Laser tube cover             | 16 | right interlock front lid |
| 7 | Exhaust connector            | 18 | maintenance panel         |
| 8 | service socket               | 19 | Power supply              |
| 9 | Product ID label             | 20 | Cooling fan               |

# Operation Manual Trotec Speedy 300

## 4.1 System View / Assemblies and Control Elements

### 08 Service Socket



Used for the service plug, which is required for maintenance and adjustment work.



This service plug bypasses the safety installations and the laser engraver becomes laser class 4. Bypassing is only by authorized personnel.

### 01 Light Barriers



Used for the automatic focussing of the workpiece.

### 02 Focussing head



The lens that focuses the laser beam onto the material is mounted inside the focussing head.

### 03 Engraving Table



The workpieces to be processed are put onto the engraving table. To facilitate orientation, a horizontal and a vertical ruler are located on the engraving table.

### 04 Connection Socket for Rotary Engraving Attachment



Connector for the rotary engraving attachment (option).  
Supplies the rotary engraving attachment with the required electric signals.

# Operation Manual Trotec Speedy 300

## 4.1 System View / Assemblies and Control Elements

### 05 Protection Cover



If the protection cover is opened, no data is processed. After closing the protection cover, the device is not ready to process commands for 5 seconds. If the protection cover is opened during operation, the motion system is stopped. The device switches into "Pause" mode, the "Pause" button lights up. The last processed command is completed.



Please note, that the laser tube is switched off **immediately** and consequently the result of the engraving is incomplete. During processing of commands the protection cover must only be opened after pressing the "Pause" button.

### 06 Laser Tube



The laser tube is mounted under a cover profile with 4 cooling fans.

### 07 Exhaust System Connection Sleeve

### 09 Manufacturer's Label

### 10 X axis



The motion system is that part of the Speedy 300 that performs the mechanical movements in X direction (horizontal) and Y direction (vertical). The X axis is visible in the engraving area.

### 11 Control Panel



The Control Panel contains multiple buttons and displays for controlling the device.

# Operation Manual Trotec Speedy 300

## 4.1 System View / Assemblies and Control Elements

### Front Door



If the front door is opened, no data is processed. After closing the front door, the device is not ready to process commands for 5 seconds. If the front door is opened during operation, the motion system is stopped. The device switches into "Pause" mode, the "Pause" button lights up. The last processed command is completed.

# Operation Manual Trotec Speedy 300

## 4.2 Control Panel

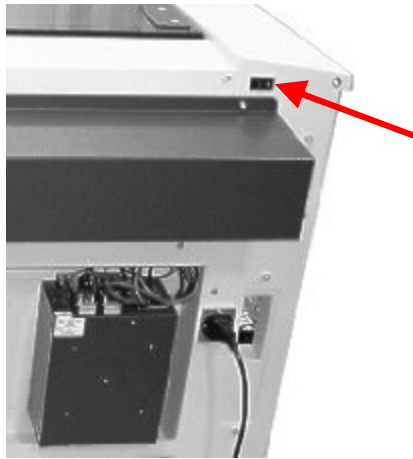

Figure 19, on/off switch

### ON/OFF Switch

Switches the mains supply ON/OFF.

The following conditions must be fulfilled for correct start up:

- unrestricted freedom of motion of the mechanics
- no materials under the engraving table
- protection cover closed
- service plug removed

If the service plug is plugged in or the protection cover is open, an acoustic signal sounds and the status display (10) flashes fast in green.

Immediately after being switched on, the device starts the referencing process. If the referencing process is completed correctly, an acoustic signal sounds and the device is ready for operation. The readiness for operation is additionally displayed by green (slow) flashing of status display (10).



Before switching on the device, the user must make sure that no objects of any kind are located inside the operating space, which could limit or obstruct the mechanics of the device.



When switching off the mains supply, all processing data is lost.

# Operation Manual Trotec Speedy 300

## 4.2 Control Panel

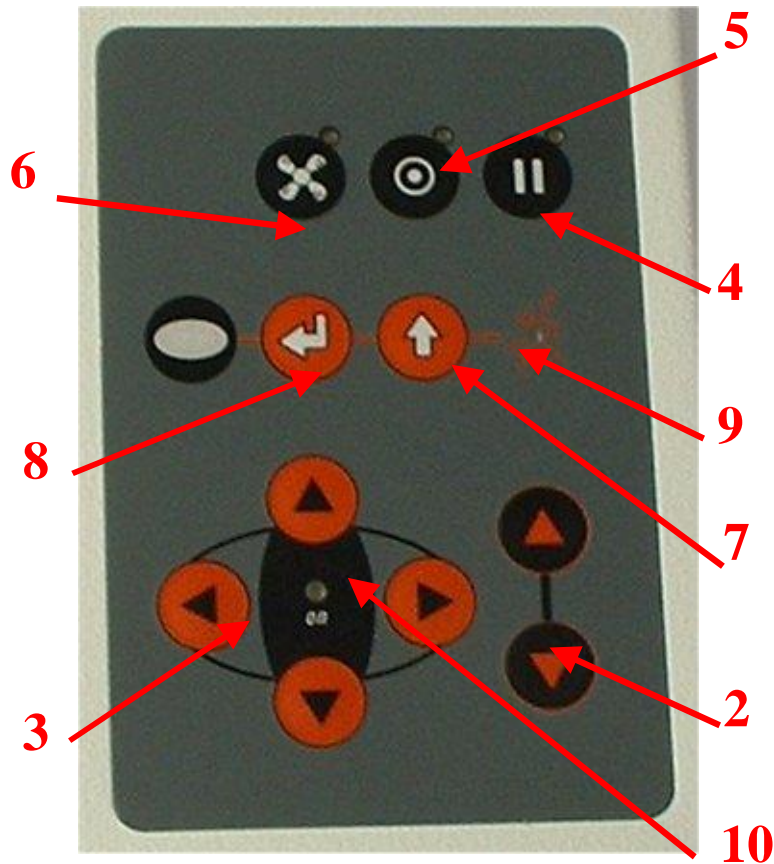

### 2 POSITIONING KEYS Z

When pressing one of these two keys the engraving table moves in Z direction (upwards or downwards).



Use these positioning keys to move the workpiece manually.

When both keys are pressed simultaneously, the material is focussed automatically (only with light barriers = option).

Before the autofocus- move is started, the head is moved backward in line with the light barriers to detect whether a longer nozzle is mounted to the head or not. If so, the upward move is suppressed to prevent a collision with the nozzle and the table.

By pressing the “Test” key and a Z- positioning key an automatic move to the corresponding end- positions is performed:

## Operation Manual Trotec Speedy 300

Test + Down: the table moves down to the lowest possible position

Test + Up: the table moves up to the autofocus- position.

Note: Test + Up will cause the "nozzle test movement" (head moves backward).

If any of positioning keys X and Y are pressed, no moves in Z are possible.

**An automatic move of the Z- axis can be stopped by pressing any of the Z- axis keys (Up / Down).**

### 3 POSITIONING KEYS X/Y

Use the positioning keys to manually move the lens holder into the indicated directions.



When you press two keys simultaneously, the lens holder moves diagonally.

When you press the "Test" keys and one of the positioning keys simultaneously, a movement to the corresponding end position is performed.

If all panels are closed, the movement is done with the maximum possible velocity, if opened, the speed is 1/4<sup>th</sup> of the maximum.

While the Z- axis is in movement (eg. autofocus), no cursor moves in X and Y axis are performed.

The status display of the device is located in the center of the key pad.

### 4 PAUSE



Used to stop the current working process (key lights up).

If this key is pressed a second time, the key illumination goes out, the interrupted working process is continued.

# Operation Manual Trotec Speedy 300

## 4.2 Control Panel

### 5 STANDBY



Switches the device into Standby mode (Laser ready, illumination off) – key lights up.

By pressing the key again the device is switched back to Ready mode.

If the Standby button is pressed while the Z- axis is in an automatic move (eg. autofocus), the Standby mode is entered after finishing the Z- axis- move (Z- axis move can be stopped by pressing any of the Z- axis keys).

### 6 EXHAUST



Used to manually switch the exhaust system on and off.

The key illumination shows the status of the exhaust system. When the key is illuminated, the exhaust system is switched on.

After completing the engraving process, the exhaust system can only be switched off after some seconds (after running time).

### 8 REPEAT (SERVICE)



By pressing repeat, the jobs which are currently positioned on the selected plate in the Trotec manager are started.

If the jobs have been processed before, they will be reset automatically.

# Operation Manual Trotec Speedy 300

## 4.2 Control Panel

### 7+ 8 TEST / REPEAT (SERVICE)



The keys "Test" and "Service" pressed simultaneously fire a laser test pulse. This is used for maintenance and only works with the door closed or with the service plug defeating the interlocks.



As in this case an increased danger of laser radiation exists, an acoustic signal sounds.

### 9 STATUS INDICATOR LASER BEAM



Indicates, that a laser beam is currently being emitted.

### 7+ 4 TEST / PAUSE

By pressing test+pause the buffer memory in the machine is emptied.

### 10 STATUS DISPLAY (indicates the current status of the device):

green, flashing slowly (0.5 Hz)	<b>10</b>	Speedy 300 is ready
green, flashing fast (2 Hz)	<b>10</b>	Cover has been opened
green permanent light / Pause mode	<b>10</b>	Data available in the Speedy 300
red permanent light	<b>9</b>	Laser beam is being emitted
green/red flashing alternately	<b>9</b> <b>+</b> <b>10</b>	Cover open during switch-on process, simultaneously acoustic signal - no referencing

# Operation Manual Trotec Speedy 300

## 4.3 First Steps Before Engraving

To prepare your laser engraver for the first engraving tests, perform the following steps:

1. Switch Speedy on with the ON / OFF switch.

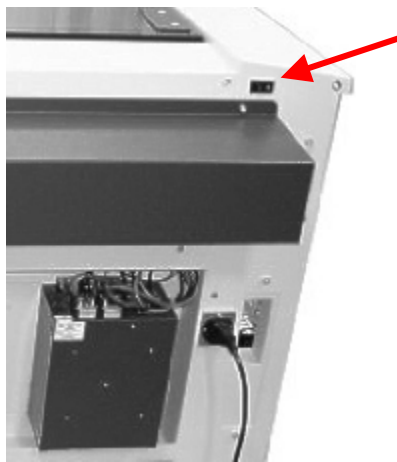

Figure 20

2. The working table automatically references in X/Y/Z direction.
3. Open the protection cover and place workpiece on the engraving table.



Usually you position the workpiece into the upper left-hand corner of the engraving table against the horizontal and vertical rulers. However, any other position on the engraving table is also possible.



Workpieces, that are larger than 730 x 436 mm, can be processed provided they can be installed and the protection cover can still be closed properly. Do not try to manipulate the safety system to install larger workpieces on the system. This could lead to exposure to laser radiation.

# Operation Manual Trotec Speedy 300

## 4.3 First Steps Before Engraving

### 4. Focussing the Laser Beam

For the laser beam in your laser system to be able to engrave and cut precisely, the energy is focussed with a lens system, which is mounted on the motion system in a lens holder.



The focussing point of the laser beam (for the high-resolving lens, that is part of the delivery) is located 3.81 cm (1.5 inch) below the lens.

For optimal processing the surface of the material that you want to engrave or cut, must be adjusted to this point.

There are three methods to focus the laser beam:

- A:** Manual focussing
- B:** Focussing by software
- C:** Automatic focussing by means of light barriers

To **A** – Manual focussing:

- A1. Move the processing head over the material to be engraved by means of the positioning keys X/Y



Figure 21: height adjustment via Z positioning keys

# Operation Manual Trotec Speedy 300

## 4.3 First Steps Before Engraving

- A2. Hang the focussing tool on the external ring of the working head so that the focussing tool can move unhindered. Move the working table upwards by pressing the Z positioning key. While doing this carefully observe the focussing tool.



Figure 23

Before the focussing tool reaches the workpiece, move the working table upwards only very slowly and step by step by briefly tapping the positioning key, until the tool tilts to the side. Now the lens is focussed onto the surface of the material.

# Operation Manual Trotec Speedy 300

## 4.3 First Steps Before Engraving

To **B** – Focussing by software:

- B1. Click the icon “focus laser” in the Trotec manager  
The working table moves in Z direction, The thickness of the material, that was entered, is used as target value for the focussing (see also description of the software).

To **C** – Automatic focussing by means of light barriers:



The automatic focussing is only possible if the workpiece is thicker than the rulers.

- C1. By pressing the two keys for Z positioning of the working table simultaneously, the laser beam is automatically focussed onto the workpiece.



Figure 25

# Operation Manual Trotec Speedy 300

## 4.4 First Engraving Tests

The following steps describe, how to successfully engrave a first pattern. Please follow the individual steps:

1. First switch on the computer, then the Speedy.

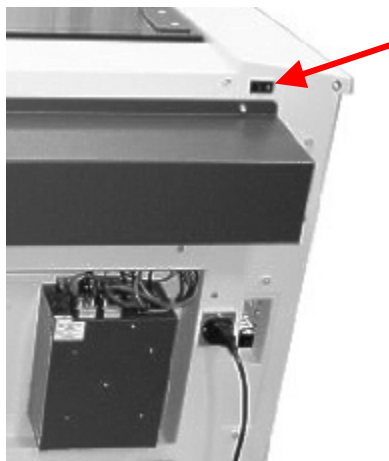

Figure 26

2. Put the object to be engraved into the laser and move into the desired position on the engraving table. Usually the object is positioned in the upper left-hand corner. Use the rulers to determine the dimensions of the object to be engraved.
3. With the positioning keys the lens is positioned over the material to be engraved. You focus with the help of the focussing tool or by auto focus (see pages 41-43).



Figure 28

# Operation Manual Trotec Speedy 300

## 4.4 First Engraving Tests

4. Generate a graphic with the help of your graphics software. The size of the graphic does not matter as the printer driver adjusts it to the workpiece automatically if requested.



Pos. 5 – 7 and 12 also see Operation Manual Part B – Software

5. Select "File Print", to access the Speedy 300 printer driver, where you can perform workpiece and material settings as well as specify a job name or a job number. This file is automatically transferred into the TROTEC Manager.
6. After the engraving material, the engraving direction, die orientation of the workpiece and the orientation of the plate have been specified in the TROTEC Manager under "Plate, Setup Plate", the job can be positioned on the plate with a double-click. If necessary, the job can be positioned at any position on the plate by dragging with the mouse. The position of the job corresponds with the engraving position on the engraving table.  
**Make sure that on engraving flammable materials the air assist is on!**
7. Establish a connection with the engraver by clicking on the button "Establish Connection" in the Engraver Control.
8. Switch on the exhaust system. When using an original TROTEC exhaust system, this happens automatically – check only, whether in the indicator "Exhaust Ready" is green in the Engraver Control of the Manager.
9. If you have a Speedy 300 with a 60 W or 100 W laser tube, also switch on the cooling system.
10. Finally press the START button (green arrow) in the Engraver Control of the Manager, to start the engraving process.
11. While the laser is engraving, you can generate the next graphic.
12. When the engraving is complete, the Manager offers you the following possibilities:
  - delete the job
  - Job Reset and placing back in to the waiting list for later repeat of the engraving.
  - Job Reset and immediate repeat

# Operation Manual Trotec Speedy 300

## 4.5 Rotary Engraving Attachment



The rotary engraving option in the Speedy 300 printer driver is used in combination of the rotary engraving attachment, to engrave cylindrical objects.

To compensate for the different diameters of different objects, the image must be adjusted. This is performed automatically by the engraving driver, by selecting the rotary engraving option and entering the diameter of the object to be engraved.



The rotary engraving attachment permits engraving of cylindrical object with a diameter of up to 175 mm and a length of up to 300 mm.

Two attachment parts are delivered with the rotary engraving attachment. A rubber cone that is attached to the motor side, and a metal cone that is attached to the adjustable side of the rotary engraving attachment. These attachment parts are designed to hold wine glasses, cups etc.

To install and set-up the rotary engraving attachment proceed as described as follows:

1. Move the working table to the lower position, switch off the laser and open the protection cover of the laser engraver.



Figure 29

## Operation Manual Trotec Speedy 300

### 4.5 Rotary Engraving Attachment

2. Put the rotary engraving attachment onto the working table and connect the rotary engraving attachment to the working table. Before you fix the rotary engraving attachment, align it so that its sides are parallel to the rulers. The rulers offer a visual aid for placing the graphic.
3. Connect the rotary engraving attachment via the control cable with the connector of the Y axis of Speedy's motion system. The connector is located inside the left front of the interior under the engraving table (see Fig.).



Figure 30

# Operation Manual Trotec Speedy 300

## 4.5 Rotary Engraving Attachment

### Mounting the workpiece:

4. Before you mount the glass into the rotary engraving attachment, measure the diameter of the glass at the position to be engraved with a sliding caliper or a similar tool. Write down this value.
5. Press the open end of the glass against the left-hand side of the rotary engraving attachment. Loosen the lever (arrow) of the adjustable side of the device and move the device to the left, until the glass is held by both disks. Now fasten the lever at the adjustable end to fix the setting.

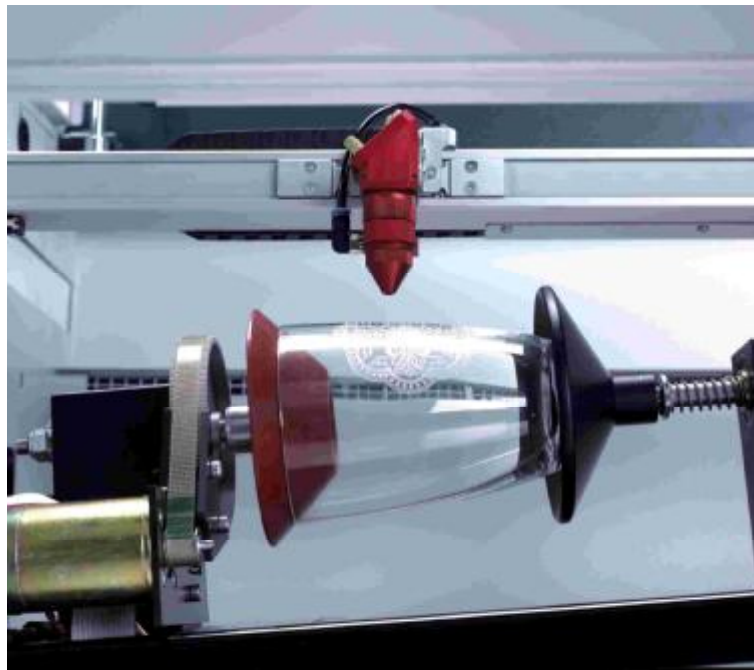

# Operation Manual Trotec Speedy 300

## 4.5 Rotary Engraving Attachment

6. Now switch on the laser and wait until the referencing is complete. Position the working head over the glass at the position, where you want to engrave. Now focus the object with the focussing tool. If the glass slopes too much in the area to be engraved, the rotary engraving attachment can be tilted, so that the surface of the glass is running again parallel with the X axis of the motion system. To do this, lift the right-hand side of the rotary engraving attachment and place a wedge under it. Take care not to lift the rotary engraving attachment too high, as it can touch the lens holder.

# Operation Manual Trotec Speedy 300

## 4.5 Rotary Engraving Attachment

### Engraving:



Pos. 8 – 14 and 17 see also Operation Manual Part B – Software

7. Generate a graphic with the help of your graphics software. The size is not important, as the graphic is adjusted to the dimensions of the workpiece by the printer driver.
8. Then perform the settings for size and orientation in the Manager under "Plate, Setup Plate" and, if necessary, select the engraving material. Please note especially, that you can determine the orientation of the graphic on the glass with "Stamp Orientation".
9. In the "Options" menu of the Manager select "Rotary Engraving Attachment" and enter the diameter of the glass.
10. Place the previously generated engraving job into the waiting list with a double-click.
11. Use the mouse to drag the job to the position of the plate, at which the desired engraving area is located on the glass. Use the rulers of the Speedy 300 and the Manager for orientation and move the lens holder directly over the desired position, after you have connected the computer with the laser engraver, and position the job on the screen according to the position of the lens.

# Operation Manual Trotec Speedy 300

## 4.5 Rotary Engraving Attachment

12. Establish the connection to the engraver.
13. Switch on the exhaust system (only necessary if you do not use an original TROTEC exhaust system).
14. If you have a Speedy 300 in 60 W / 100 W configuration, switch on the cooling system.
15. Activate the START button in the Engraver Control of the Manager and start the engraving process.

# Operation Manual Trotec Speedy 300

## 4.6 Tips and Tricks for Laser Engraving



The engraving depth can easily be varied through the laser power or the speed. To increase the engraving depth, reduce the speed or increase the power setting. This way you increase the amount of energy per area unit. Engraving too deep, however, reduces the quality of the details. With coated materials the required power depends of the kind and thickness of the coating. With power set too high the individual lines become too thick and a sharp picture cannot be achieved. The resolution of the graphics should usually be at 500 dpi. The dpi setting (number of laser dots per inch) depends on the material. The lower this setting is, the lower the resolution of the engraved picture will be. This, however, reduces flaming and increases the energy of a pulse, which can improve the overall result (e.g. when engraving some sorts of plastic materials).



### Protection foil:

Remove the protection foil from the engraving area. However, leave the protection foil on the area that is not engraved, to avoid scratching of the material.



### Plastics:

Plastics for engraving are available in many different colors and thicknesses and with many different coatings and surfaces. The majority of available plastics can be well engraved and cut with the laser. Plastics with a micro-porous surface seem to give the best result, because less surface material needs to be removed. As most plastic materials have a low melting point, a low ppi setting should be selected to reduce the danger of melting.

## Operation Manual Trotec Speedy 300

### 4.6 Tips and Tricks for Laser Engraving



#### Acrylic:

There are two different types of acrylic – cast and extruded. The cast acrylic becomes white or mat after engraving, the extruded acrylic remains clear. Use extruded acrylic for engravings that are filled with paint and cast acrylic for normal engravings. Cast acrylic can be best engraved without protection foil. It is better to engrave the entire surface with a low energy setting.



#### Engraving photographs:

Engraving photographs can be quite a challenge at the beginning. But as soon as you understand the basics it will become easier for you. Scan the desired picture with a resolution of 300 dpi. Adjust brightness and contrast so that lighter colors become lighter and darker colors become darker. The photo might look better if you use a filter, which sharpens the contours. The next step is the selection of a raster. Usually the software offers a selection of different rasters with a specified number of lines per inch and different raster angles. Use a raster with between 20 and 100 lines per inch. Increasing the number of lines per inch decreases the size of the points. Try which raster you think looks best. With one material large points look better, with another material smaller points look better. If you cannot select rasters with your software, the Speedy will select the raster automatically.

# Operation Manual Trotec Speedy 300

## 4.7 Tips and Tricks for Laser Cutting



### Distance to the Surface of the Workpiece

If you want to achieve very good results, when laser-cutting acrylic or wood, we recommend, that the plate be attached at least some millimeters above the engraving table. By doing this the smoke and the melting residuals underneath the plate can escape unhindered. A slight moistening of the plate will reduce the area of heat influence. Generally the protection foil should be removed, except when there is considerable development of fumes. During laser cutting the Hz setting (pulses per second) should be set to low, in particular for flammable materials.



### Multiple cutting (insert logo)

Often a clearer contour can be achieved by cutting twice rather than cutting only once.

# Operation Manual Trotec Speedy 300

## 4.8 Tips and Tricks for the Production of Rubber Dies



The various mixtures and densities of rubber plates cause a slightly varying engraving depth. The settings in the overview table give a good indication. Since engraving a standard rubber material requires a relatively high laser power, the laser power is principally set to 100% and only the speed is varied.

Due to their lower density, so-called microporous rubber materials allow a significantly higher engraving speed. Test the rubber first, to find out the correct speed setting.

The TROTEC Manager software simplifies the creation of a stamp significantly. Mirroring as well as converting is performed automatically and a cone-shaped shoulder is generated around each letter. Due to the wider base the letters are stabilized during stamping and therefore the imprint becomes clearer. If you engrave rubber dies without using this option, the letters will have no shoulders making them very thin and unstable.

To avoid flaming, we recommend a very low HZ setting for cutting the rubber die. If the Hz setting is further reduced, the laser pulses are set so far apart from each other that their edges just touch. This results in a perforation. The rubber die stays connected to the rubber plate but can be torn off easily. The advantage of this method is, that there is practically no further risk of deformation or melting of the material. Furthermore, the entire plate can be removed from the laser at one time instead of having to collect all dies individually.

Engraving rubber produces a considerable amount of dust. Therefore a well-dimensioned exhaust system and its regular maintenance are very important.

## SECTION 5 – MAINTENANCE

- 5.1 Cleaning the System
- 5.2 Cleaning the Optical Parts
- 5.3 Maintenance Plan

# Operation Manual Trotec Speedy 300

## 5.1 Cleaning the System



Caution – use of controls or adjustments or performance of procedures other than those specified herein may result in hazardous laser radiation exposure.



Before starting cleaning and maintenance work always switch off the device and unplug the mains plug.



You should check at least once a day, whether dust has accumulated in the engraving system. In case of soiling the machine must be cleaned.

The cleaning interval strongly depends on the material that is being processed and the operating time of the device. Please bear in mind that only a clean machine guarantees optimal performance and reduces the service costs.

### General Cleaning:

1. Move the engraving table into a position in which it is easiest for you to clean the surface with a window cleaning agent and paper towels.
2. Make sure, that the device is switched off and unplugged. Open the protective cover.
3. Thoroughly remove all loose dirt particles and deposits in the interior of the machine.
4. Clean the cover of the laser tube.
5. You can clean the viewing window with a cotton cloth. Do not use paper towels as they could scratch the acrylic.

# Operation Manual Trotec Speedy 300

## 5.2 Cleaning the Optical Parts

The lens has a durable multi-coating and cannot be damaged by correct and careful cleaning. You should inspect the mirrors and the lens at least once a week. If you discover a veil of haze or dirt, you must clean them.

Follow the instructions below for the cleaning of optical parts:

### CLEANING THE LENS

1. Move the engraving table to a distance approx. 10 cm under the lens holder.
2. Move the working head into the center of the working surface and put a cloth under the lens holder (so that the lens is not damaged if it accidentally falls out of its holder).
3. Now you can remove the lens by turning the fixing ring and pulling the lens assembly to the front.

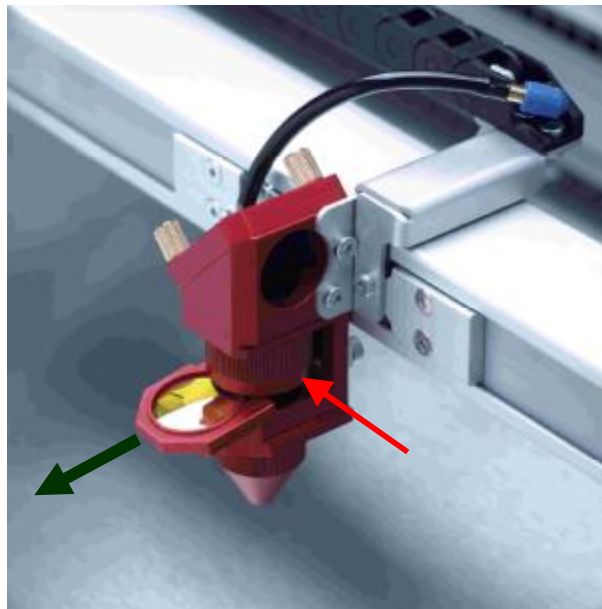

Figure 32: lens fixing ring

4. Remove the coarse dust by blowing air onto the lens surface.

# Operation Manual Trotec Speedy 300

## 5.2 Cleaning the Optical Parts

5. Hold the lens assembly by its edge with a lens cleaning tissue and use a drop of lens cleaning liquid from the little bottle which you received as an accessory delivered with the laser. While holding the lens on an angle, flush both surfaces of the lens, to wash away coarse soiling.
6. Put the lens on a clean lens cleaning tissue. Put some lens cleaning liquid on one side of the lens. Leave the liquid to take effect for approximately one minute and then gently wipe it away with lens cleaning tissues soaked with lens cleaning liquid.
7. Finally, dry this side of the lens with dry lens cleaning tissues and repeat the cleaning process on the other side of the lens.



Never use a cleaning tissue twice. Dust accumulated in the cleaning tissue could scratch the lens surface.

8. Examine the lens. If it is still soiled, repeat the cleaning process until the lens is clean.
9. Carefully insert the lens into the lens holder.



Ensure, that the rounded side (= convex) of the lens is facing upwards

10. Carefully assemble the lens in reverse order.

# Operation Manual Trotec Speedy 300

## 5.2 Cleaning the Optical Parts

### CLEANING THE MIRRORS #2 AND #3



There are two mirrors in the operating area of the laser, which may have to be cleaned if they are soiled. To clean the mirrors, follow the instructions below.

#### MIRROR #2

1. The mirror #2 is located on the right-hand side of the Speedy 300. To be able to access mirror #2, you must remove the right maintenance panel.



The laser must be switched off before the facing is removed !

2. The mirror #2 is attached by means of two allen screws (arrow), which are located on the mirror holder. Open the screws and remove the lensholder together with the mirror.



Make sure that you do not touch the mirror surface with your fingers as this reduces the mirror's working life significantly.

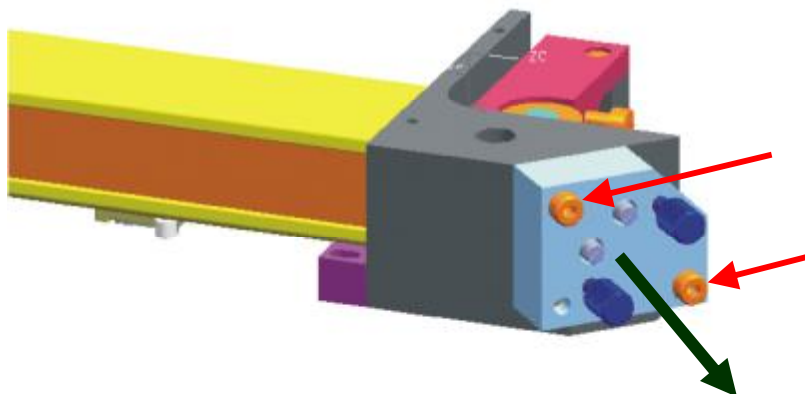

Figure 33

# Operation Manual Trotec Speedy 300

## 5.2 Cleaning the Optical Parts

3. Use a drop of lens cleaning liquid from the accessories box and, while holding the mirror on an angle, flush the surface of the mirror, to wash away coarse soiling.
4. Put the mirror on a working surface. Put some drops of lens cleaning liquid on the mirror and leave the liquid take effect for approximately 1 minute.
5. Use a folded piece of lens cleaning tissue soaked with lens cleaning liquid and wipe gently over the mirror only once. Use a fresh lens cleaning tissue soaked with lens cleaning liquid each time and again wipe over the mirror only once. Then wipe the mirror dry with a new dry lens cleaning tissue. Never use a cleaning tissue twice, as it could carry dust particles, which can scratch the mirror surface.
6. Examine the mirror and repeat the cleaning process, if necessary.

### MIRROR #3

1. While holding the mirror, loosen the two knurled screws (1) and lift the mirror from the mirror holder (2).



Pay attention that the mirror doesn't grind over the mirror holder, as it can be scratched very easily.

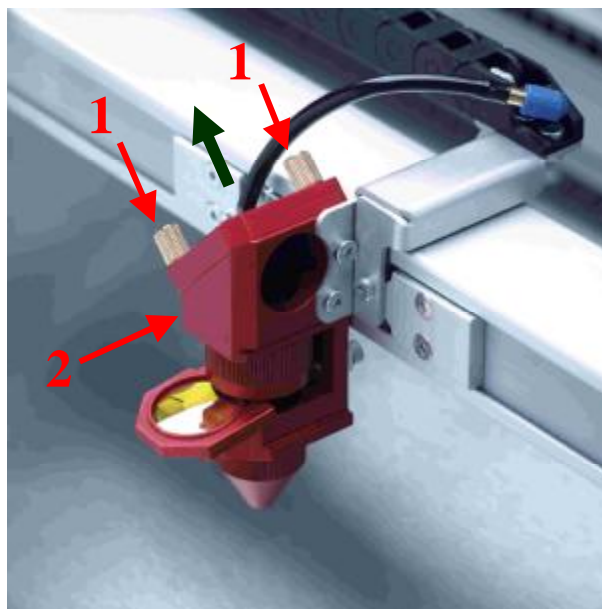

Figure 34

# Operation Manual Trotec Speedy 300

## 5.2 Cleaning the Optical Parts

2. Use a drop of lens cleaning liquid from the accessories box and, while holding the mirror on an angle, flush the surface of the mirror, to wash away coarse soiling.
3. Put the mirror on a working surface. Put some drops of lens cleaning liquid on the mirror and leave the liquid to take effect for approximately 1 minute.
4. Use a folded piece of lens cleaning tissue soaked with lens cleaning liquid and wipe gently over the mirror only once. Use a fresh lens cleaning tissue soaked with lens cleaning liquid each time and again wipe over the mirror only once. Then wipe the mirror dry with a new dry lens cleaning tissue. Never use a cleaning tissue twice, as it could carry dust particles, that can scratch the mirror surface.
5. Examine the mirror and repeat the cleaning process, if necessary.
6. Re-insert the mirror into the mirror holder by setting it straight onto the holder and tightening the screw.

# Operation Manual Trotec Speedy 300

## 5.3 Maintenance Plan

	daily	weekly	monthly	yearly
<b>Laser</b> <input type="checkbox"/>				
Lens, mirror 3	Check Cleaning if required			
Mirror 2		Check Cleaning if required		
Engraving table and rulers	Cleaning			
Cover of the laser tube and housing			Cleaning	
Entire working area – general cleaning			Cleaning	
<b>Exhaust System</b>				
Bag filter	According to the operation manual of the exhaust system			
Filter mat				
Particle filter				
Activated carbon filter				
<b>Cooling System</b> (60 W and 100 W devices only)				
Pump filter			Cleaning	
Condenser heater			Cleaning	
Cooling agent		Examination		Replacement
Pump				Lubricate

For detailed information on the maintenance activities on exhaust and cooling systems please refer to the respective manuals.

## SECTION 6 – ADDITIONAL INFORMATION

- 6.1 Tips for Troubleshooting
- 6.2 Requirements for the Serial Cable
- 6.3 Connector Assignment
- 6.4 Training Program
- 6.5 Support Sheet

# Operation Manual Trotec Speedy 300

## 6.1 Tips for Troubleshooting

- | Speedy does not react after activating the "ON" key.
  - Check the mains connection.
  - Check the main fuses of the Speedy 300. They are located next to the mains connection socket. Replace defect fuses with fuses of the same type and value.
  
- | No referencing is performed after switching on the Speedy.  
An acoustic signal can be heard.
  - Check whether the door of the Speedy is tightly fastened.
  
- | The following error message is displayed when trying to establish a connection between the Manager and Speedy:  
"Could not build up connection to the laser engraver."
  - Check the cable connection between computer and Speedy.
  - Make sure that you are actually using the correct serial interface COM 1 or COM 2 of your computer and that it is functional.
  - Check the interface selection in "Options" in the "Settings" menu of the Manager.
  
- | After starting a job the exhaust system is not switched on.
  - Check whether the exhaust system is connected with the mains socket and whether the mains switch is set to "On"
  - Check the cable connection between Speedy 300 and the exhaust system.
  
- | A job, which was created with the graphics software, does not appear in the waiting list of the Manager.
  - Check whether the sorting function "Kind" and "Resolution" are activated in the waiting list.
  - Make sure that the directories "Archiv", "Spool" and "Work" have been created in the directory of the Manager ("TROTEC") and that the correct paths to these directories have been set under "Options" in the "Settings" menu.
  
- | A job transferred to the Manager does not contain any graphics,
  - Use the "Fit to page" option in the printer menu of your graphics software.

# Operation Manual Trotec Speedy 300

## 6.2 Requirements for the Serial Cable

The following drawing describes the pin assignment for the serial cable:

for PCs (link cable)

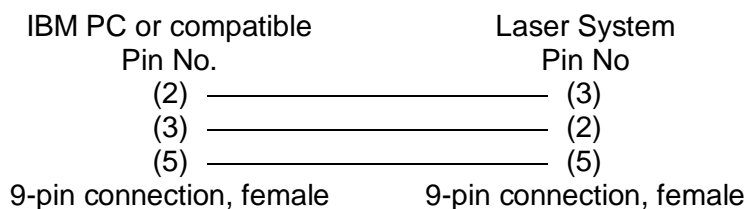

# Operation Manual Trotec Speedy 300

## 6.3 Wiring diagrams – 10W...30W

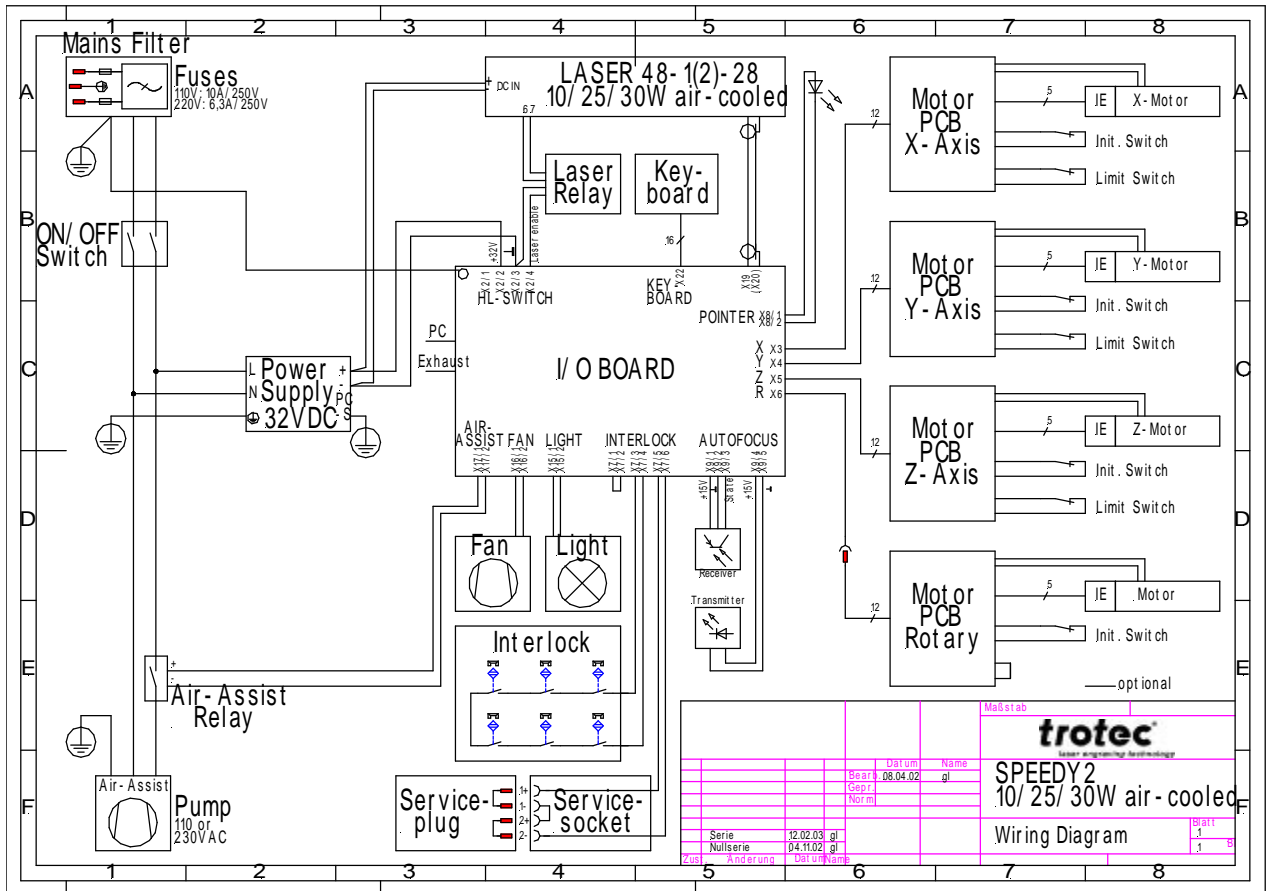





# Operation Manual Trotec Speedy 300

## 6.3 Wiring diagrams – 60W water cooled 110V

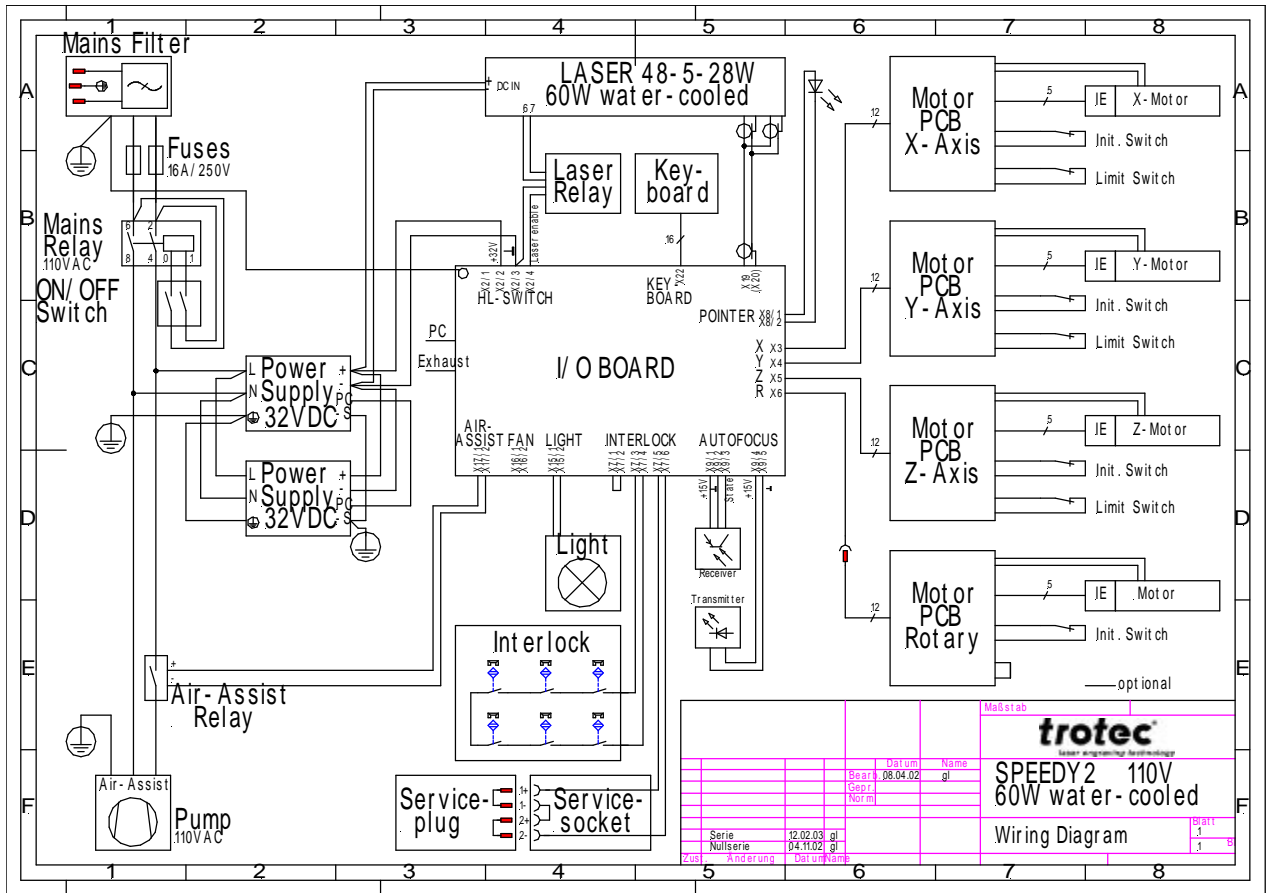

# Operation Manual Trotec Speedy 300

## 6.3 Wiring diagrams – 60W water cooled 230V

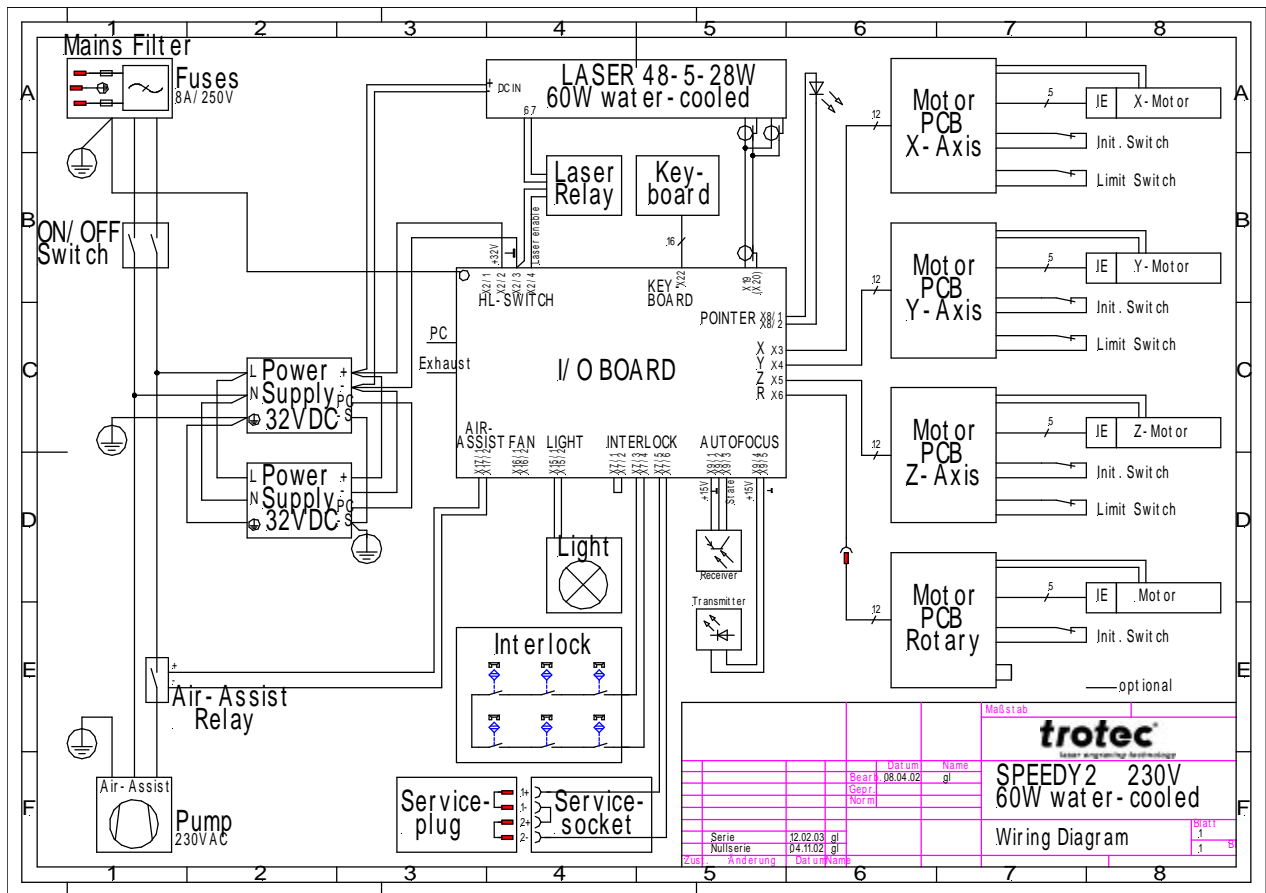

# Operation Manual Trotec Speedy 300

## 6.3 Wiring diagrams – 100W

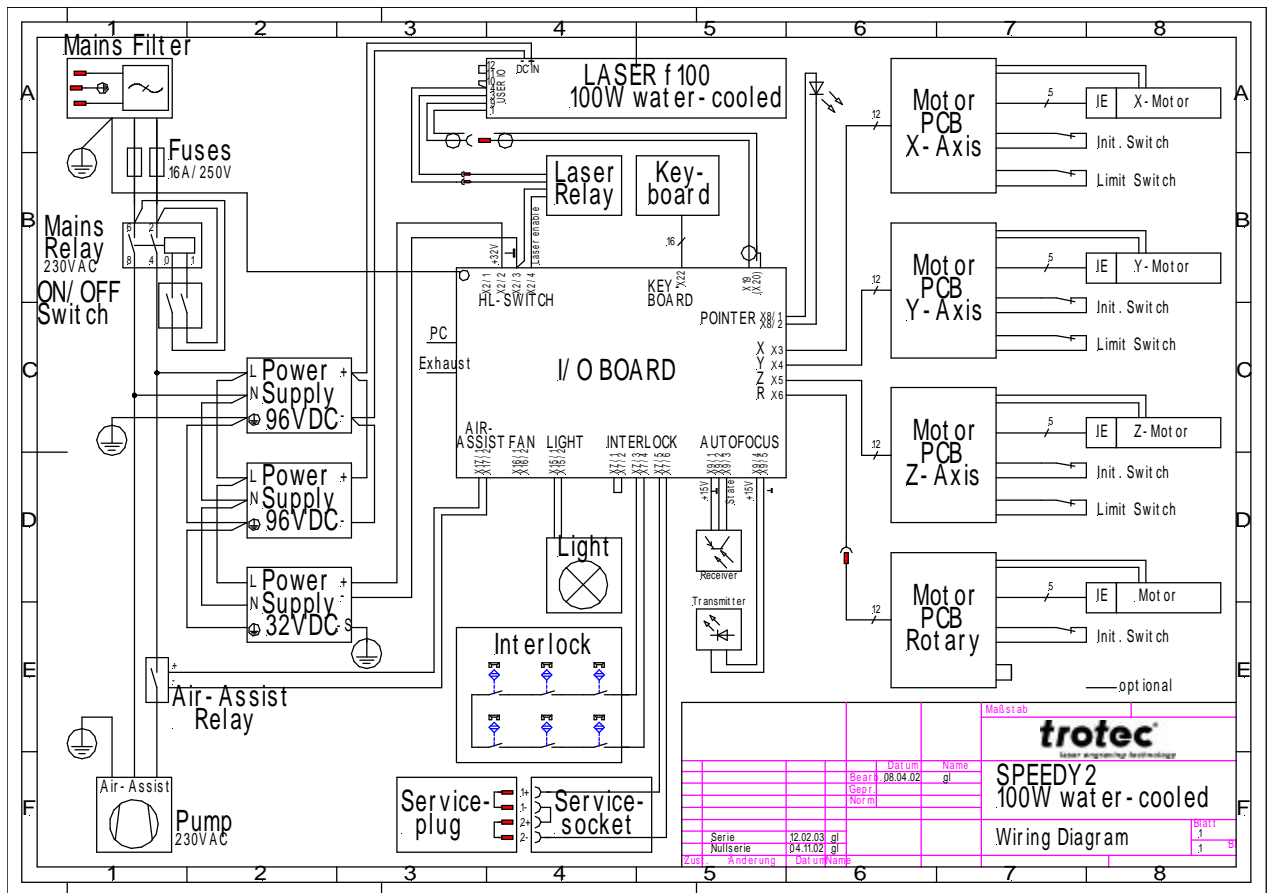

# Operation Manual Trotec Speedy 300

## 6.3 Wiring diagrams – IO board

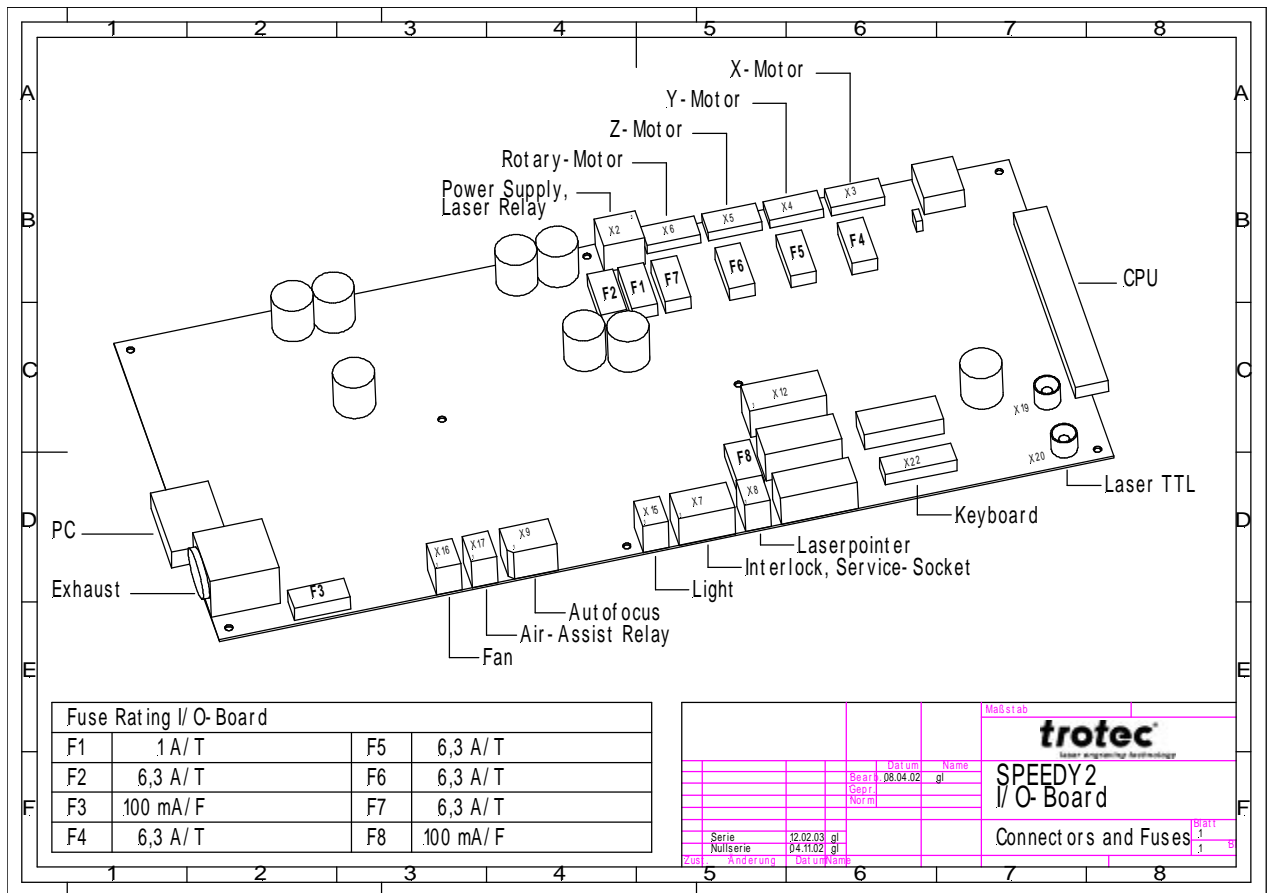

# Operation Manual Trotec Speedy 300

## 6.4 Support Sheet

### Customer Data

Date		Customer no.	
Company		Contact person	
Adress		Phone Fax e-mail	

Problem	.. Engraver	.. Manager	.. Printer Driver
Engraver model		Serial #	

<b>Failure description (how can the problem be reprocessed)?</b>

<b>Error Message</b>

<b>Workpiece</b>		<b>Mode</b>		<b>Material</b>	
------------------	--	-------------	--	-----------------	--

<b>Operating System</b>	
-------------------------	--

Graphicscard		Network	
Main Memory		Hard Disk	
DTP Program		Version	

## Operation Manual Trotec Speedy 300

Remarks

## Processing

Received by		Date	
Forwarded to		On	
Solved by		Close Date	

# Operation Manual Trotec Speedy 300

## APPENDIX

## Operation Manual Trotec Speedy 300

### Options

**Cutting table:** Honeycomb table especially for cutting tasks, is placed onto the standard table, during cutting the residuals of the material fall through the honeycombs onto the table, reverse side of the material remains clean, cutting lines are cleaner.

**2" lens:** This lens is a good compromise between engraving and cutting. To install this lens remove the 1.5" lens and move the fixing ring all the way down, turn it round (so that the thread is on the lower side). Then insert the lens like shown in the picture and tighten the fixing ring.

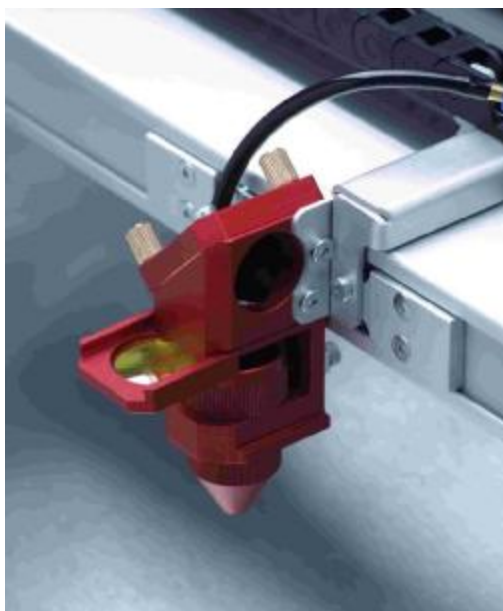

In the Trotec manager the lens must be selected under Settings>Options>Engraver to make the autofocus work correctly.

## Operation Manual Trotec Speedy 300

### 2.5" lens:

This lens is the best choice for cutting thicker materials. It is not used for rubber stamp making, as the energy density is strongly reduced. Loading this lens makes it necessary to remove the nose cone on the bottom of the engraving head.

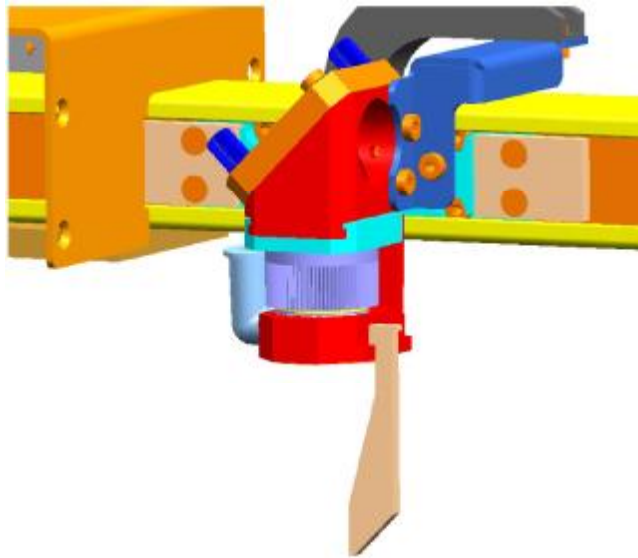

To be able to work with this lens a longer focus tool is needed. Also in the Trotec manager the lens must be selected under Settings>Options>Engraver to make the autofocus work.



Never use the nose cone while working with the 1.5" lens

# Operation Manual Trotec Speedy 300

## TRAINING SCHEDULE

Customer no.		Company, City	
Machine/Type			
Serial No.			
Operating System/ Version			
DTP Program / Version			

CHAPTER 1 <input type="checkbox"/>	<p><b>SAFETY</b></p> <ul style="list-style-type: none"> <li>• Laser safety</li> <li>• Safety, information and warning labels</li> <li>• Interlock system</li> </ul>
CHAPTER 2 <input type="checkbox"/>	<p><b>INSTALLATION</b></p> <ul style="list-style-type: none"> <li>• Installation of the system</li> <li>• Installation of the exhaust system</li> <li>• Installation of the printer driver and the Manager</li> </ul>
CHAPTER 3 <input type="checkbox"/>	<p><b>SOFTWARE (incl. Corel Draw® version 9 or higher)</b></p> <ul style="list-style-type: none"> <li>• Fonts, fillings, outlines, ....</li> <li>• Introduction printer driver and Manager Positioning, selecting material, defining the engraving parameters speed and power raster engraving, cutting, bitmaps, job list, Archive/Spool/Work sub-directories</li> </ul>
CHAPTER 4	<p><b>ENGRAVING TRIALS</b></p> <ul style="list-style-type: none"> <li>• Handling the engraver</li> <li>• Setting the focus position</li> <li>• Parameters for different materials</li> <li>• Handling the rotary engraving attachment (optional)</li> </ul>

# Operation Manual Trotec Speedy 300

## TRAINING SCHEDULE

CHAPTER 5 <input type="checkbox"/>	<b>CLEANING AND MAINTENANCE</b> <ul style="list-style-type: none"> <li>• General cleaning of the system</li> <li>• Cleaning the optics</li> <li>• Cleaning the exhaust system and replacing the filters</li> <li>• Observance of the maintenance intervals</li> </ul>
CHAPTER 7 <input type="checkbox"/>	<b>ELECTRONICS</b> Explanation of the electronics (prints) Explanation of the fuses <input type="checkbox"/> <input type="checkbox"/>
CHAPTER 8 <input type="checkbox"/>	<b>LASER SOURCE</b> <ul style="list-style-type: none"> <li>• Description and attachment</li> </ul>
CHAPTER 9 <input type="checkbox"/>	<b>BEAM ALIGNMENT</b> Adjusting the deflection mirror 2 <input type="checkbox"/> <input type="checkbox"/>
KAPITEL 10 <input type="checkbox"/>	<b>ADJUSTING ENGRAVING TABLE AND RULERS</b> Explanation of the adjustment of the rulers and the engraving table. <input type="checkbox"/>

- Training performed in .....
- Training, test and installation at customer, location

Remarks:	
----------	--

CUSTOMER

TECHNICAL SUPPORT

DATE / SIGNATURE

DATE / SIGNATURE

# Operation Manual Trotec Speedy 300