

OPERATION MANUAL

**8005 Trotec Professional
C50 / C100 / C200 / C300**

PART A - Hardware

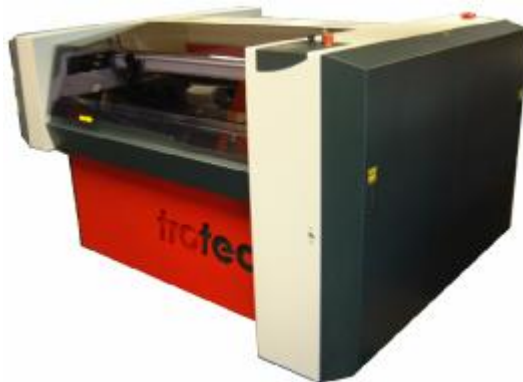

1. Issue 10/2001

© This documentation with all illustrations is intellectual property of
Trotec Produktions- u. Vertriebs GmbH.

The entire documentation is given to the user for personal use only.
This documentation must not be reproduced or made available to others without our written
permission. Any breach of law will be prosecuted.

TP1313

Trotec GmbH

Linzer Strasse 156
A – 4600 Wels

Ph.: ++43/7242/239-0
Fax: ++43/7242/239/7380
E-Mail: trotec@trodat.net

Operation Manual Trotec Professional



TROTEC PRODUKTIONS UND VERTRIEBS GmbH

Freilingerstraße 100
A – 4614 Marchtrenk
AUSTRIA

Ph.: +43 / 7242 / 239-0

Fax: +43 / 7242 / 239-7380

E-Mail: trotec@at.trodat.net

Support: support@at.trotec.net

www.trotec.net



TROTEC cannot be held responsible for any direct or indirect damages, which result from using or working with the products electric circuits or software described herein. The apparatus must be used only by trained and skilled personnel. Before use the manual should be read and followed carefully.

Furthermore TROTEC reserves the right to change or alter any product described herein without prior notice.



In case of failure, please check the device first according to section 6.1 (page 62) - Troubleshooting. If unsuccessful, please note all data of the device (year of manufacture, software version, etc.) and call us from a telephone next to the switched on device.

For queries or technical problems please contact your dealer or TROTEC directly at the above address.

Trotec GmbH

Linzer Strasse 156
A – 4600 Wels

Ph.: ++43/7242/239-0
Fax: ++43/7242/239/7380
E-Mail: trotec@trodat.net

Operation Manual Trotec Professional

TABLE OF CONTENTS

Table of Contents	1
-------------------	---

SECTION 1 – GENERAL

1.1	General Information on the Use of the Operation Manual	4
1.2	Designated Use	5
1.3	Technical Data / Device Specification	6
1.4	Manufacturer's Label	7
1.5	EU Declaration of conformity	8
1.6	Warranty Regulations	9

SECTION 2 – SAFETY

2.1	General Safety Information	11
2.2	Laser Safety Information	13
2.3	Safety Precautions When Operating the Device	14
2.4	Warning and Information Labels	16

SECTION 3 – BEFORE OPERATION

3.1	Unpacking the Professional	20
3.2	Contents of Delivery	23
3.3	Location	24
3.4	Exhaust System – Requirements	25
3.5	Cooling System – Requirements	25
3.6	Computer – Requirements	25
3.7	Connecting the Professional	26
	3.7.1 Connecting the Mains	26
	3.7.2 Connecting the Computer	27
	3.7.3 Connecting the Exhaust System	28
	3.7.4 Connecting the Cooling System	30

Operation Manual Trotec Professional

Table of Contents

SECTION 4 – OPERATION

4.1	System View / Assemblies and Control Elements	34
4.2	Control Panel	37
4.3	First Steps Before Engraving	41
4.4	First Engraving Tests	44
4.5	Tips and Tricks for Laser engraving	47
4.6	Tips and Tricks for Laser Cutting	49
4.7	Tips and Tricks for the Producing Rubber Dies	50

SECTION 5 – MAINTENANCE

5.1	Cleaning the System	52
5.2	Cleaning the Optical Parts	53
5.3	Maintenance Plan	60

SECTION 6 – ADDITIONAL INFORMATION

6.1	Tips for Troubleshooting	62
6.2	Requirements for the Serial Cable	63
6.3	Connector Assignment / Wiring diagram	64
6.4	Support Sheet	71

SECTION 7 – INDEX

7.1	Index	73
-----	-------	----

APPENDIX

Options	76
---------	----

Operation Manual Trotec Professional

SECTION 1 – GENERAL

- 1.1 General Information on the Use of the Operation Manual
- 1.2 Designated Use
- 1.3 Technical Data / Device Specification
- 1.4 Manufacturer's Label
- 1.5 EU Conformity Declaration
- 1.6 Warranty Regulations

Operation Manual Trotec Professional

1.1 Operation Manual Use. – General Information

Caution:

Please read and follow this Operation Manual carefully, before installation and operation. Damage to persons and/or material can result from not following individual points of the Operation Manual !

Operation of the system is only permitted with equipment and spare parts supplied or listed in the spare parts and consumables lists.

Auxiliary equipment must be adjusted to the base machine (any queries to dealer or manufacturer).

The following symbols are used for easier understanding of the Operation Manual:



If the Operation Manual is not observed, this area represents a particular danger for the operating personnel or the personnel responsible for maintenance.



Caution: This component is under voltage. In these areas strictly observe the safety instructions regarding electricity, care is to be taken in particular during maintenance and repair work.



Caution: In this area pay attention to the possible dangers of the laser beam.



Note or information on individual components of the device, that simplify the use or make it more understandable.

(30/11)

Reference to several parts, which are described in more detail on a different page of the Operation Manual. The first number indicates the page, the second number indicates the part number on this page.

Operation Manual Trotec Professional

1.2 Designated Use

The TROTEC laser engraving and cutting system Professional is used for engraving and cutting of signs, stamps and suchlike.

A wide variety of materials such as rubber, acrylic, coated metal, tin, special steel, elox-aluminum, cork, cardboard, glass, leather, marble, several plastics, and wood can be processed on the laser engraver.



The engraving process must only be performed with a perfectly adjusted machine (see also Section 4 – Operation).



Use of the system in other areas is against the designated use. The manufacturer does not admit liability for damage to personal and/or equipment resulting from such use.



The system must only be operated, maintained and repaired, by personnel that are familiar with the designated field of use and the dangers of the machine !



Non-observance of the instructions for operation, maintenance and repair described in this Operation Manual excludes any liability of the manufacturer if a defect occurs.

Operation Manual Trotec Professional

1.3 Technical Data / Device Specification

Model designation	8005 Professional
max. engraving surface	1300 x 1300 mm
max. workpiece size	1500 x 1500 x 135 mm
max. engraving speed	100 cm/sec.
Laser type	50 W sealed-off CO ₂ laser water-cooled
	100 W sealed-off CO ₂ laser water-cooled
	200 W sealed-off CO ₂ laser water-cooled
	300 W sealed-off CO ₂ laser water-cooled
Wavelength of the laser radiation	10.6 µm
Focal length	2.5 inch (standard lens), 5 inch as option
Repetition accuracy of positioning	+/- 0.025 mm
Interfaces	1 x O Modem Cable = RS-232C PC
Dimensions	2400 x 2000 x 1300 mm
Weight	depending on laser about 1200kg
Laser safety class	Class 2
Height adjustment of working surface	200 mm
Power consumption	Professional C50: 1300 W / 16A Professional C100: 2600 W / 25A Professional C200: 5200 W / 3x25A Professional C300: 7800 W / 3x25A
Sound pressure level	70 dB(A)

Prerequisite for the installation:



Mains: fuse 25A characteristics B or C
 <100W: AC voltage; 220 - 240 V; 50 Hz
 other: AC voltage; 3x220 - 240 V; 50...60 Hz

Room temperature 20 ° to 25 °C

Air humidity <70%

Operation Manual Trotec Professional

1.4 Manufacturer's Label

The manufacturer's label is located in the center of the back of the device (see Figure below).



Figure 1

It is recommended to enter data such as serial number and year of manufacture into the manufacturer's label below so that you always have this data handy if you have problems with your device or require spare parts.

TROTEC LASER ENGRAVER		
Modell	Typ:	Speedy
Seriennummer:	Serial No:	
Baujahr:	Manufactured:	
Stromaufnahme	Input Power:	220-240VAC~, 3.6A, 50Hz
Schaltplan:	Wiring diagram:	BlocksbSP.dwg
Hersteller:	Manufacturer:	TROTEC Produktions u. Vertriebs Ges.m.b.H Linzerstraße 156, Wels AUSTRIA
CO2-Laser, max. Leistung 75W _{av} , Wellenlänge 10,6µm nach EN 60825-1 (1997)		
		

Figure 1a: example of the ID label

Operation Manual Trotec Professional

1.5 EU – Declaration of conformity

The manufacturer

TROTEC Produktions- u. Vertriebs GmbH.

Linzer Strasse 156,
A-4600 Wels, OÖ.,
AUSTRIA

hereby declares that the following product

TROTEC 8005 PROFESSIONAL
Model N° 8005 Professional C50/100/120/200/240/300

has demonstrated conformity to the following guidelines:

98/37/EC Directive for Machines
73/23/EEC Low Voltage Directive
89/336/EEC EMC Guideline and
92/31/EEC Amendment

Applied during design and construction of this product:

- EN 60204-1 Machine Safety
- EN 60825-1/1997 Safety of Laser Equipment
- EN 50081/2 and EN 50082/2 Electromagnetic Compatibility

Wels, 1st January, 1999

Trotec Produktions u. Vertriebs Ges.m.b.H



1.6 Warranty Regulations

1. Issue Issue 12/99 Technical changes reserved	© Trotec Produktions- u. Vertriebs GmbH Linzer Strasse 156 A – 4600 Wels	Page 8
---	--	---------------

Operation Manual Trotec Professional

For devices of the laser product family Trotec Professional TROTEC Produktions- und VertriebsGmbH, Wels (hereinafter called "TROTEC") grants a warranty of one year from the date of purchase (datum of distribution). During this time TROTEC will, according to your preference, replace all parts of those products, which by failure in material or design cause a failure of the readiness for operation, with a part of equal value or to repair it free of charge. Under warranty the cost of both parts and freight (standard freight) are covered by TROTEC.

TROTEC must be notified immediately if faults are noticed. Send the part in its original packaging to TROTEC or to a designated point of service and at TROTEC's discretion, customers receive a credit note for sending the replacement part. All replaced parts become property of TROTEC. Repair of failures does not extend the warranty obligation.

Wear-and-tear on parts is not covered by the warranty with the following exceptions; A warranty covers 1000 hours operating time for wear-and-tear on parts of motors (in particular replacement of brushes of the servo motors.). Optics (lenses and mirrors) are covered by a three-year warranty when an exhaust system from TROTEC is used, or if a different exhaust system is used and a certification of the flow capacity is presented immediately and certified by TROTEC in writing to be sufficient. The warranty for optics however is void if replacement is necessary due to insufficient or inappropriate cleaning (e.g. scratching during cleaning). (Typical image with optics damaged by inappropriate cleaning: Shooting through mirror or lens). The refilling of the laser tube with gas mixture is considered natural wear-and-tear and is not covered by the warranty. With wear-and-tear on parts, the warranty only covers damage that already existed at the time of distribution of the device, and was claimed immediately.

No warranty covers damage resulting from the following: Inappropriate handling, inadequate or inappropriate maintenance and cleaning, external influences (e.g. voltage fluctuations), operation and installation errors, transport damage, modifications, added parts and interference not performed by TROTEC authorized persons, use of unsuitable accessories or operating material.

Any improper use or modification of the devices without previous permission by TROTEC renders the warranty void. TROTEC is under no circumstances liable for the loss of profit, turnover, company value or expected cost-savings or special, direct or indirect damages resulting from the use or attempted use of the product, even if TROTEC has been advised of the possibility of such damages. TROTEC is also not liable for claims, being made by third parties against the customer. Therefore, in particular costs for third parties assigned without the explicit agreement of TROTEC and costs for replacement devices, cleaning and maintenance work will not be born.

TROTEC reserves the right to implement technical innovations as well as later changes to the warranty regulations. Place of performance and venue for both parties is Wels, the laws of the Republic of Austria apply exclusively.

Operation Manual Trotec Professional

SECTION 2 – SAFETY

- 2.1 General Safety Information
- 2.2 Laser Safety Information
- 2.3 Safety Precautions when Operating the Device
- 2.4 Warning and Information Labels

Operation Manual Trotec Professional

2.1 General Safety Information

All personnel involved in installation, set-up, operation maintenance and repair of the machine, must have read and understood the Operation Manual and in particular the "Safety" section. The user is recommended to generate company-internal instructions considering the professional qualifications of the personnel employed in each case, and the receipt of the instruction/Operation Manual or the participation at introduction/training should be acknowledged in writing in each case.

Safety-conscious Working

The machine must only be operated by trained and authorized personnel.

The scopes of competence for the different activities in the scope of operating the machine must be clearly defined and observed, so that under the aspect of safety no unclear questions of competence occur. This applies in particular to activities on the electric equipment, which must only be performed by special experts.

For all activities concerning installation, set-up, start-up, operation, modifications of conditions and methods of operation, maintenance, inspection and repair, the switch-off procedures that may be provided in the Operation Manual must be observed.

Safety Information for the User and/or Operating Personnel

- No work methods are permitted that affect the safety of the machine.
- The operator must also ensure that no unauthorized persons work with the machine (e.g. by activating equipment without authorization).
- It is the duty of the operator, to check the machine before start of work for externally visible damage and defects, and to immediately report changes that appear (including behavior during operation) that affect the safety.
- The user must provide that the machine is only operated in perfect condition.
- The user must guarantee the cleanness and accessibility at and around the machine by corresponding instructions and controls.

Operation Manual Trotec Professional

2.1 General Safety Information

- Principally, no safety components may be removed or disabled (already here we emphasize the imminent dangers, for example severe burns, loss of eye-sight). If the removal of safety components is required during preparation, repair and maintenance, the replacement of the safety components must be performed immediately after completion of the maintenance and repair activities.
- Preparation, retooling, change of workpiece, maintenance and repair activities must only be performed with equipment disconnected from supply network, by trained personnel.
- It is forbidden to perform unauthorized modifications and changes to the machine. It is emphasized, that any unauthorized modifications to the machine are not permitted for safety reasons.



Operation Manual Trotec Professional

2.2 Laser Safety Information



To assess the potential dangers laser systems pose, they are classified into 5 safety classes: 1, 2, 3a, 3b and 4. The Professional is a device of **class 2** and consequently absolutely safe. This is guaranteed by the protective housing and the safety installations.

Please note that improper operation of the device can override the status of safety class 2 and can cause the emission of harmful radiation.



This laser engraving system contains a carbon dioxide (CO₂) laser of class 4, that emits **intensive** and **invisible** laser radiation. Without safety precautions the direct radiation or even diffuse reflected radiation is dangerous!



Without safety precautions, the following risks exist with exposure to laser radiation:

Eyes: Burns to the cornea
Skin: Burns
Clothing: Danger of fire



Never try to modify or disassemble the laser and do not try to start up a system that had been modified or disassembled!



Dangerous radiation exposure can result from the use of operation or adjustment equipment other than that described here, and if different operational methods are performed.



Service technicians using the service plug are required to wear standard laser safety glasses for CO₂ lasers (wavelength 10.6 µm).

Operation Manual Trotec Professional

2.3 Safety Precautions when Operating the Device

In your Professional, a closed safety system is integrated which immediately switches off the power to the laser tube when the protection cover is opened. Consequently an incomplete engraving can occur if the cover is opened during operation. Therefore, first press the "PAUSE" button, if you want to interrupt an engraving process.

Please remember the following safety precautions when working with this device:

A fire extinguisher must always be handy as the laser beam can ignite flammable materials. Do not store any flammable materials in the inside of the device or in the immediate vicinity of the device.

Unsupervised operation of the system is not permitted.

Because of their low absorption many metals, in particular un-coated aluminum, copper, silver and gold cannot be processed with the laser engraver and lead to high reflections of the laser beam. Such materials must not be inserted into the beam path in an uncontrolled way, as a directed reflection could destroy the protection cover.

Adjustment of the beam path must be performed only by especially trained personnel. An improper setting can lead to uncontrolled emission of the laser radiation.

Before processing materials the user must verify, whether harmful materials can be generated and whether the filter equipment of the exhaust system is suitable for the harmful materials. We emphasize that it is the responsibility of the user, to consider the national and regional threshold values for dust, fogs and gases when selecting the filters and the exhaust system. (The values for the maximum workplace concentration must not be exceeded.)

Please refer to the manual of the exhaust system on how and in what intervals you need to replace filters.

PVC (polyvinyl chloride) must under no circumstances be processed with the laser engraver.

Should you have further questions before starting work, please contact your dealer or TROTEC.

Operation Manual Trotec Professional

2.4 Warning and Information Labels



The warning and information labels are attached in such positions of the device that could represent a source of danger during set-up and operation. Therefore, follow the information on the labels. If labels are lost or damaged, they must be replaced immediately.

Operation Manual Trotec Professional

2.4 Warning and Information Labels

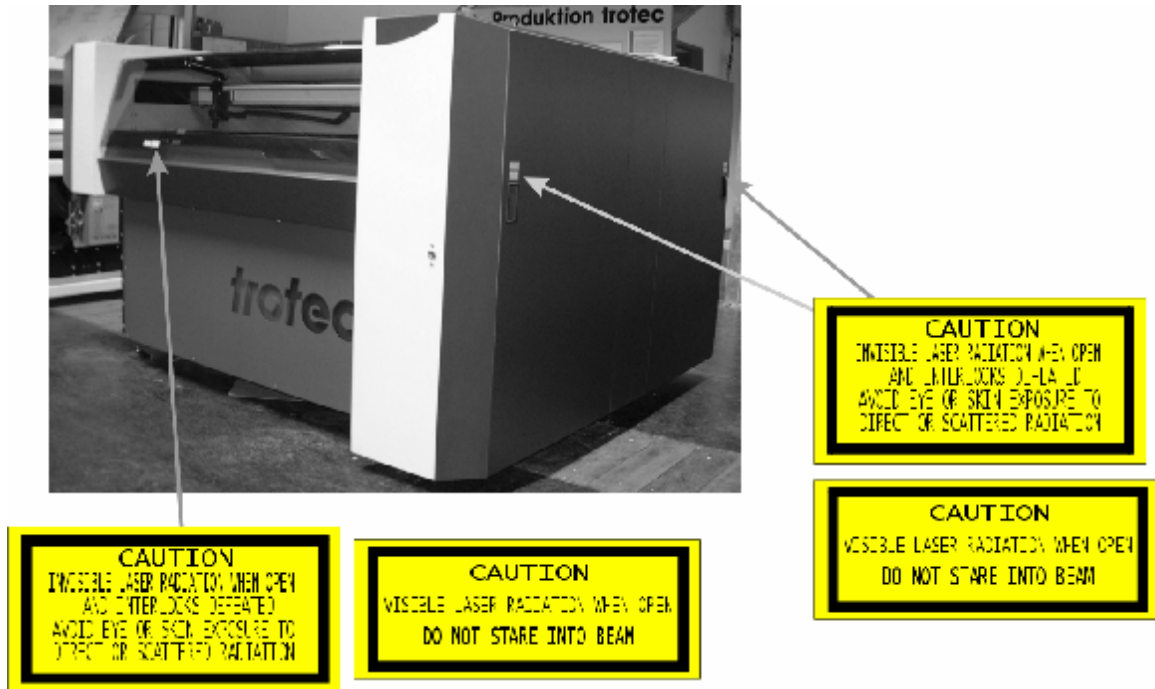

Figure 3

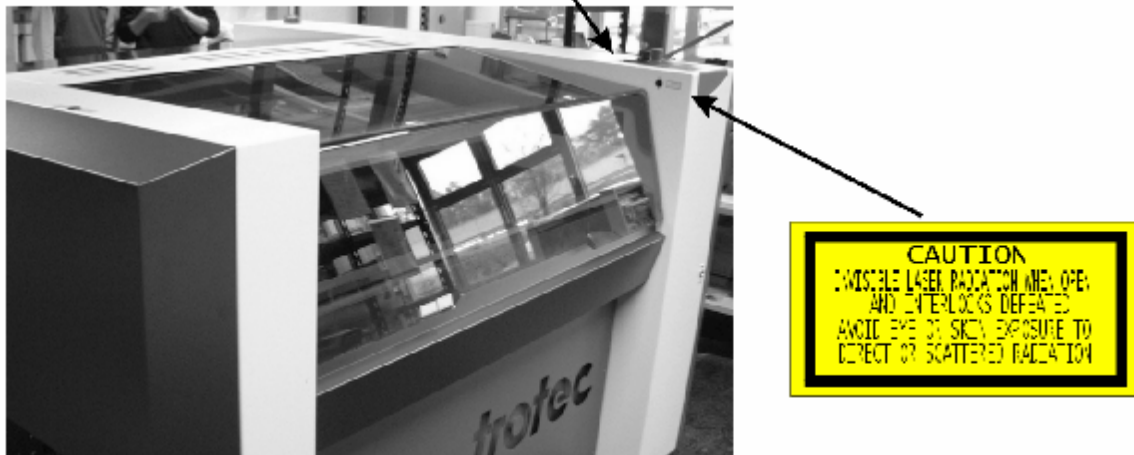

Figure 4

Operation Manual Trotec Professional

2.5 Warning and Information Labels

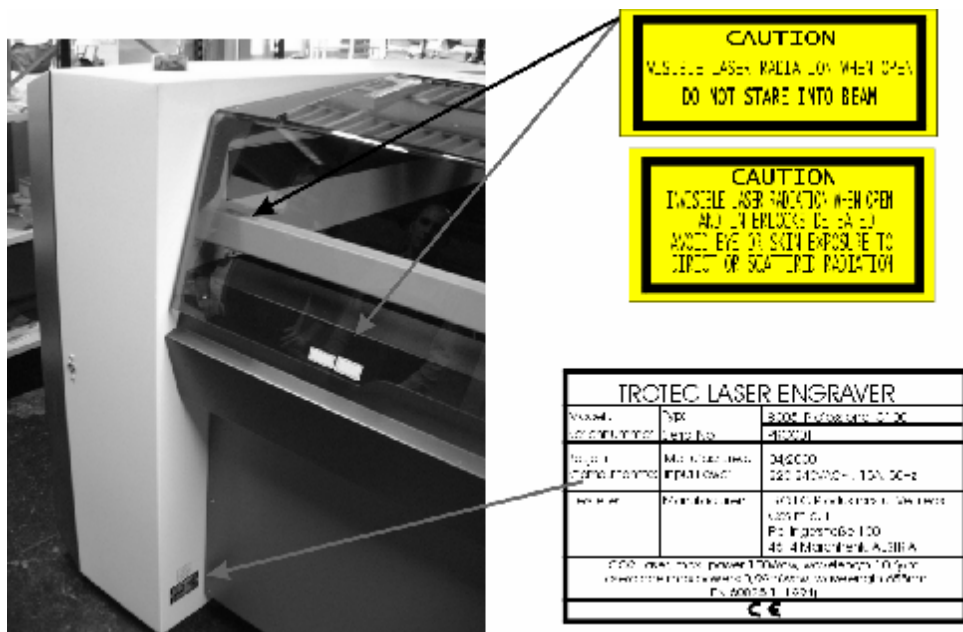

Figure 5



Figure 6



Operation Manual Trotec Professional

2.5 Warning and Information Labels

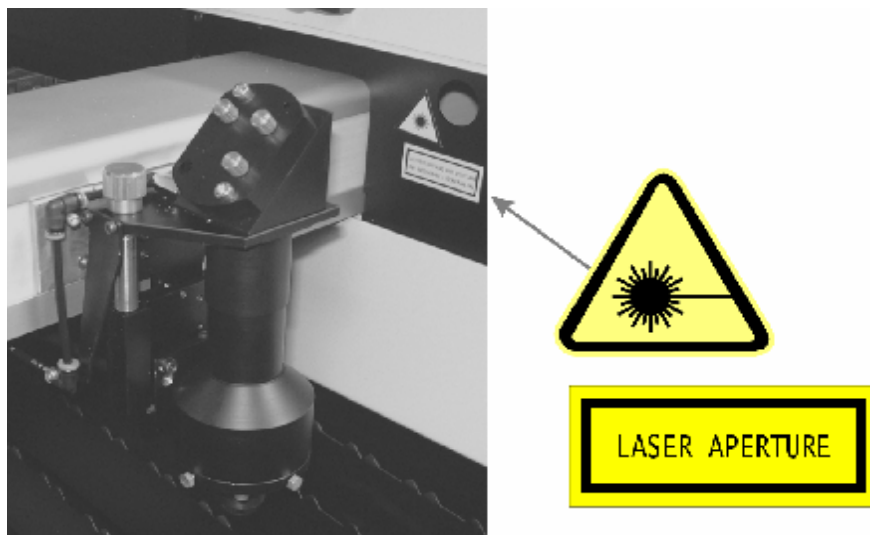
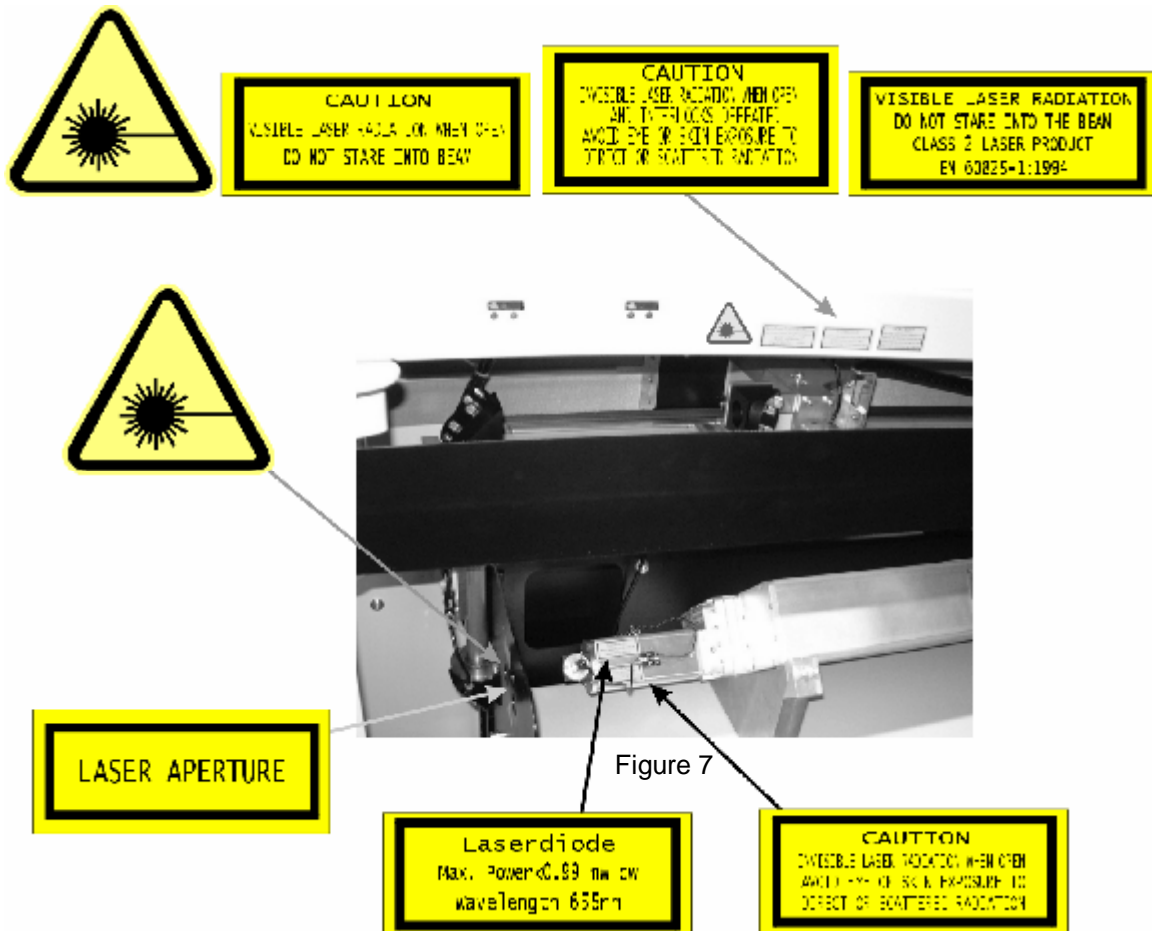

Figure 8

Operation Manual Trotec Professional

SECTION 3 – BEFORE OPERATION

- 3.7 Unpacking the Professional
- 3.7 Contents of Delivery
- 3.7 Location
- 3.7 Exhaust System – Requirements/Connection
- 3.7 Cooling System – Requirements/Connection
- 3.7 Computer Requirements
- 3.7 Connection of the Professional

Operation Manual Trotec Professional

3.1 Unpacking the Professional

You receive your Professional packed in a wooden box, that contains the laser and additional accessories. The following steps give you an overview of the unpacking and assembly of the laser. Please follow these steps carefully.



If possible keep the packing box. You might require it in case of a return.

1. Remove the top cover of the wooden box. Then the side covers. For this work we strongly recommend to use an electric screwdriver.



Figure 9: the Professional kept in position by wooden spacers

Please note that the machine housing is reinforced only on certain positions so that a fork lift truck can lift the machine.

These positions are:

- machine front (figure 9)
- machine back
- left side of the machine

Never place the forks on other positions, as this could cause severe damages on the housing and affect cutting precision as well as life expectancy of the motion system.

Operation Manual Trotec Professional

3.1 Unpacking the Professional

2. Carefully lift the machine from the box floor



Figure 10

3. Position the laser engraver on an even floor capable of carrying the machine weight. This location must meet the ambient requirements mentioned below.



Figure 11

Operation Manual Trotec Professional

3.1 Unpacking the Professional

4. Open the accessories box which you will find on the engraving area.

5. Remove the transport protection which prevents the X-axis arm from shaking during transport. Make sure that it is possible to:
 - move the engraving head from left to the outermost right position
 - move the X-axis arm from the front to the outermost back positionwithout feeling any bigger fluctuations in the mechanical resistance.

Operation Manual Trotec Professional

3.2 Contents of Delivery

- Transport and service packaging
- Laser engraver including all optics
- Water chiller

- Accessories box, which contains the following parts:
 - CD TROTEC Manager software/Engraver driver software/Operators manual (1)
 - Lens cleaning tissues / Optics cleaning liquid (2)
 - Focussing gauge (6)
 - Allen key set 1.5 - 10 mm (7)
 - Computer connection cable (4)

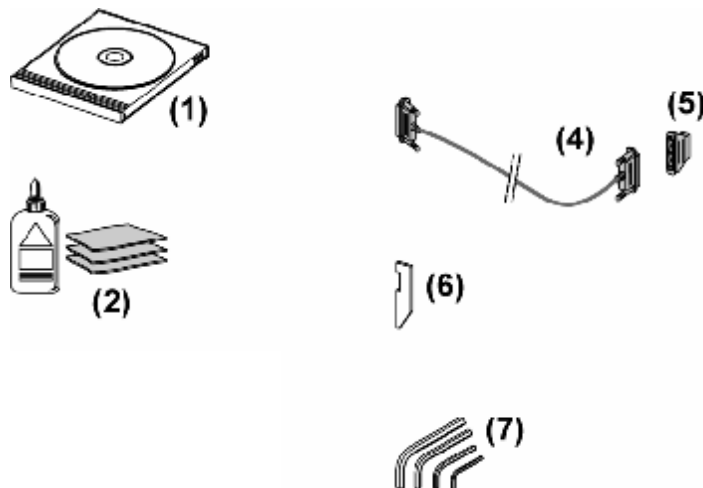

Figure 12: available accessories

Operation Manual Trotec Professional

3.3 Location

Before you install the laser system, you should select an appropriate location. Follow the guidelines shown below:



Avoid locations where the system is exposed to high temperatures, dust and high humidity. (The humidity must not exceed 70% and the temperature must not be close to the dew point.)



Avoid locations, where the system is exposed to mechanical shocks.



Fuse protection of 16 amperes

(for up to 100W single phase – otherwise 3 phase).

Do not connect other devices via this fuse, as the laser engraver system requires the full 16 amperes.



Avoid locations with poor air circulation.



Select a location, whose room temperature is between 20 °C and 25 °C. Avoid higher ambient temperatures and strong exposure of the engraver to the sun. Use blinds, if required.



Select a location close to ventilation (if available).



Select a location that is not more than 2.50 m away from your computer (max. cable length to avoid disturbing interferences).



Try to place a working table or a place to put things next to it. This shall avoid, that the Professional is misused as a table.

Operation Manual Trotec Professional

3.4 Exhaust System – Requirements



To guarantee the right ventilation during the cut process, an exhaust system with a suction power of minimum **750 m³/h** is required. The device must be equipped with a preliminary filter and a fine dust filter (generation of rubber dust) as well as an activated carbon filter (neutralization of smells). A good filtering of the outgoing air is also required when cutting plastics or engraving wood. If only elox plates are engraved, the suction power can be reduced. Connection - see section 3.7.3



Do not start the Professional without an adequate exhaust system.

3.5 Cooling System – Requirements



To achieve sufficient cooling of the laser tube, the Professional requires the installation of a cooling aggregate. Set the water temperature to 25°C (never smaller than 20°C because of condensation). Connection - see section 3.7.4

3.6 Computer – Requirements



The following recommendation represents the **minimum requirements**. When using a more powerful computer the graphics are generated and displayed faster and the computing times and the data transfer to the laser are reduced.

- Pentium 1000 or more powerful PC-compatible computer
- 64 MB RAM
- 1 GB hard disk
- CD ROM drive
- VGA color monitor
- mouse
- 1 free serial interface for the laser engraver
- Microsoft Windows 95®/98/98ME/2000/XP/NT
- Windows-compatible graphics software
- Vision numeric Type3 or TroCAM

Operation Manual Trotec Professional

3.7 Connecting the Professional

All important connectors are on the right side of the machine



Perform the connections exactly in the order described, otherwise electrostatic charging can damage your computer and/or the electronics of the laser system.

3.7.1. Connecting the Mains

Connect the Professional to the supply network via the Main connector X100. This connector is located on the front left corner of the machine below the engraving area.

Please contact the pins as mentioned in the wiring diagram shown in section 6:

- 1: L1 (phase1)
- 2: L2 (phase2)
- 3: L3 (phase 3)
- 4: N
- 5: PE

A certified electro firm has to take care of that and guarantee a sufficient tension relief.



Connector X100



Mains voltage and operating voltage must correspond (AC 230 V/50 Hz single phase or AC 3x230 V/50..60Hz Hz three phase) – see information label indicated below .

Operation Manual Trotec Professional

Under no circumstances switch on the device if the voltages do not correspond.



Figure 14: ID label

The following picture shows behind which panel the main connector is located.

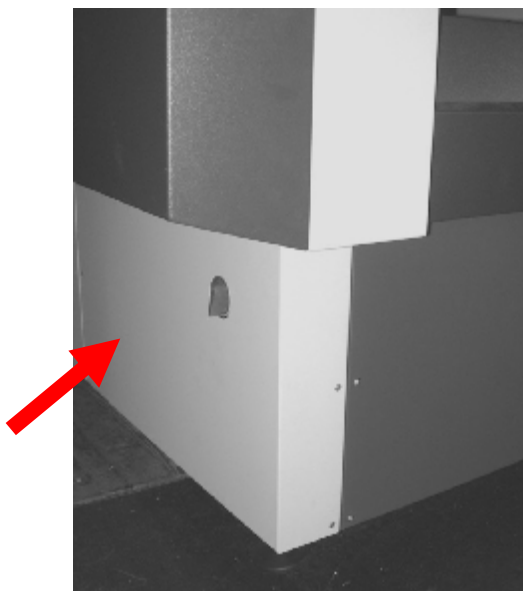

Operation Manual Trotec Professional

Figure: location of main connector

Operation Manual Trotec Professional

3.7 Connecting the Professional

3.7.2 Connecting the Computer



The computer must be connected to the same electric circuit as the Professional and switched off.

Connect the machine (see Figure below) to a free serial interface on your computer. For this use the serial cable from the accessories box.

To feed the cable through the housing use one of the holes in the corners. They provide a connection from the lower side of the machine to the inside of the machine.

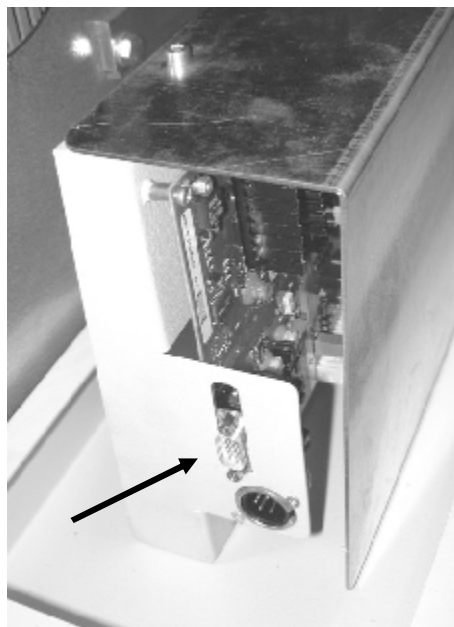

Figure 15: serial connector on the Professional

Operation Manual Trotec Professional

3.7 Connecting the Professional

3.7.3 Connecting the Exhaust System

For putting the exhaust system into operation please follow the instructions in the Operation Manual of the exhaust system.



Make sure that the mains voltage corresponds with the voltage allocated for the exhaust system.

To connect the Professional and the exhaust system use a 160mm diameter hose. One end fits on the connecting piece of the machine, the other end into the exhaust system.

The connectors for the cooling water and the extraction hose are in the back right corner.

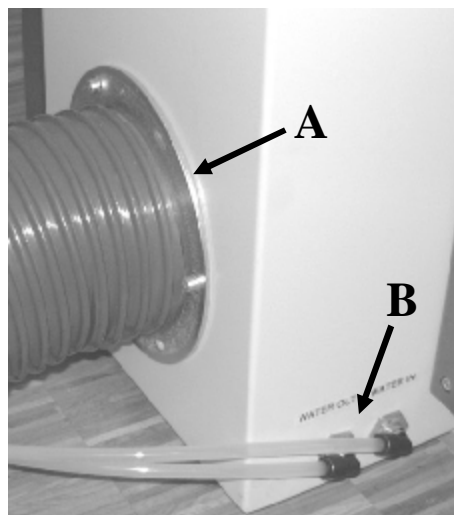

Figure 16: hose connectors

A...exhaust hose connector
B...cooling hose connectors

Operation Manual Trotec Professional

3.7 Connecting the Professional

3.7.4 Connecting the Cooling System

Note: It's important to connect the "water in" of the Professional with the "water out" of the chiller, and the "water out" of the Professional with the "water in" of the chiller.

The machine contains a flow sensor which is direction sensitive. This sensor makes sure, that the tube can not be overheated. If the machine starts up normally but has no laser output, an incorrect flow direction could be the reason. In this case exchange the two hoses to change the flow direction. Set the temperature to 22°C.

These instructions are true for using a Neslab Chiller. For the National Lab chiller, please refer to the instructions in the chiller manual



The installation of the cooling system – for cooling of the laser tube – is required for all Professional Professional machines.

1. Connect the cooling system to the mains voltage.



The mains voltage must correspond with the voltage specified on the cooling system.

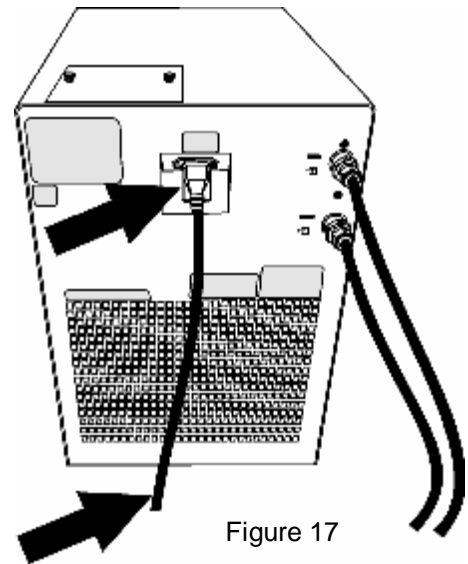

Figure 17

2. Two hose connectors are located on both the left-hand side of the laser tube as well as rear side of the cooling system. Plug the two hoses, which were included in the delivery, into these connectors.

Operation Manual Trotec Professional



The arrangement of the hoses is important. Please connect the black hose with the black adapter and do the same with red.

3. To fill the reservoir, perform the following procedures:

- Undo the two screws (1) at the protection cover and remove the protection cover (2).
- Open the plug of the reservoir (3) and fill the reservoir with **distilled water**. The capacity of is approx. 30 liters.

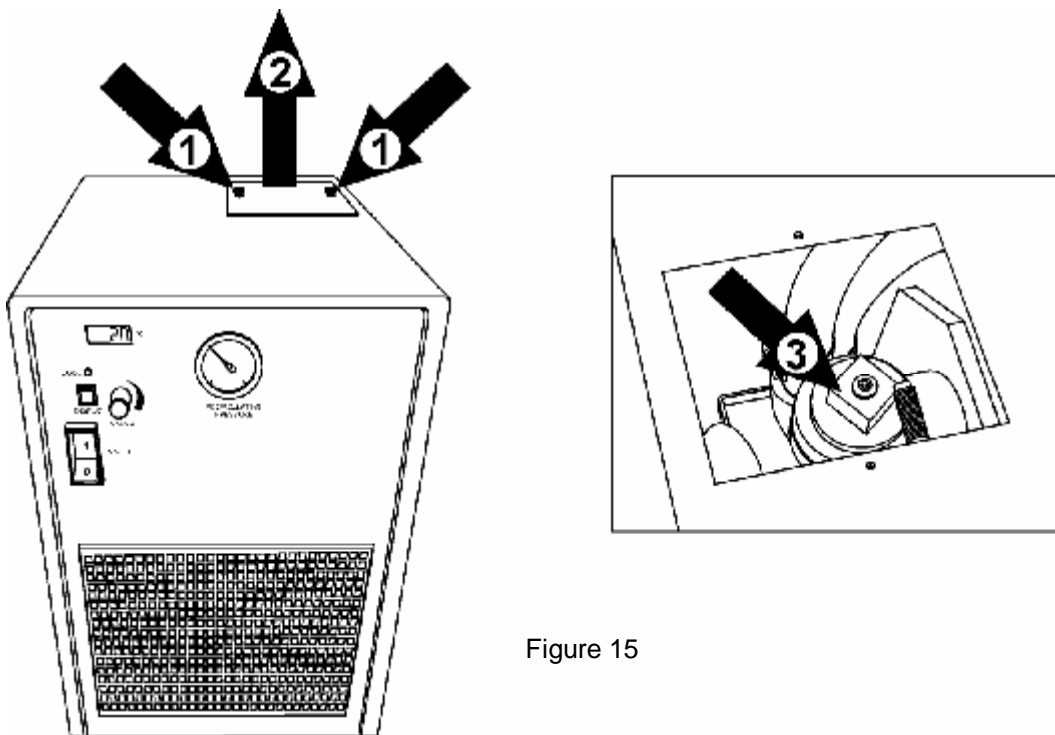

Figure 15

The 30 liters capacity is an approximate value.



Fill the reservoir until the water level is 3 cm below the upper edge of the filler neck. Shake the cooling system from time to time during the process of filling and refilling, this guarantees that, the water fills correctly. The water level must be checked regularly.

Subsequently refit the plug of the reservoir and the protection cover.

Operation Manual Trotec Professional

3.7 Connecting the Professional

3.7.4 Connecting the Cooling System

4. To set the temperature perform the following steps:

- Switch on the cooling system by setting the main switch (1) to "ON" (the switch is illuminated, when the device operates).
- Set the desired temperature. To do this, press the "Display" switch (2), hold the switch in, and simultaneously turn the "Adjust" switch (3) until "20°" appears on the display (4). When the temperature is set, release the "Display" switch.
- The actual temperature of the cooling liquid in the reservoir is shown on the display (4). Do not set the desired temperature to a lower value or condensation on the optics of the laser tube may occur.

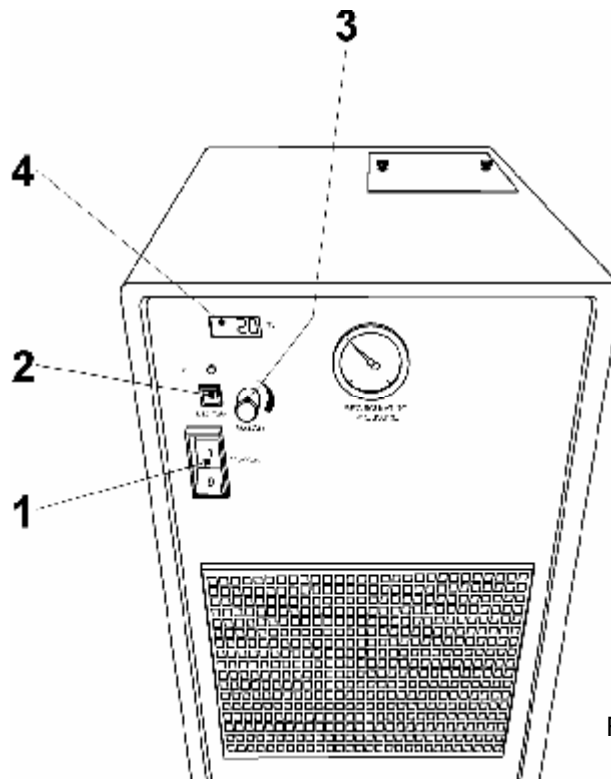

Figure 16



For information on cleaning, maintenance and other information please refer to the Operation Manual of the cooling system.

SECTION 4 – OPERATION

- 4.1 System View / Assemblies and Control Elements
- 4.2 Control Panel
- 4.3 First Steps Before working
- 4.4 First Engraving Tests
- 4.5 Tips and Tricks for Laser Applications

Operation Manual Trotec Professional

4.1 System View / Assemblies and Control Elements

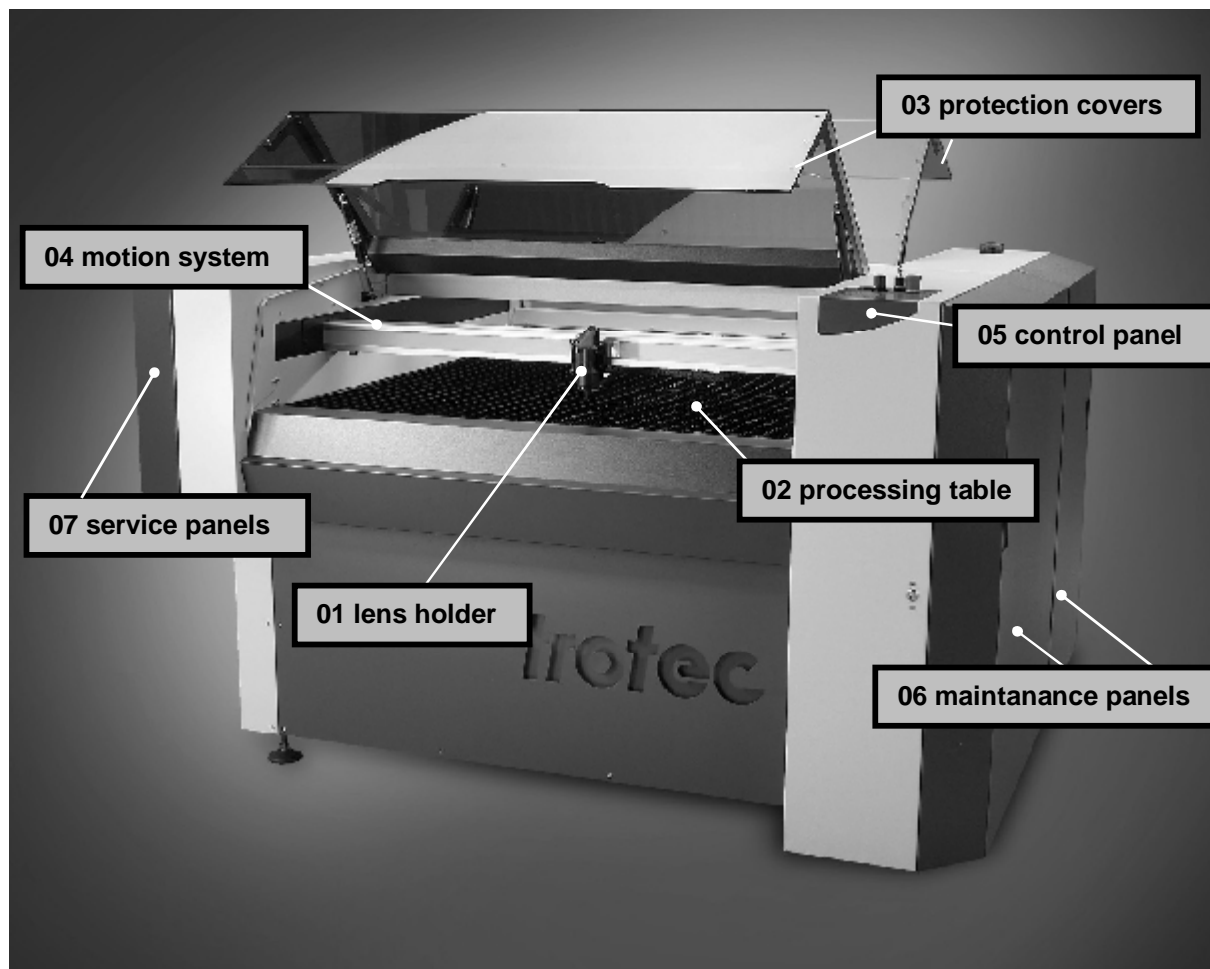

Operation Manual Trotec Professional

4.1 System View / Assemblies and Control Elements

01 Lens Holder



The lens that focuses the laser beam onto the material is mounted inside the lens holder.

02 Processing Table



The workpieces to be cut are put onto the processing table. To facilitate orientation, a horizontal and a vertical stop is located on the table. The horizontal stop is given by wheels which also help you to load bigger workpieces. The vertical stop is a small metal plate, which can be turned to prevent hindrance during unloading workpieces to the back.

03 Protection Covers



If one of the protection covers is opened, no data is processed. After closing the protection cover, the device is not ready to process commands for 5 seconds. If the protection cover is opened during operation, the motion system is stopped. The device switches into "Pause" mode, the "Pause" button lights up. The last processed command is completed.



Please note, that the laser tube is switched off **immediately** and consequently the result is incomplete. During processing of commands the protection cover should only be opened after pressing the "Pause" button.

Operation Manual Trotec Professional

4.1 System View / Assemblies and Control Elements

04 Motion System



The motion system is that part of the machine that performs the mechanical movements in X direction (left-right) and Y direction (forward-back).

05 Control Panel



The Control Panel contains multiple buttons and displays for controlling the device.

06 Maintenance access panels

If a maintenance access panel is opened, no data is processed.



After closing such a panel, the device is not ready to process commands for 5 seconds. If the door is opened during operation, the motion system is stopped. The device switches into "Pause" mode, the "Pause" button lights up. The last processed command is completed.

07 Service access panels

Operation Manual Trotec Professional

4.2 Control Panel

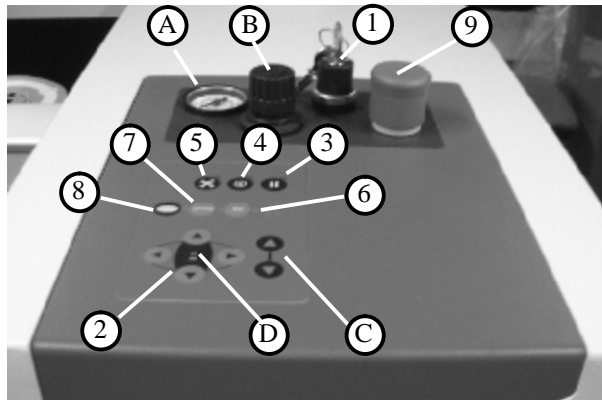

Figure 19

1 Ready Switch

Activates the ON/OFF switch and prevents unauthorized use.

The following conditions must be fulfilled for correct start up:

- unrestricted freedom of motion of the mechanics
- no service plug installed

If the service plug is connected an acoustic signal sounds and the status display (D) flashes fast in green.

Immediately after being switched on, the device starts the referencing process. If the referencing process is completed correctly, an acoustic signal sounds and the device is ready for operation. The readiness for operation is additionally displayed by green (slow) flashing of status display (D).



Before switching on the device, the user must make sure that no objects of any kind are located inside the operating space, which could limit or obstruct the mechanics of the device.



When switching off the mains supply, all processing data is lost.

Operation Manual Trotec Professional

4.2 Control Panel

2 POSITIONING KEYS X/Y

Use the positioning keys to manually move the lens holder into the indicated directions.



When you press two keys simultaneously, the lens holder moves diagonally.

When you press the "Test" keys (6) and one of the positioning keys simultaneously, a movement to the corresponding end position is performed.

The status display of the device (D) is located in the center of the key pad.

3 PAUSE



Used to stop the current working process (key lights up). As soon as the last command has been completely processed, the motion system moves to the upper left – the device is in Pause mode.

If this key is pressed a second time, the key illumination goes out, the interrupted working process is continued.

Operation Manual Trotec Professional

4.2 Control Panel

4 STANDBY



Switches the device into Standby mode (machine ready, waiting for commands) – key lights up.

By pressing the key again the device is switched back to Ready mode.

5 GAS ASSIST



Used to manually switch the gas assist on and off.

Press the "Test" key (6) and the gas assist key together to activate the gas assist.

This key is useful to set the correct gas flow rate before processing. During cutting, the gas assist is controlled by the software.

6+ 7 TEST / SERVICE



The keys "Test" and "Service" pressed simultaneously cause a laser test pulse. This is used for maintenance work and only works with the doors closed while the water chiller is running or with the service plug attached.



As in this case an increased danger of laser radiation exists, an acoustic signal sounds.

8 STATUS INDICATOR LASER BEAM



Indicates, that a laser beam is currently being emitted.

Operation Manual Trotec Professional

4.2 Control Panel

9 EMERGENCY OFF



Use it to disconnect the machine from mains in case of an emergency. To enable the ON/OFF switch again, turn the switch clockwise.

D/8 STATUS DISPLAY (indicates the current status of the device):

green, flashing slowly (0.5 Hz)	D	Professional is ready
green, flashing fast (2 Hz)	D	Cover has been opened
green permanent light / Pause mode	D	Data available in the Professional
red permanent light	8	Laser beam is being emitted
green/red flashing alternately	8 + D	Cover open during switch-on process, simultaneously acoustic signal - no referencing

A/B GAS PRESSURE CONTROL (OPTION)



This is used to control the gas pressure on machines that are equipped with the optional gas kit. By turning B the gas pressure shown in A will change. This will only work correctly while the gas is on (see point 5).

Please note that the manometer will show only a pressure, if an external gas is used. It will not work for compressed air that comes from the internal compressor.

Operation Manual Trotec Professional

4.3 First Steps Before Engraving

To prepare your laser engraver for the first engraving tests, perform the following steps:

1. Move the Ready switch (key switch) in position I
2. Switch the Professional on with the ON / OFF switch.

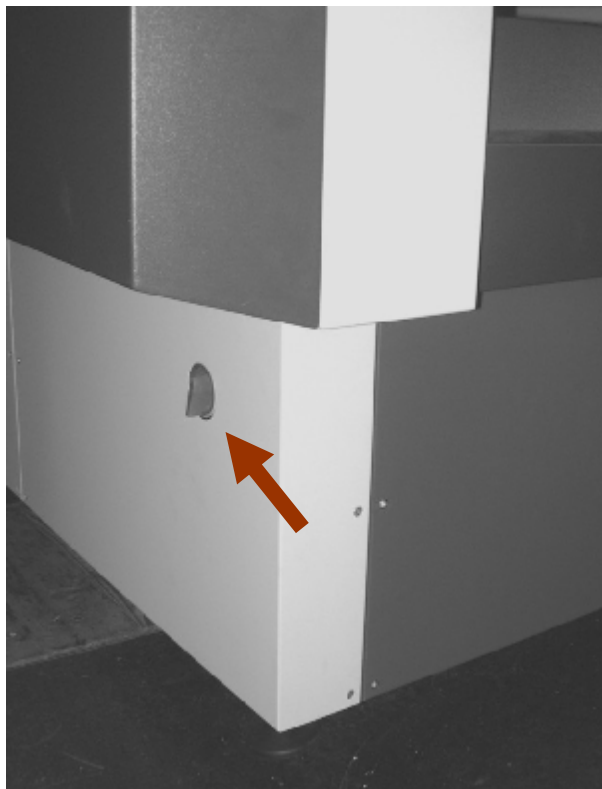

Figure 20: ON-OFF switch

3. The motion system automatically references in X/Y direction.
4. Open the protection cover and place the workpiece on the processing table.

Operation Manual Trotec Professional

4.3 First Steps Before Engraving



Usually you position big workpieces into the upper left-hand corner of the processing table against the horizontal and vertical stops. However, any other position on the processing table is also possible.



Workpieces, that are larger than 1300 x 1300 mm, can be processed provided they can be loaded and the protection cover can still be closed properly. Do not try to manipulate the safety system to install larger workpieces on the system. This could lead to exposure to laser radiation.

4. Focussing the Laser Beam

For the laser beam in your laser system to be able to engrave and cut precisely, the energy is focussed with a lens system, which is mounted on the motion system in a lens holder.



The focussing point of the laser beam is located a certain distance below the lens (depending on the focal length), which is measured using the focussing tool.

For optimal processing the surface of the material that you want to engrave or cut, must be adjusted to this point.

- A1. Move the processing head over the material to be processed by means of the positioning keys X/Y

- A2. Hang the focussing tool on the external ring of the working head so that the focussing tool can move unhindered. Move the laser head downwards by turning the adjustment wheel. While doing this carefully observe the focussing tool.

Operation Manual Trotec Professional

4.3 First Steps Before Engraving



Figure 23

As soon as the tool tilts to the side the lens is focussed onto the surface of the material.

Operation Manual Trotec Professional

4.4 First Engraving Tests

The following steps describe how to successfully engrave a first pattern using the Trotec manager.

(If you use TroCAM, Type3 or a different HPGL code creating software please refer to the instructions of that software packages. In such a case, the code can be transferred directly to the machine, without using the Trotec manager)

Please follow the individual steps:

1. First switch on the computer, then the machine.

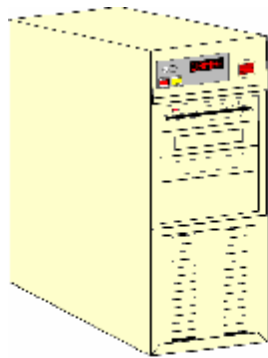

1.

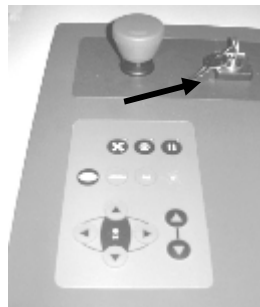

2.

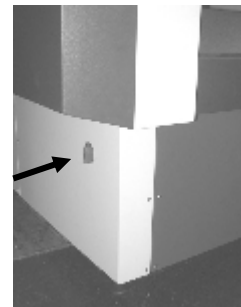

3.

Figure 24

2. Put the object to be processed into the laser and move into the desired position on the processing table. Usually the object is positioned in the upper left-hand corner. Use a ruler to determine the dimensions of the object to be processed.
3. With the positioning keys the engraving head is positioned over the material to be processed. You focus with the help of the focussing tool.

Operation Manual Trotec Professional



Figure 26: setting the focus

Operation Manual Trotec Professional

4.4 First Engraving Tests

4. Generate a graphic with the help of your graphics software. The size of the graphic does not matter as the printer driver adjusts it to the workpiece, automatically if requested.



Pos. 5 – 7 and 12 also see Operation Manual Part B – Software

5. Select "File Print", to access the Printer driver, where you can perform workpiece and material settings as well as specify a job name or a job number.
This file is automatically transferred into the TROTEC Manager.
6. After the engraving material, the engraving direction, the orientation of the workpiece and the orientation of the plate have been specified in the TROTEC Manager under "Plate, Setup Plate", the job can be positioned on the plate with a double-click or drag and drop. If necessary, the job can be positioned at any position on the plate by dragging with the mouse. The position of the job corresponds with the engraving position on the engraving table.
7. Establish a connection with the engraver by clicking on the button "Establish Connection" in the Engraver Control.
8. Switch on the exhaust system.
9. Switch on the cooling system.
10. Finally press the START button (green arrow) in the Engraver Control of the Manager, to start the process.
11. While the laser is working, you can generate the next graphic.
12. When the engraving is complete, the Manager offers you the following possibilities:
 - delete the job
 - Job Reset and placing back in to the waiting list for later repeat of the engraving.
 - Job Reset and immediate repeat

Operation Manual Trotec Professional

4.5 Tips and Tricks for Laser Engraving



The engraving depth can easily be varied through the laser power or the speed. To increase the engraving depth, reduce the speed or increase the power setting. This way you increase the amount of energy per area unit. Engraving too deep, however, reduces the quality of the details. With coated materials the required power depends of the kind and thickness of the coating. With power set too high the individual lines become too thick and a sharp picture cannot be achieved. The resolution of the graphics should usually be at 500 dpi. The dpi setting (number of lines per inch) depends on the requested quality. The lower this setting is, the lower the resolution of the engraved picture will be. The ppi setting defines the amount of laser pulses per inch. A decrease reduces flaming and increases the energy of a pulse, which can improve the overall result (e.g. when engraving some sorts of plastic materials).



Protection foil:

Remove the protection foil only from the engraving area. However, leave the protection foil on the area that is not engraved, to avoid scratching of the material.



Plastics:

Plastics for engraving is available in many different colors and thicknesses and with many different coatings and surfaces. The majority of available plastics can be well engraved and cut with the laser. Plastics with a micro-porous surface seem to give the best result, because less surface material needs to be removed. As most plastic materials have a low melting point, a low ppi setting should be selected to reduce the danger of melting.

Operation Manual Trotec Professional

4.5 Tips and Tricks for Laser Engraving



Acrylic:

There are two different types of acrylic – cast and extruded. The cast acrylic becomes white or mat after engraving, the extruded acrylic remains clear. Use extruded acrylic for engravings that are filled with paint and cast acrylic for normal engravings. Cast acrylic can be best engraved without protection foil. It is better to engrave the entire surface with a low energy setting.



Engraving photographs:

Engraving photographs can be quite a challenge at the beginning. But as soon as you understand the basics it will become easier for you. Scan the desired picture with a resolution of 300 dpi. Adjust brightness and contrast so that lighter colors become lighter and darker colors become darker. The photo might look better if you use a filter, which sharpens the contours. The next step is the selection of a raster. Usually the software offers a selection of different rasters with a specified number of lines per inch and different raster angles. Use a raster with between 20 and 100 lines per inch. Increasing the number of lines per inch decreases the size of the points. Try which raster you think looks best. With one material large points look better, with another material smaller points look better. If you cannot select rasters with your software, the Trotec Printer driver will select the raster automatically.

Operation Manual Trotec Professional

4.6 Tips and Tricks for Laser Cutting



Cut path

If you want to achieve very good results when laser-cutting acrylic or wood, we recommend to place the workpiece so that the laser radiation never gets in contact with the processing table bars. You can achieve that by removing bars of the table. By doing this the smoke and the melting residuals underneath the plate can escape unhindered and no back reflections of the radiation affect the quality of the cut edge.

Generally the protection foil should be removed, especially when there is considerable development of fumes. During laser cutting the Hz setting (pulses per second) should be set low, in particular for flammable materials.



Multiple cutting (insert logo)

Sometimes a clearer contour can be achieved by cutting twice rather than cutting only once. Especially on very heat sensitive materials.

Operation Manual Trotec Professional

4.7 Tips and Tricks for the Production of Rubber Dies



The various mixtures and densities of rubber plates cause a slightly varying engraving depth. The settings in the overview table give a good indication. Since engraving a standard rubber material requires a relatively high laser power, the laser power is principally set to 100% and only the speed is varied.

Due to their lower density, so-called microporous rubber materials allow a significantly higher engraving speed. Test the rubber first, to find out the correct speed setting.

The TROTEC Manager software simplifies the creation of a stamp significantly. Mirroring as well as inverting is performed automatically and a cone-shaped shoulder is generated around each letter. Due to the wider base the letters are stabilized during stamping and therefore the imprint becomes clearer. If you engrave rubber dies without using this option, the letters will have no shoulders making them very thin and unstable.

To avoid flaming, we recommend a very low HZ setting for cutting the rubber die. If the Hz setting is further reduced, the laser pulses are set so far apart from each other that their edges just touch. This results in a perforation. The rubber die stays connected to the rubber plate but can be torn off easily. The advantage of this method is, that there is practically no further risk of deformation or melting of the material. Furthermore, the entire plate can be removed from the laser at one time instead of having to collect all dies individually.

Engraving rubber produces a considerable amount of dust. Therefore a well-dimensioned exhaust system and its regular maintenance are very important.

SECTION 5 – MAINTENANCE

- 5.1 Cleaning the System
- 5.2 Cleaning the Optical Parts
- 5.3 Maintenance Plan

Operation Manual Trotec Professional

5.1 Cleaning the System



Caution – use of controls or adjustments or performance of procedures other than those specified herein may result in hazardous laser radiation exposure.



Before starting cleaning and maintenance work always switch off the device and unplug the mains plug.



You should check **once a day**, whether dust has accumulated in the machine. In case of soiling the machine must be cleaned.

The cleaning interval strongly depends on the material that is being processed and the operating time of the device. Please bear in mind that only a clean machine guarantees optimal performance and reduces the service costs.

General Cleaning:

1. Make sure, that the device is switched off. Open the acrylic top doors.
2. Thoroughly remove all loose dirt particles and deposits in the interior of the machine especially from the head.
3. You can clean the acrylic top doors with a cotton cloth. Do not use paper towels as they could scratch the acrylic.

Operation Manual Trotec Professional

5.2 Cleaning the Optical Parts

The lens has a durable multi-coating and cannot be damaged by correct and careful cleaning. You should inspect the mirrors and the lens at least once a week. If you discover a veil of haze or dirt, you must clean them.

Follow the instructions below for the cleaning of optical parts:

CLEANING THE LENS

1. Put a piece of cardboard or a similar flat material on a place on the engraving area which is easy to reach.
2. Move the working head into the center of this object and move the lens holder all the way down.
3. Now you can remove the lens carriage by removing the 6mm hose and taking out the two allen screws left and right beside of the head.

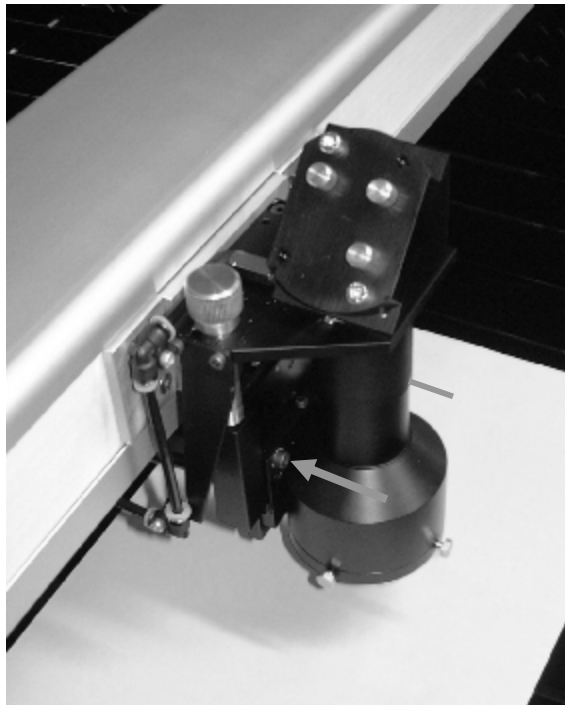

Figure 32: Fixing screws

Operation Manual Trotec Professional

4. Once positioned over a clean lens cleaning tissue, remove the lens from the lens carriage by carefully turning the lens fixing ring and letting the lens and the O-ring drop onto the cleaning cloth.
5. Examine the O-ring and clean it, if necessary, with a cotton bud and lens cleaning tissue.

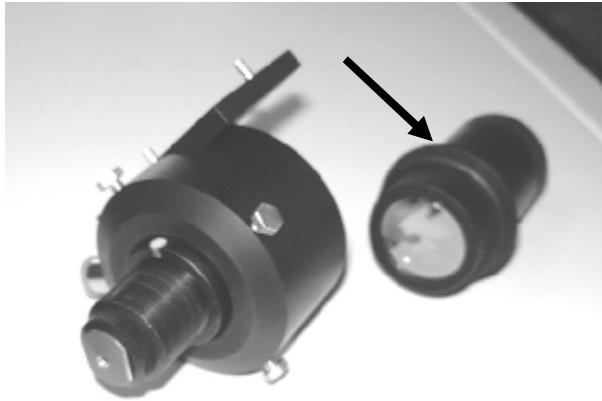

Figure: lens carriage

6. Remove the coarse dust by blowing air onto the lens surface.
7. Hold the lens by its edge with a lens cleaning tissue and use a drop of lens cleaning liquid from the little bottle which you received as an accessory delivered with the laser. While holding the lens on an angle, flush both surfaces of the lens, to wash away coarse soiling.
8. Put the lens on a lens cleaning tissue. Put some lens cleaning liquid on one side of the lens. Leave the liquid to take effect for approximately one minute and then gently wipe it away with lens cleaning tissues soaked with lens cleaning liquid.
9. Finally, dry this side of the lens with dry lens cleaning tissues and repeat the cleaning process on the other side of the lens.



Never use a cleaning tissue twice. Dust accumulated in the cleaning tissue could scratch the lens surface.

10. Examine the lens. If it is still soiled, repeat the cleaning process until the lens is clean.
11. Carefully insert the lens into the lens carriage.

Operation Manual Trotec Professional



Ensure, that the rounded side (= convex) of the lens is facing upwards. Then put the O-ring on top of the lens.

12. Carefully screw the lens carriage back to the working head.

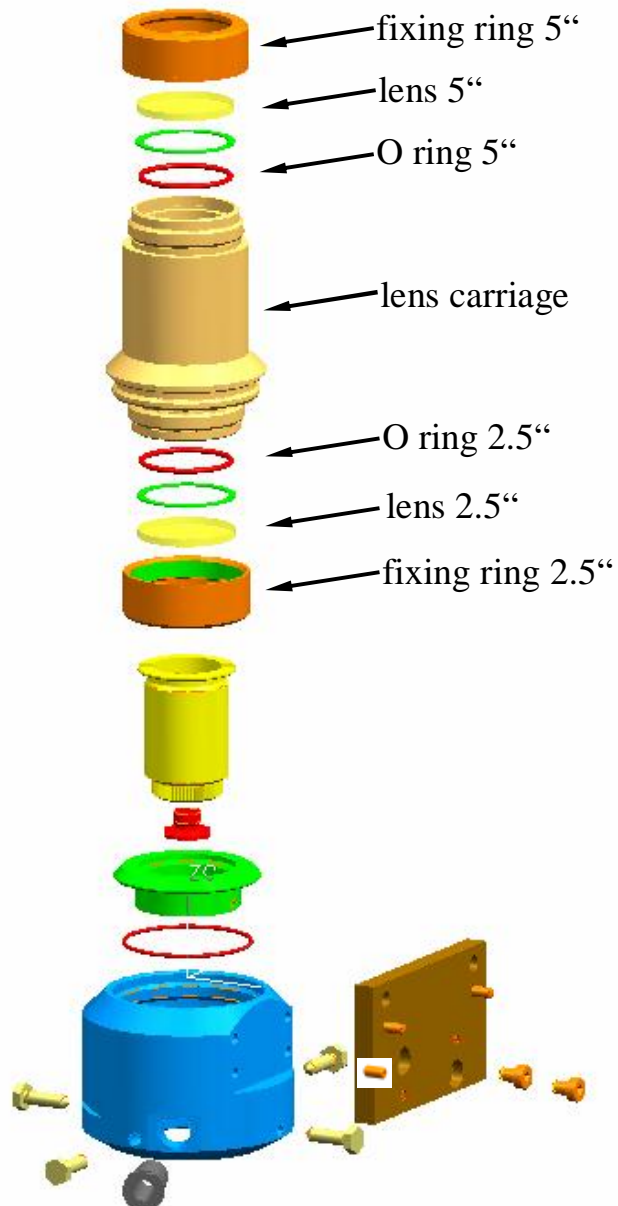

Operation Manual Trotec Professional

5.2 Cleaning the Optical Parts

CLEANING THE MIRRORS #1 THROUGH #3

All optical components on the Professional are in an atmosphere of small overpressure so that dust is prevented from getting in contact with these components. That's also the reason why the cleaning intervals for the first three mirrors are very big.

MIRROR #3

1. The mirror #3 is located on the right side of the machine. To be able to access mirror #3, you must open the maintenance panel.
2. The mirror #3 is attached by means of two allen screws (F), which are located on the mirror holder. Open the screws and remove the lensholder together with the mirror.



Make sure that you do not touch the mirror surface with your fingers as this reduces the mirror's working life significantly.

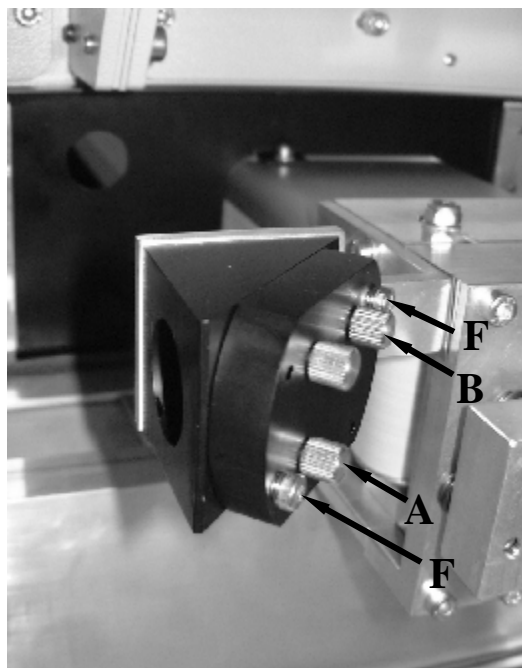

Figure: mirror #3

Operation Manual Trotec Professional

5.2 Cleaning the Optical Parts

3. Use a drop of lens cleaning liquid from the accessories box and, while holding the mirror on an angle, flush the surface of the mirror, to wash away coarse soiling.
4. Put the mirror on a working surface. Put some drops of lens cleaning liquid on the mirror and leave the liquid take effect for approximately 1 minute.
5. Use a folded piece of lens cleaning tissue soaked with lens cleaning liquid and wipe gently over the mirror only once. Use a fresh lens cleaning tissue soaked with lens cleaning liquid each time and again wipe over the mirror only once. Then wipe the mirror dry with a new dry lens cleaning tissue. Never use a cleaning tissue twice, as it could carry dust particles, which can scratch the mirror surface.
6. Examine the mirror and repeat the cleaning process, if necessary.

MIRROR #1 and #2

The mirrors#1 and 2 are to be cleaned in the same way as mirror#3. They are also located behind the maintenance access panel.

Mirror #2



Mirror #1

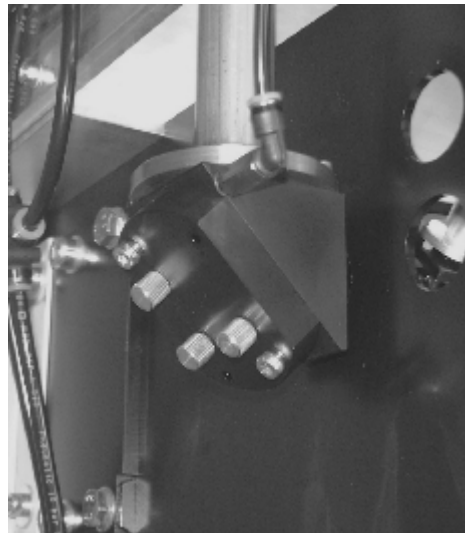

Operation Manual Trotec Professional

5.2 Cleaning the Optical Parts

MIRROR #4

1. Mirror#4 is located directly above the lens on the engraving head of your laser engraver. It should be inspected once a day and cleaned if necessary.
2. Loosen the fixing screws (1) and lift the mirror from the mirror holder.



Pay attention that the mirror doesn't grind over the mirror holder, as it can be scratched very easily.



Figure 34: mirror #4 fixing screws

Operation Manual Trotec Professional

5.2 Cleaning the Optical Parts

3. Use a drop of lens cleaning liquid from the accessories box and, while holding the mirror on an angle, flush the surface of the mirror, to wash away coarse soiling.
4. Put the mirror on a working surface. Put some drops of lens cleaning liquid on the mirror and leave the liquid to take effect for approximately 1 minute.
5. Use a folded piece of lens cleaning tissue soaked with lens cleaning liquid and wipe gently over the mirror only once. Use a fresh lens cleaning tissue soaked with lens cleaning liquid each time and again wipe over the mirror only once. Then wipe the mirror dry with a new dry lens cleaning tissue. Never use a cleaning tissue twice, as it could carry dust particles, that can scratch the mirror surface.
6. Examine the mirror and repeat the cleaning process, if necessary.
7. Re-insert the mirror into the mirror holder by setting it straight onto the holder and tightening the screw.



Don't move the brass adjustment screws. These define the mirror angle. A realignment is only necessary when optical components are changed

Operation Manual Trotec Professional

5.3 Maintenance Plan

	daily	weekly	monthly	yearly
Laser				
Lens, mirror #4 <input type="checkbox"/>	Check Cleaning if required	<input type="checkbox"/>	<input type="checkbox"/>	<input type="checkbox"/>
mirrors #1...3		Check Cleaning if required		
Processing table and rulers <input type="checkbox"/>	Cleaning			
Entire working area – general cleaning <input type="checkbox"/>			Cleaning	
Exhaust System				
Bag filter	According to the operation manual of the exhaust system			
Filter mat				
Particle filter				
Activated carbon filter <input type="checkbox"/>				
Cooling System				
Pump filter <input type="checkbox"/>			Cleaning	
Condenser heater <input type="checkbox"/>			Cleaning	<input type="checkbox"/>
Cooling agent		Examination		Replace- ment
Pump				Lubricate

For detailed information on the maintenance activities on exhaust and cooling systems please refer to the respective manuals.

SECTION 6 – ADDITIONAL INFORMATION

- 6.1 Tips for Troubleshooting
- 6.2 Requirements for the Serial Cable
- 6.3 Connector Assignment
- 6.4 Training Program
- 6.5 Support Sheet

Operation Manual Trotec Professional

6.1 Tips for Troubleshooting

- | Professional does not react after activating the "ON" key.
 - Check the mains connection.
 - Check the main fuses of the machine. Replace defect fuses with fuses of the same type and value.

- | No movement is performed after sending data to the Professional:
The frequency of the Power/ON LED is increased.
 - Check whether the doors of the Professional are tightly fastened and the water chiller is working.

- | The following error message is displayed when trying to establish a connection between the Manager and Professional:
"Could not build up connection to the laser engraver."
 - Check the cable connection between computer and machine.
 - Make sure that you are actually using the correct serial interface COM1 or COM2 of your computer and that it is functional.
 - Check the interface selection in "Options" in the "Settings" menu of the Manager.

- | A job, which was created with the graphics software, does not appear in the waiting list of the Manager.
 - Check whether the sorting function "Kind" and "Resolution" are activated in the waiting list.
 - Make sure that the directories "Archiv", "Spool" and "Work" have been created in the directory of the Manager ("TROTEC") and that the correct paths to these directories have been set under "Options" in the "Settings" menu.

- | A job transferred to the Manager does not contain any graphics,
 - Use the "Fit to page" option in the printer menu of your graphics software.

Operation Manual Trotec Professional

6.2 Requirements for the Serial Cable

The following drawing describes the pin assignment for the serial cable:

for PCs

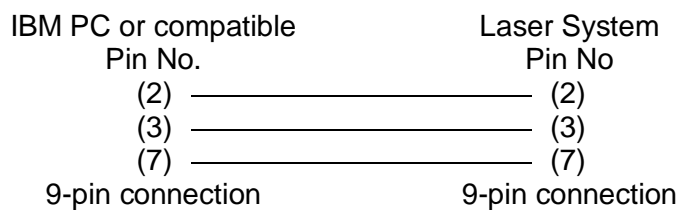

Operation Manual Trotec Professional

6.3 Connector Assignment

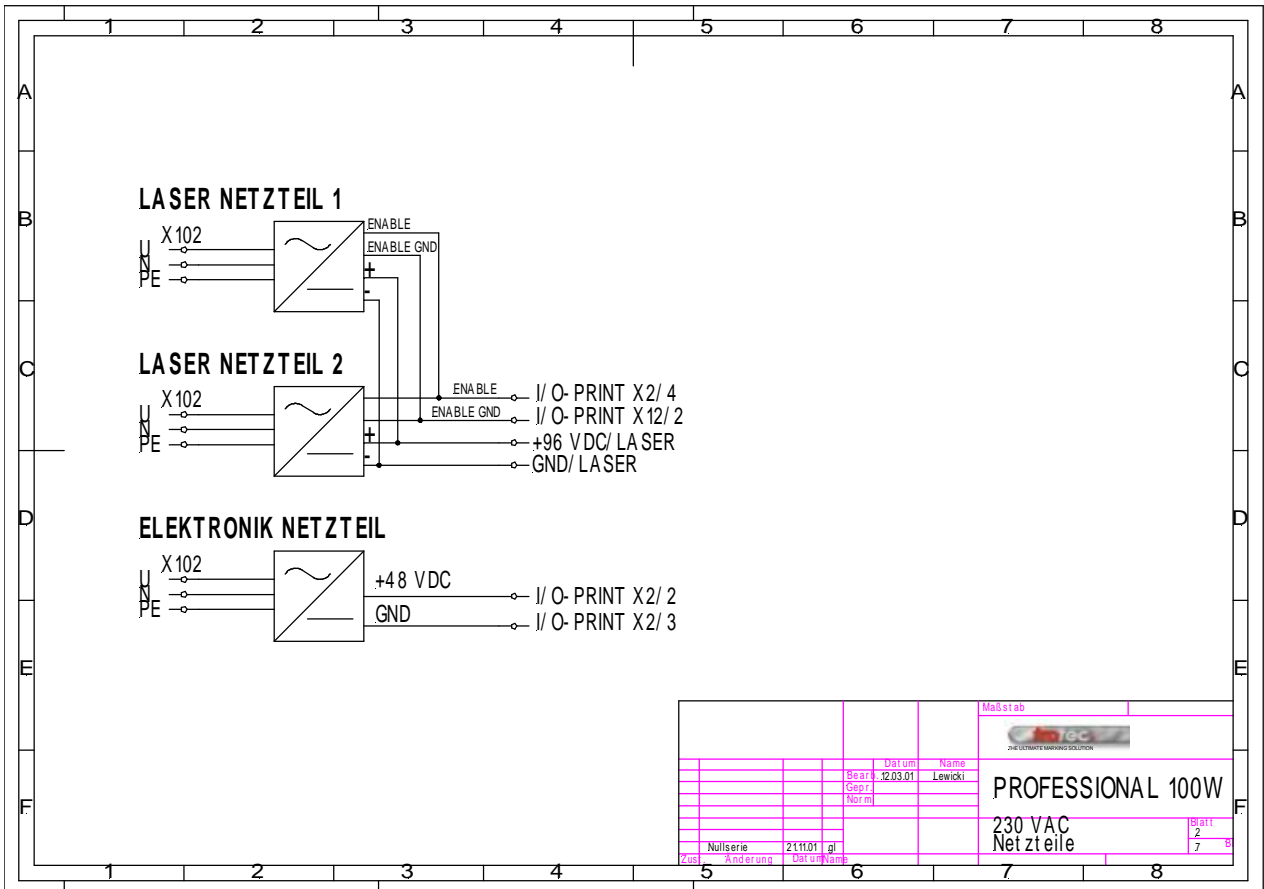

Operation Manual Trotec Professional

6.3 Connector Assignment

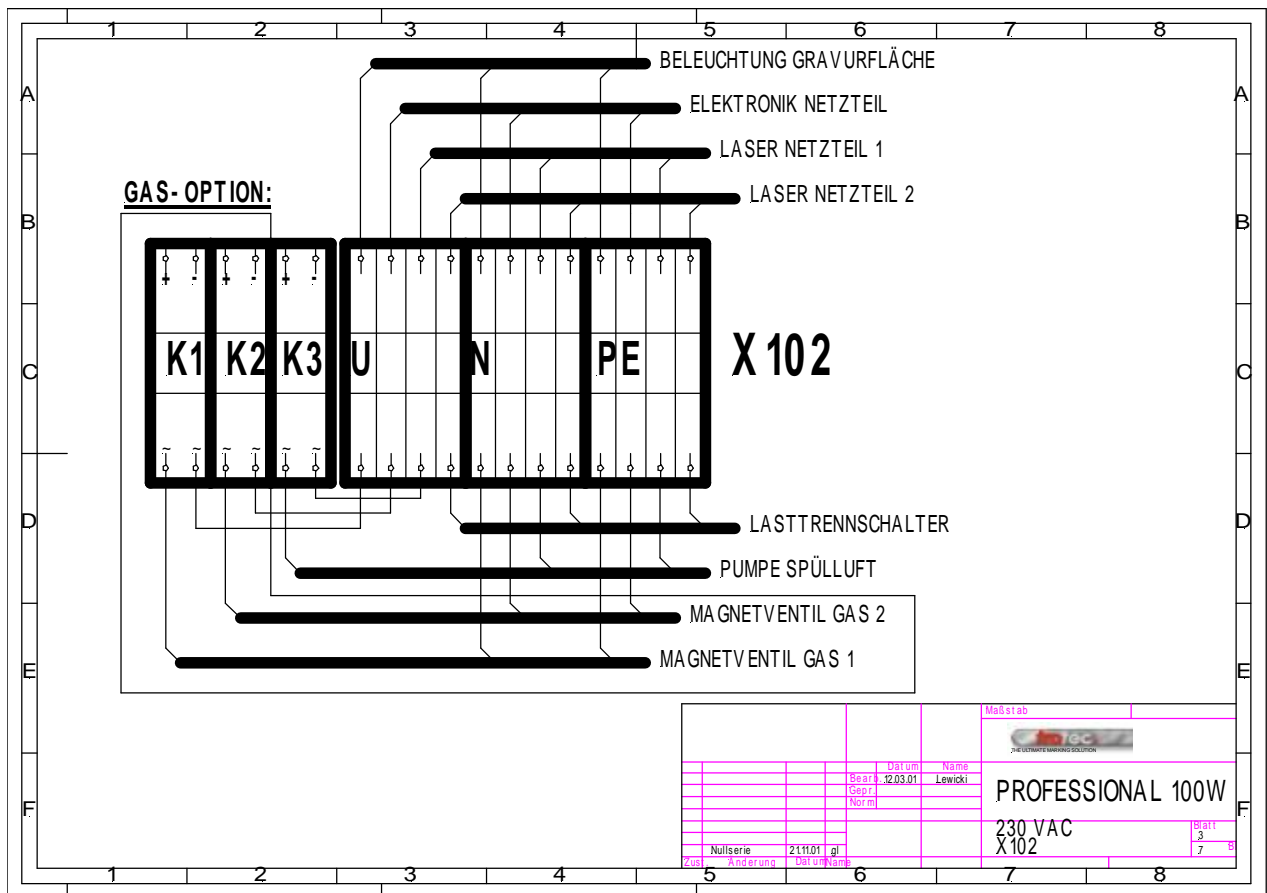

Operation Manual Trotec Professional

6.3 Connector Assignment

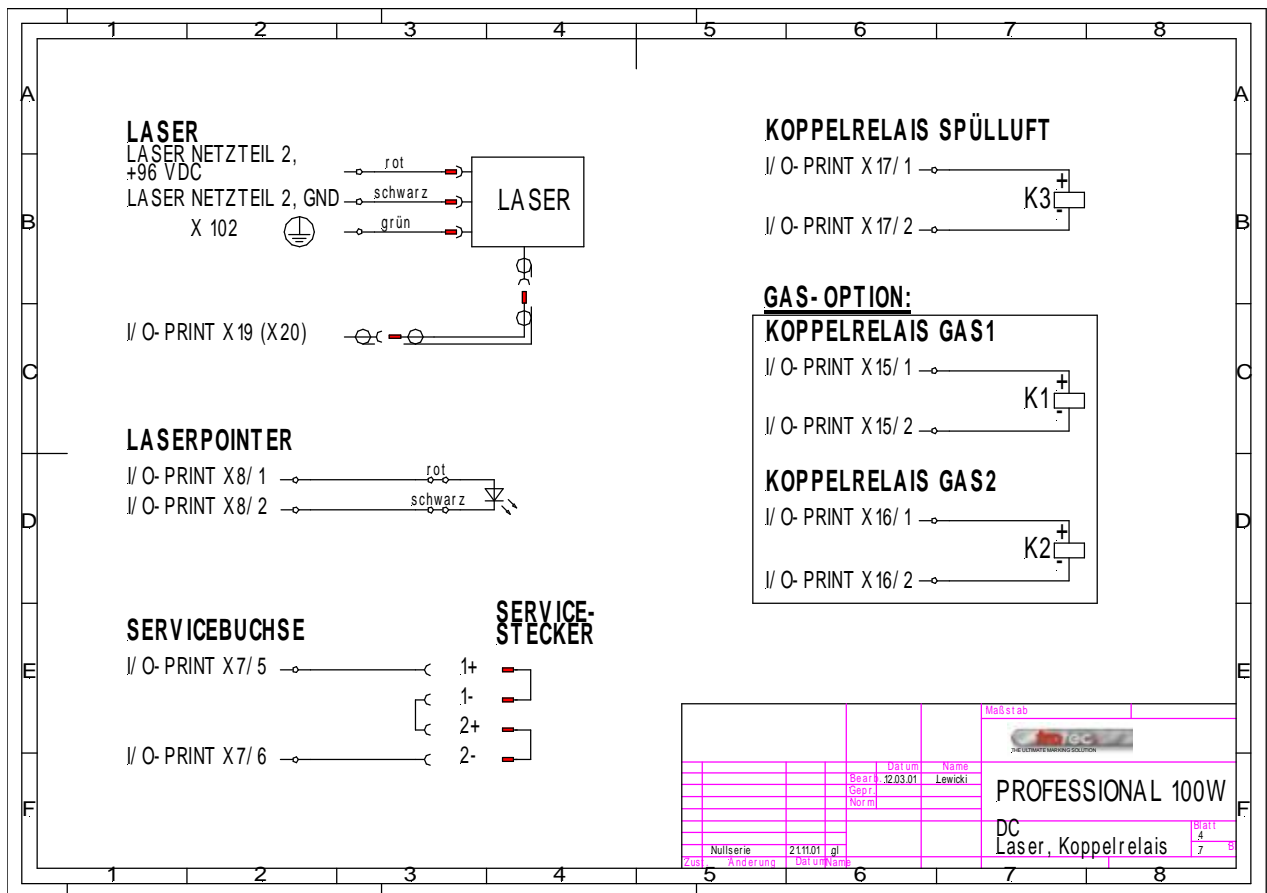

Operation Manual Trotec Professional

6.3 Connector Assignment

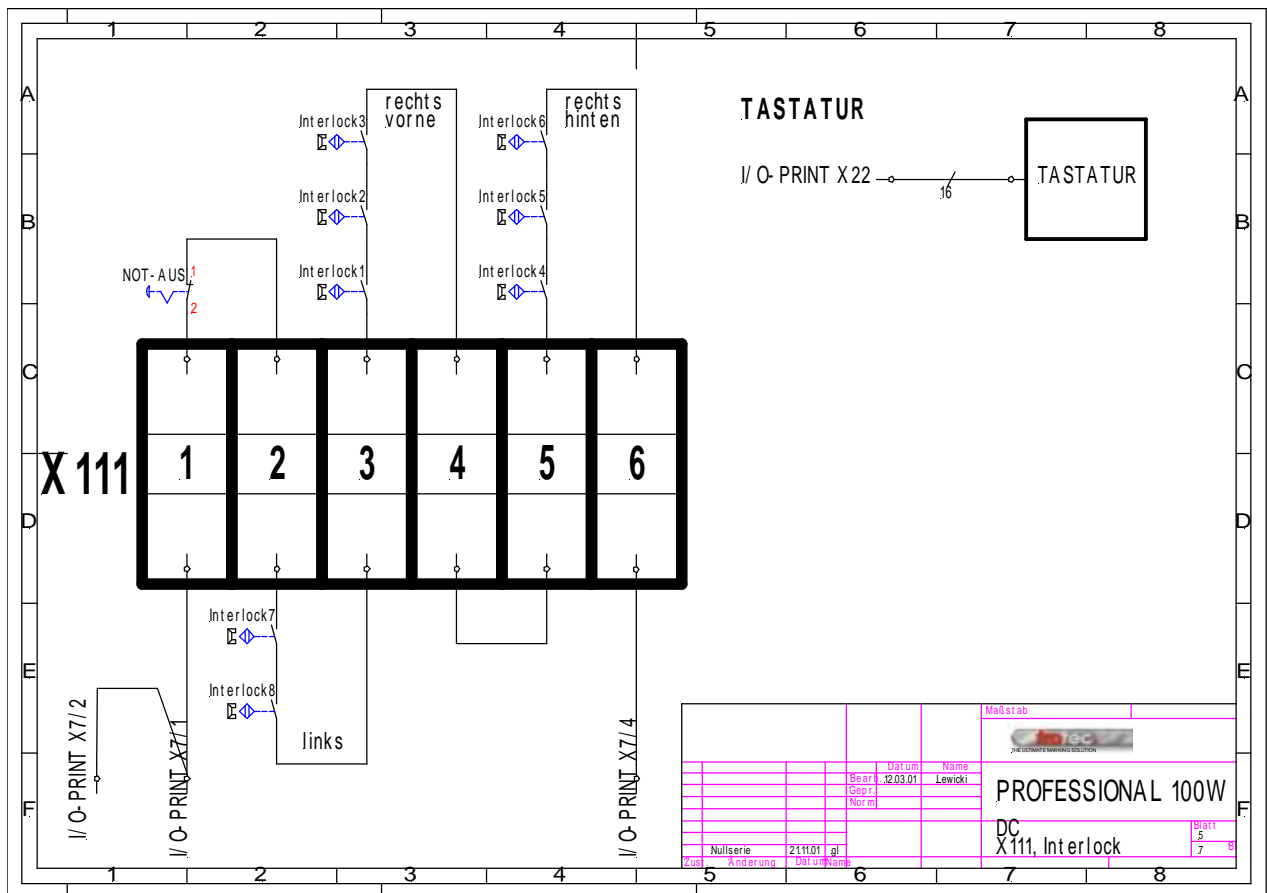

Operation Manual Trotec Professional

6.3 Connector Assignment

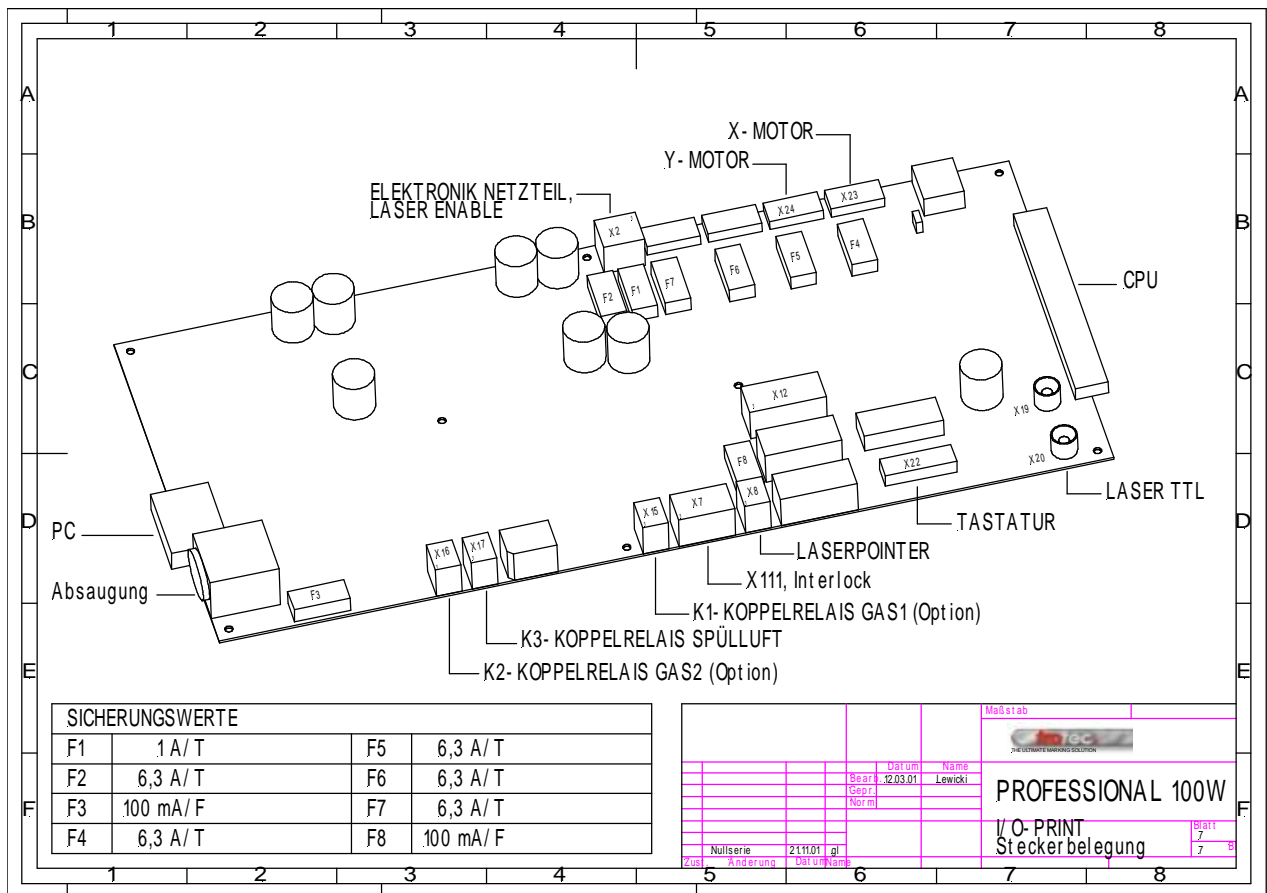

SECTION 7 – INDEX

7.1 Index

Cleaning the Optical Parts	53
Cleaning the System	52
Computer – Requirements	25
Connecting the Computer	27
Connecting the Cooling System	30
Connecting the Exhaust System	28
Connecting the Professional	26
Connector Assignment	64
Contents of Delivery	23
Control Panel	37
Cooling System – Requirements	25
Designated Use	5
EU Conformity Declaration	8
Exhaust System - Requirements	25
First Engraving Tests	44
First Steps Before Engraving	41
General Information for Using the Operation Manual	4

Operation Manual Trotec Professional

7.1 Index

Index	73
Laser Safety Information	13
Location	24
Mains Connection	26
Maintenance Plan	60
Manufacturer's Label	7
Safety Precautions When Operating the Device	14
Serial Cable – Requirements	63
Support Sheet	71
System View / Assemblies and Control Elements	34
Table of Contents	1
Technical Data/ Device Specification	6
Tips and Tricks for Laser Cutting	44
Tips and Tricks for Laser Engraving	47
Tips and Tricks for the Production of Rubber Dies	50
Tips for Troubleshooting	62
Unpacking the Professional	20
Warning and Information Labels	16
Warranty Regulations	9

Operation Manual Trotec Professional

Operation Manual Trotec Professional

Options

1. Gas kit

The gas kit is used to select between different processing gases and to define the gas flow rate directly at the Professional. Therefore we have a pressure control valve and two external gas supply inlets on the machine. The gas can be selected in the postprocessor to make sure the appropriate gas is used.

2. Vacuum table

The vacuum table is used to make sure that thin workpieces are lying flat on the table. Thin workpieces often are bent because of the inner material tension. Another advantage is that the vapours are sucked to the bottom and so there will be no problem with material condensation on the surface.

The vacuum table is a honeycomb construction where not used parts of the processing area must be covered (e.g. you can use thin plastics).